



Chipsmall Limited consists of a professional team with an average of over 10 year of expertise in the distribution of electronic components. Based in Hongkong, we have already established firm and mutual-benefit business relationships with customers from,Europe,America and south Asia,supplying obsolete and hard-to-find components to meet their specific needs.

With the principle of “Quality Parts,Customers Priority,Honest Operation,and Considerate Service”,our business mainly focus on the distribution of electronic components. Line cards we deal with include Microchip,ALPS,ROHM,Xilinx,Pulse,ON,Everlight and Freescale. Main products comprise IC,Modules,Potentiometer,IC Socket,Relay,Connector.Our parts cover such applications as commercial,industrial, and automotives areas.

We are looking forward to setting up business relationship with you and hope to provide you with the best service and solution. Let us make a better world for our industry!



Contact us

Tel: +86-755-8981 8866 Fax: +86-755-8427 6832

Email & Skype: info@chipsmall.com Web: www.chipsmall.com

Address: A1208, Overseas Decoration Building, #122 Zhenhua RD., Futian, Shenzhen, China





Air Powered Crimp Tool Head
Operating Instruction Sheet and Specifications
Part No. 64005-4100
Eng. No. AT FIFG
(Replaces 19283-0056)

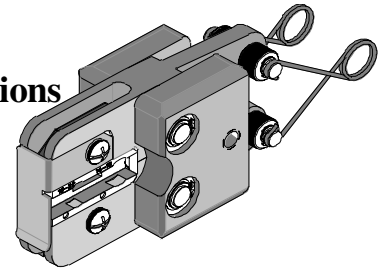

FEATURES

- Quick-change tool head for the 19279-0001 (AT-200)
- Tooling kit is interchangeable with other kits in the 64001 and 64003 Series
- A precision user-friendly terminal locator wire stop holds terminals in the proper crimping position
- Pneumatic powered crimp tools help reduce fatigue and discomfort from repetitive manual crimping

SCOPE

Fully Insulated Flag Quick Disconnects (Standard Flare) Terminals 14-22 AWG. This tool head is intended for use in the 19279-0001 (AT-200) either hand held or with optional bench adapter 19078-0307 (ATBA) and foot switch.

Testing

Mechanical

The tensile test, or pull test, is a means of evaluating the mechanical properties of the crimped connections. The following charts show the UL specifications for various wire sizes. The tensile strength is shown in pounds and indicates the minimum acceptable force to break or separate the terminal from the conductor.

Wire Size (AWG)	*UL 310
22	8
20	13
18	20
16	30
14	50

*UL – 310 – Quick Disconnects, Flags and Couplers

The following is a partial list of the product part numbers and their specifications that this tool is designed to run. We will be adding to this list and an up to date copy is available on www.molex.com.

Wire Size: 18 – 22 AWG 0.80 – 0.35 mm ²						Wire Size: 14 – 16 AWG 2.00 – 1.30 mm ²					
Terminal No.	Terminal Eng No. (REF)	Wire Strip Length		Insul. Dia. Max.		Terminal No.	Terminal Eng No. (REF)	Wire Strip Length		Insul. Dia. Max.	
		In.	mm	In.	mm			In.	mm	In.	mm
19007-0001	AA-2220	.344	8.73	.176	4.47	19007-0021	BB-2221	.313	7.94	.200	5.0
19007-0005	AA-2220X	.344	8.73	.240	6.10	19007-0025	BB-2221X	.313	7.94	.265	6.7
19007-0009	AA-2222	.344	8.73	.176	4.47	19007-0029	BB-2224	.313	7.94	.200	5.0
19007-0011	AA-2222X	.344	8.73	.240	6.10	19007-0031	BB-2224X	.313	7.94	.265	6.7
19007-0015	AA-2223	.344	8.73	.176	4.47	19007-0035	BB-2225	.313	7.94	.200	5.0
19007-0017	AA-2223X	.344	8.73	.240	6.10	19007-0037	BB-2225X	.313	7.94	.265	6.7

Operation

Refer to the instruction manual for the 19279-0001 (AT-200) for mounting this crimp tool head.

Crimping Terminals

1. Place the flag terminal barrel into the conductor anvil of the lower jaw. Make sure the closed end of the barrel is touching the locator. (See Figure 1).

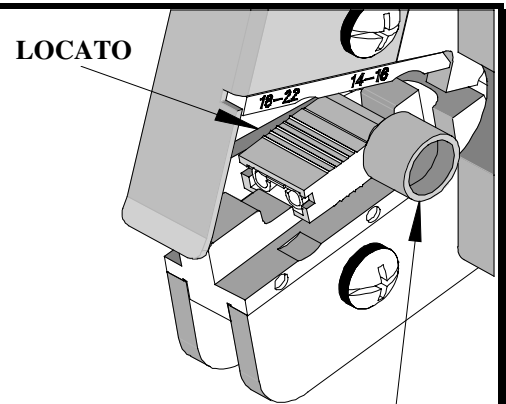

Figure 1 TERMINA

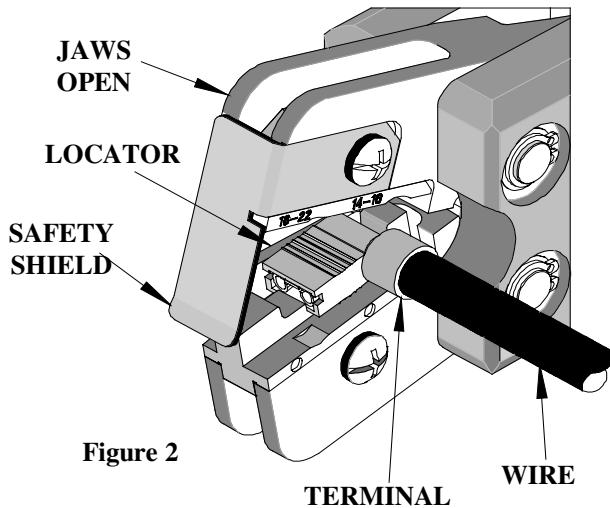

Figure 2

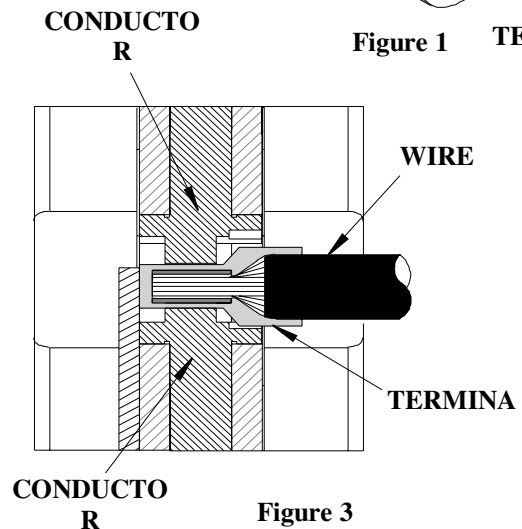

Figure 3

Caution: Never operate this tool without the supplied safety shield in place. Never place fingers in the tool nests.

2. Insert the properly stripped wire into the terminal barrel, (See figure 3).
3. Push on the wire to assure it is fully seated in the terminal (See Figure 2 and 3). Cycle the tool.
4. Remove the crimped terminal. Inspect for proper crimp.

Maintenance

It is recommended that each operator of the tool be made aware of, and responsible for, the following maintenance steps:

1. Remove dust, moisture and other contaminants with a clean brush, or soft, lint-free cloth.
2. Do not use any abrasive materials that could damage the tool.
3. Make certain all pins; pivot points and bearing surfaces are protected with a thin coat of high quality machine oil. Do not oil excessively. The 64005-4100 (AT-FIFG) was engineered for durability, but like any fine piece of equipment it needs cleaning and lubrication for a maximum service life of trouble-free crimping. A light oil, such as 30 weight automotive oil used at the oil points shown in Figure 4, every 5,000 crimps or monthly will significantly enhance the tool life and ensure a stable calibration.
4. When tool is not in use store the tool in a clean, dry area.

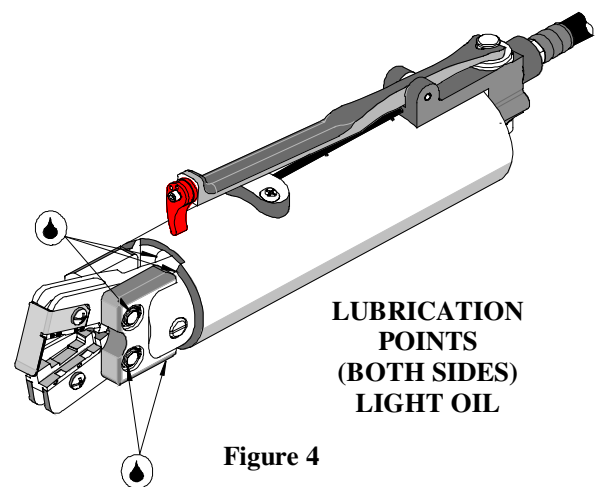
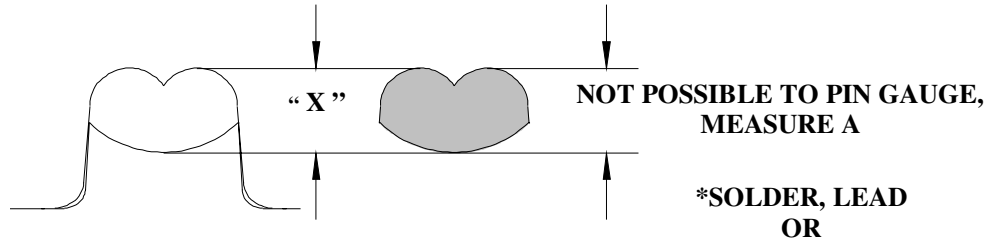

Figure 4

Tool Calibration

A Certificate of Calibration (see last page) was supplied with the tool. To recalibrate this tool, measurements should be taken from each conductor nest and compared to this chart. The tool should be lubricated prior to recalibration to ensure consistent measurements.



Nest Color Code	Wire Range		“X” Dimension Conductor Crimp			Crimp Inspection Marking
	AWG	mm ²	Mean	Go	No Go	
Blue	14 - 16	2.00 – 1.30	.078	.076	.088	---
Red	18 - 22	0.80 – 0.35	.068	.066	.070	---

Warranty

This tool is for electrical terminal crimping purposes only. This tool is made of the best quality materials. All vital components are long life tested. All tools are warranted to be free of manufacturing defects for a period of 30 days. Should such a defect occur, we would repair or exchange the tool free of charge. This repair or exchange will not be applicable to altered, misused or damaged tools.

PARTS LIST

Item	Order No	Description	Quantity
	64005-4100	Crimp Tool Head	(Fig. 5)
1	64005-0000	Basic Air Tool Head	1
2	64001-4175	Locator Assembly	1
3	64001-4170	Tooling Kit	1
Tooling Kit Only			
4	64001-4102	Conductor Punch	1
5	64001-4101	Conductor Anvil	1

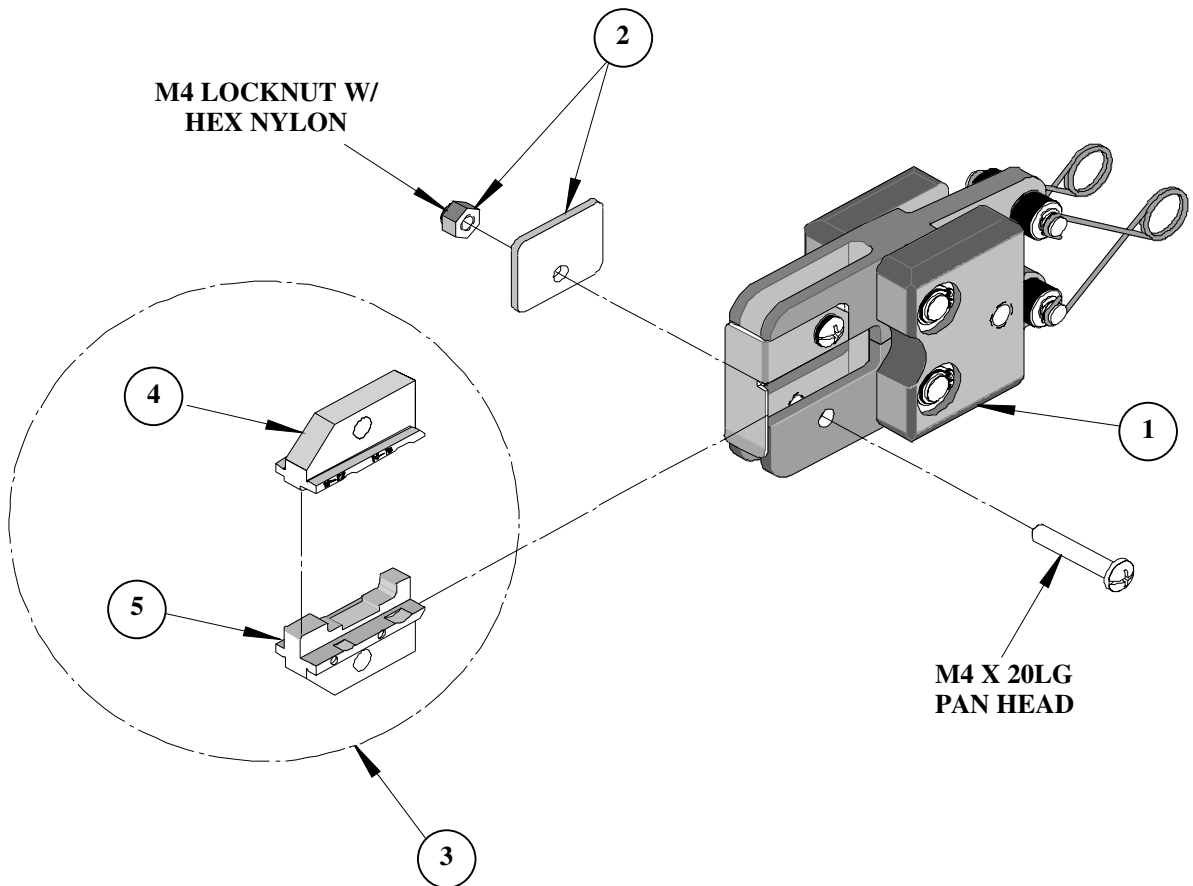

Figure 5

Parts List (Continued)

Item	Order No.	Description	Quantity
	64005-0000	Basic Air Tool Head	(Fig. 6)
1	64005-0103	Nose Guard	1
2	64000-0077	Repair Kit (Springs, Rods Pivots, Rings, and Washers)	1
3	N/A	M4 by 12LG. Freedrive Pan Head Screw	1**
4	N/A	M4 by 30LG. Freedrive Pan Head Screw	1**
5	N/A	3/16" by 3/8" Long Dowel Pin	1**

** The following purchased parts are available from an Industrial supply company such as MSC (1-800-645-7270).

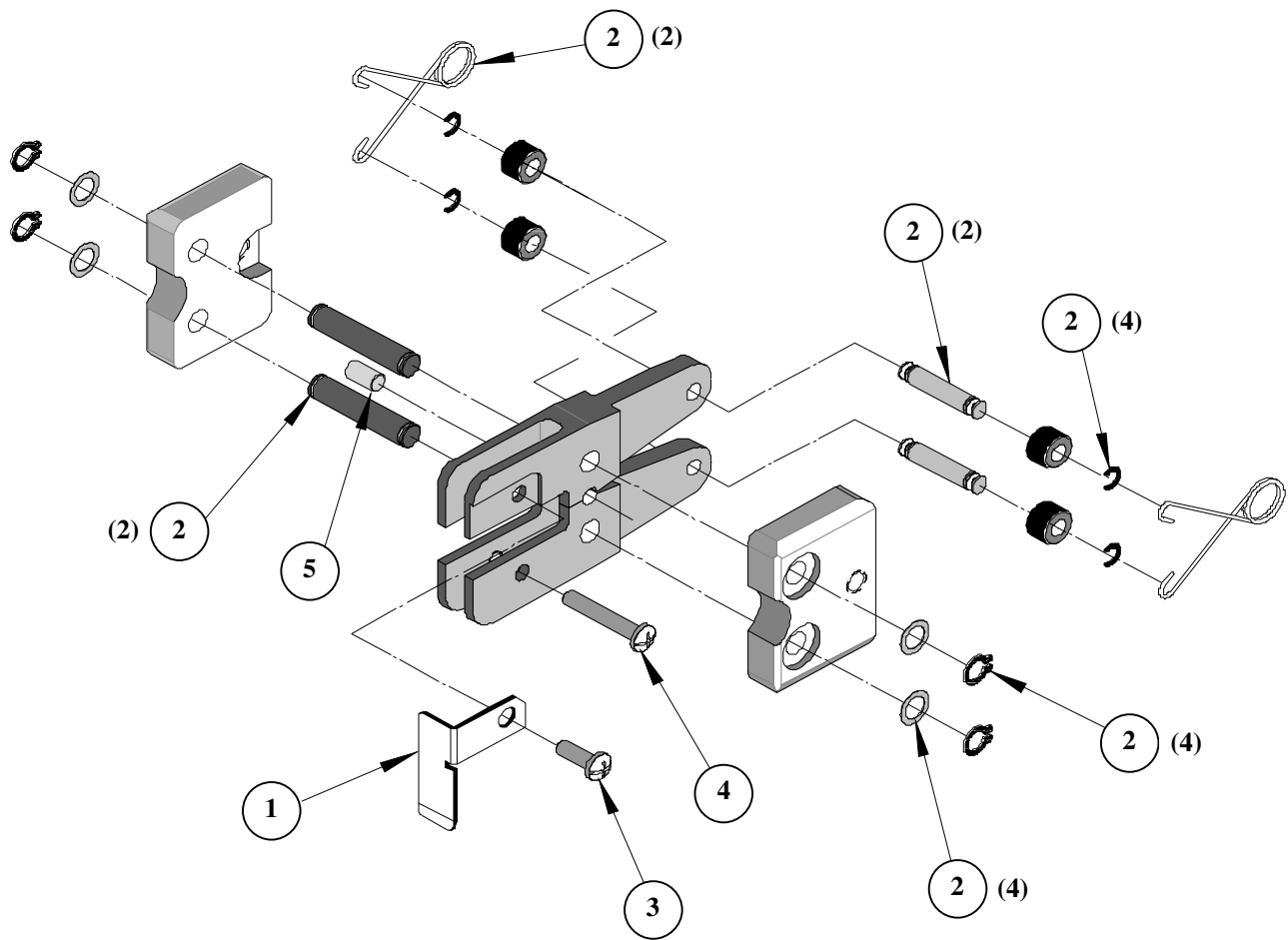
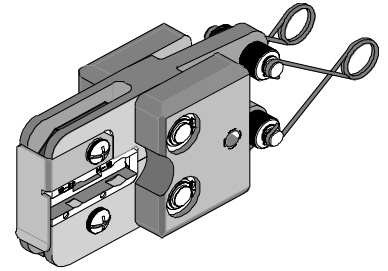

Figure 6



Certificate of Calibration

Tool Order Number -----

Tool Eng. Number -----

Tool Revision -----

Serial Number -----

Date of Manufacture -----

Pin Gauge of Conductor Nest/Nests or Slug height if the nest is the "F" Crimp style.

Range Conductor Nest # 1 = ----- Actual = -----

Range Conductor Nest # 2 = ----- Actual = -----

Technician -----

Date of Calibration -----

Calibration should be done every 5,000 cycles or 3 months.
Tools should be lubricated during this operation.

Molex Application Tooling Group

1150 E. Diehl Road
Naperville, IL 60563
Tel: (630) 969-4550
Fax: (630) 505-0049