



Chipsmall Limited consists of a professional team with an average of over 10 year of expertise in the distribution of electronic components. Based in Hongkong, we have already established firm and mutual-benefit business relationships with customers from,Europe,America and south Asia,supplying obsolete and hard-to-find components to meet their specific needs.

With the principle of “Quality Parts,Customers Priority,Honest Operation,and Considerate Service”,our business mainly focus on the distribution of electronic components. Line cards we deal with include Microchip,ALPS,ROHM,Xilinx,Pulse,ON,Everlight and Freescale. Main products comprise IC,Modules,Potentiometer,IC Socket,Relay,Connector.Our parts cover such applications as commercial,industrial, and automotives areas.

We are looking forward to setting up business relationship with you and hope to provide you with the best service and solution. Let us make a better world for our industry!



Contact us

Tel: +86-755-8981 8866 Fax: +86-755-8427 6832

Email & Skype: info@chipsmall.com Web: www.chipsmall.com

Address: A1208, Overseas Decoration Building, #122 Zhenhua RD., Futian, Shenzhen, China



E

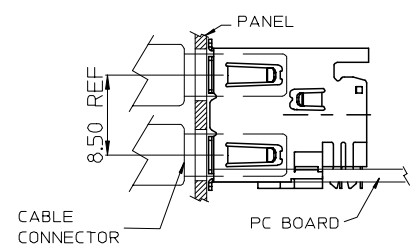
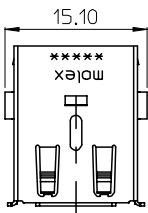

RECESSED MOUNTING CONFIGURATION

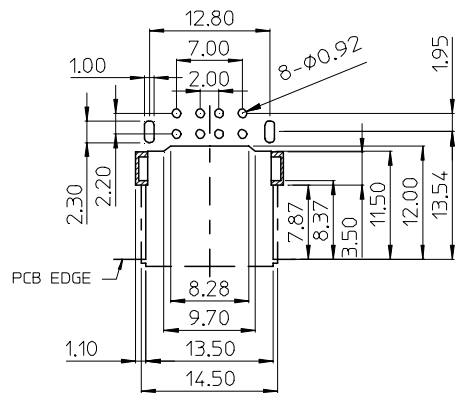

RECOMMENDED PCB LAYOUT COMPONENT SIDE VIEW

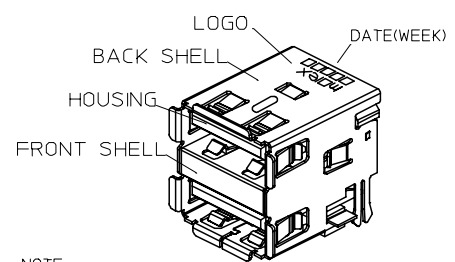

NOTE:

1. MATERIAL:
HOUSING: NYLON GLASS-FIBER REINFORCED, UL94-V0, COLOR: BLACK.
TERMINAL: PHOSPHOR BRONZE.
METAL SHELL: FRONT SHELL: SUS 304
BACK SHELL: BRASS
2. PLATING:
TERMINAL:
CONTACT AREA: SEE TABLE
SOLDER TAIL: TIN PLATED (Sn) ALLOY, THICKNESS=75 MICROINCH MIN.
UNDERPLATE: NICKEL (Ni), THICKNESS=50 MICROINCH MIN.
SURFACE APPEARANCE: BRIGHT.
METAL SHELL:
TIN PLATED (Sn) AT SOLDER AREA
THICKNESS=100 MICROINCH MINIMUM.
UNDER PLATE: NICKEL (Ni), (SOLDERING AVAILABLE)
THICKNESS=50 MICROINCH MINIMUM.
SURFACE APPEARANCE: BRIGHT.
3. RECOMMENDED PCB THICKNESS: 1.20±0.05MM
4. PRODUCT SPECIFICATION: REFER TO PS-67998-002
5. TEST SUMMARY: REFER TO TS-67298-007
6. PACKAGING SPECIFICATION:
REFER TO PK-67298-003 FOR TRAY.
REFER TO PK-67298-004 FOR TAPE & REEL.
7. LEAD FREE AND ROHS COMPLIANCE PRODUCT
8. FOR IR REFLOW PROCESS
9. WEEK CODE XXXXX

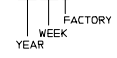

D

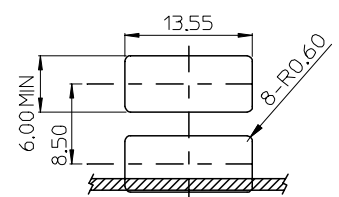
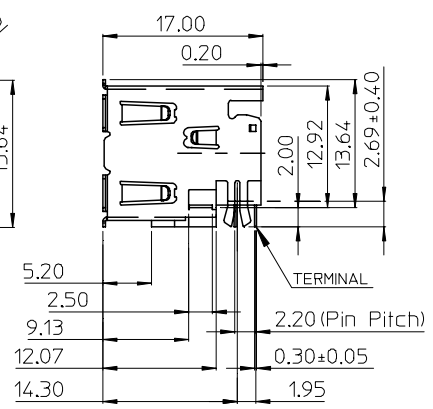
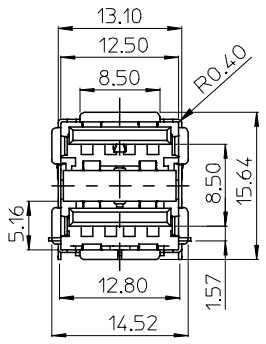

MOUNTING PANEL CUTOUT (INTERNAL SIDE)

C

B

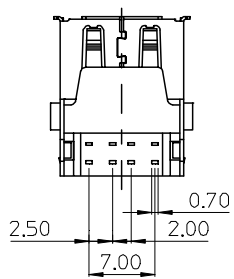

PART NUMBER LEGEND

P/N	CONTACT PLATING	PACKAGE
67298-2090	GOLD FLASH	TRAY
67298-2091	30 MICROINCH GOLD	TRAY
67298-2190	GOLD FLASH	TAPE & REEL
67298-2191	30 MICROINCH GOLD	TAPE & REEL

L/F FOR 67298	DESCRIPTION
EC NO: SH20050520297	2005/05/06
DRWN: JCHEN12	2005/05/10
CHKD: CHKD:	2005/05/10
APPR: MWSCHANG	2005/05/10
REV	

QUALITY SYMBOLS
▽=0
∇=0

GENERAL TOLERANCES (UNLESS SPECIFIED)	DIMENSION STYLE	
	mm	INCH
4 PLACES ± ---	± ---	
3 PLACES ± ---	± ---	
2 PLACES ± 0.25	± ---	
1 PLACE ± 0.25	± ---	
	ANGULAR ± 3 °	
DRAFT WHERE APPLICABLE MUST REMAIN WITHIN DIMENSIONS		

DIMENSION STYLE	
MM ONLY	
DRAWN BY	DATE
IVY-LIN	05/04/18
CHECKED BY	DATE
ALLEN	05/04/18
APPROVED BY	DATE
MWSCHANG	05/04/18
MATERIAL NO.	
SEE TABLE	
SIZE	
A/4	

SCALE	DESIGN UNITS	THIRD ANGLE PROJECTION
	METRIC	
TITLE		
USB DUAL STACKED A CONNECTOR (LEAD FREE VERSION)		
MOLEX INCORPORATED		
DOCUMENT NO.		SHEET NO.
SD-67298-007		1 OF 1
THIS DRAWING CONTAINS INFORMATION THAT IS PROPRIETARY TO MOLEX INCORPORATED AND SHOULD NOT BE USED WITHOUT WRITTEN PERMISSION		

A