



Chipsmall Limited consists of a professional team with an average of over 10 year of expertise in the distribution of electronic components. Based in Hongkong, we have already established firm and mutual-benefit business relationships with customers from,Europe,America and south Asia,supplying obsolete and hard-to-find components to meet their specific needs.

With the principle of “Quality Parts,Customers Priority,Honest Operation,and Considerate Service”,our business mainly focus on the distribution of electronic components. Line cards we deal with include Microchip,ALPS,ROHM,Xilinx,Pulse,ON,Everlight and Freescale. Main products comprise IC,Modules,Potentiometer,IC Socket,Relay,Connector.Our parts cover such applications as commercial,industrial, and automotives areas.

We are looking forward to setting up business relationship with you and hope to provide you with the best service and solution. Let us make a better world for our industry!



Contact us

Tel: +86-755-8981 8866 Fax: +86-755-8427 6832

Email & Skype: info@chipsmall.com Web: www.chipsmall.com

Address: A1208, Overseas Decoration Building, #122 Zhenhua RD., Futian, Shenzhen, China



10 9 8 7 6 5 4 3 2 1

F

E

D

C

B

A

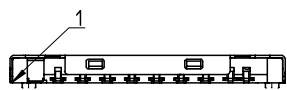
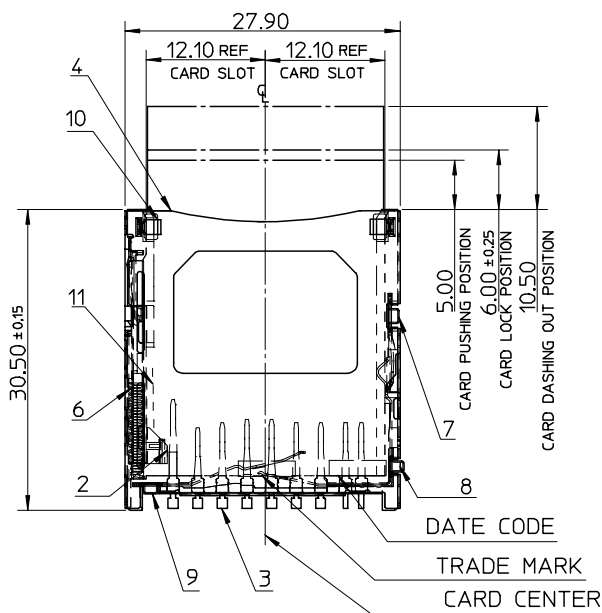
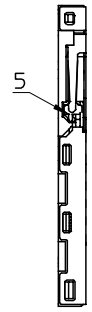
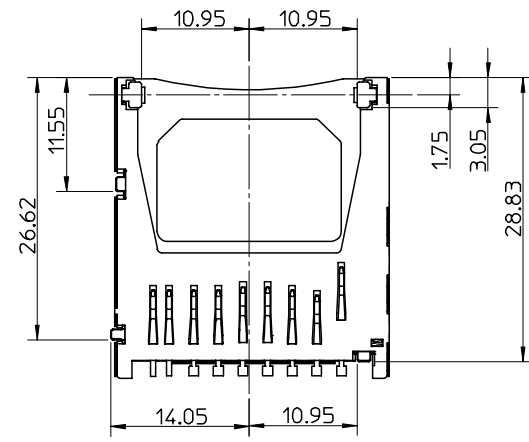
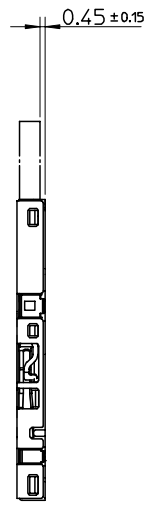
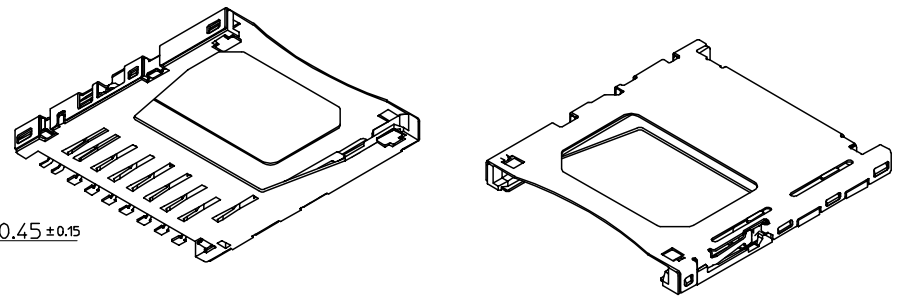
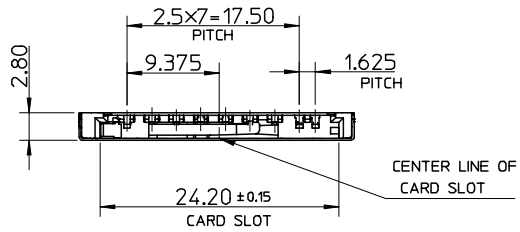

UPDATE DRAWING	2006/10/11
EC NO: SH2007-0231	2006/10/18
DRWN: ZHEN	2006/10/19
CHKD: JIAN	
APPR: JINCHEN	

REV	DESCRIPTION
▽=0	QUALITY SYMBOLS
▽=0	

GENERAL TOLERANCES (UNLESS SPECIFIED)	
4 PLACES ± ---	± ---
3 PLACES ± ---	± ---
2 PLACES ± 0.25	± ---
1 PLACE ± 0.25	± ---
ANGULAR ± 3 °	
DRAFT WHERE APPLICABLE MUST REMAIN WITHIN DIMENSIONS	

DRAWN BY DATE	
DAVID HU	2004/12/20
CHECKED BY DATE	
HARVEY	2004/12/20
APPROVED BY DATE	
VINCENT	2004/12/20
MATERIAL NO.	
676008002	

SCALE 1:1	DESIGN UNITS METRIC	THIRD ANGLE PROJECTION
TITLE		
SD MEMORY CARD CONN. ASS'Y (TOP MOUNT TYPE) LEAD-FREE		
MOLEX INCORPORATED		
DOCUMENT NO.	SHEET NO.	
SD-67600-003	1 OF 3	

9 8 7 6 5 4 3 2 1

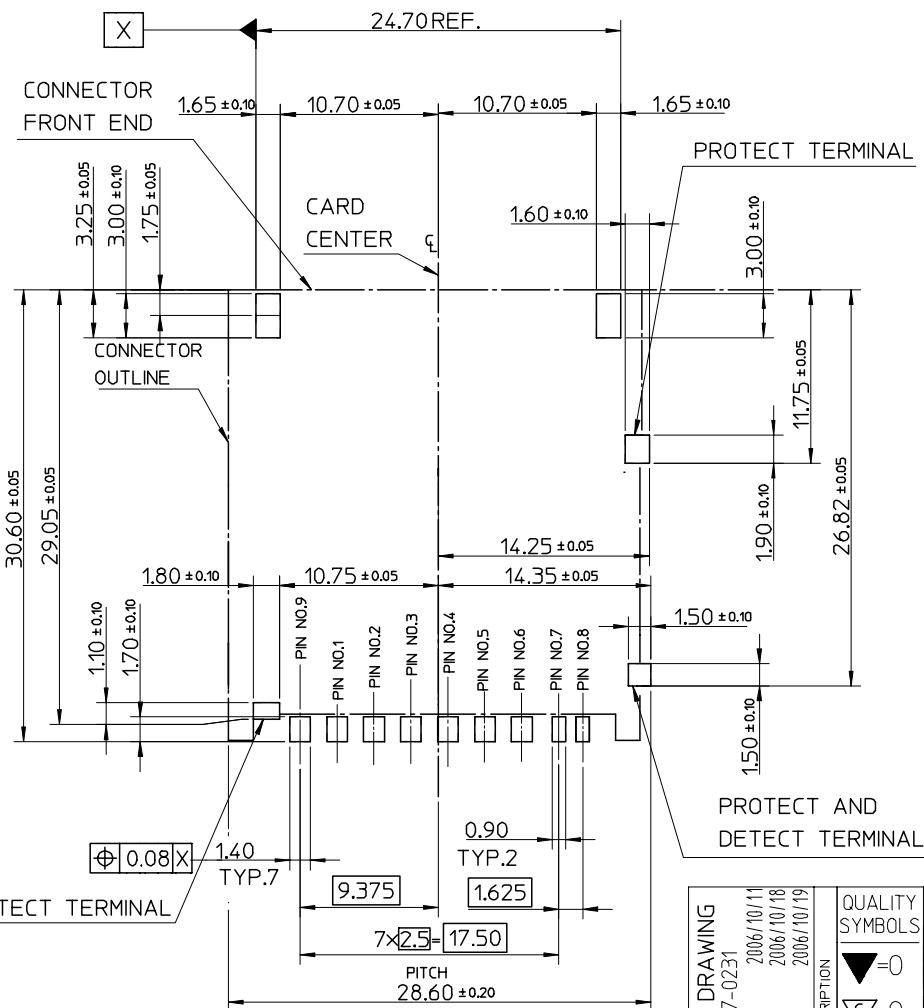

- NOTES:
1. TERMINAL AND NAIL COPLANARITY TO BE 0.1 MAX.
 2. WHEN DELIVERING, THE PUSH/PUSH MECHANISM IS IN THE STATE OF THE UNLOCK. (CARD DASHING OUT POSITION)
 3. CARD READ ONLY BY THE TIME THE CARD DETECTION SWITCH WORKS.
 4. OPENING AND CLOSE OF EACH SWITCH.

CARD INSERTION STATE	WRITE PROTECT SWITCH		CARD DETECT SWITCH
	WRITE PROTECT POSITION	WRITE ENABLE POSITION	
CARD UNINSERTION	OPEN	OPEN	OPEN
CARD HALF INSERTION	CLOSE	CLOSE	OPEN
CARD INSERTION	OPEN	CLOSE	CLOSE

5. TERMINAL PLATING

CONTACT AREA:

- GOLD, THICKNESS=0.2 MICRON MIN.
- SOLDER TAIL AREA(A): TIN, THICKNESS=1.27 MICRON MIN.
- (B): GOLD FLASH, THICKNESS=0.05 MICRON MIN.
- UNDER PLATE: NICKEL, THICKNESS=1 MICRON MIN.

6. PRODUCT SPECIFICATION : PER PS-67600-002

RECOMMENDED PCB PATTERN LAYOUT

UPDATE DRAWING	QUALITY SYMBOLS
EC NO: SH2007-0231	▽=0
DRWN: ZHEN 2006/10/11	◇=0
CHKD: JIAN 2006/10/18	
APPR: JNCHEN 2006/10/19	
REV	DESCRIPTION

GENERAL TOLERANCES (UNLESS SPECIFIED)		DIMENSION STYLE MM ONLY		SCALE 1:1	DESIGN UNITS METRIC	THIRD ANGLE PROJECTION	
	mm	INCH	DRAWN BY DAVID HU	DATE 2004/12/20	TITLE SD MEMORY CARD CONN. ASS'Y (TOP MOUNT TYPE) LEAD-FREE		
4 PLACES	± ---	± ---	CHECKED BY HARVEY	DATE 2004/12/20	MOLEX INCORPORATED		
3 PLACES	± ---	± ---	APPROVED BY VINCENT	DATE 2004/12/20	DOCUMENT NO. SD-67600-003		
2 PLACES	± 0.25	± ---	MATERIAL NO. 676008002		SHEET NO. 2 OF 3		
1 PLACE	± 0.25	± ---	DRAFT WHERE APPLICABLE MUST REMAIN WITHIN DIMENSIONS		THIS DRAWING CONTAINS INFORMATION THAT IS PROPRIETARY TO MOLEX INCORPORATED AND SHOULD NOT BE USED WITHOUT WRITTEN PERMISSION		
ANGULAR ± 3 °							

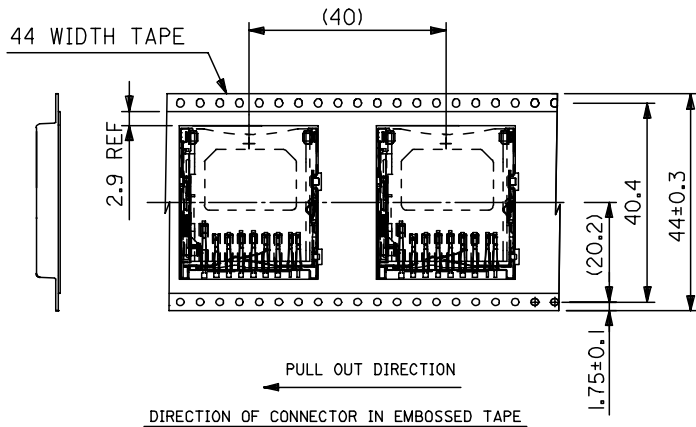
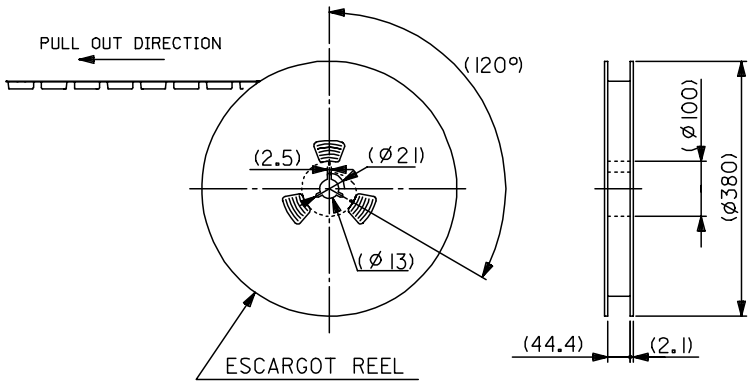

NOTES

1. NUMBER OF CONNECTORS: 400 PCS/REEL
- 2.

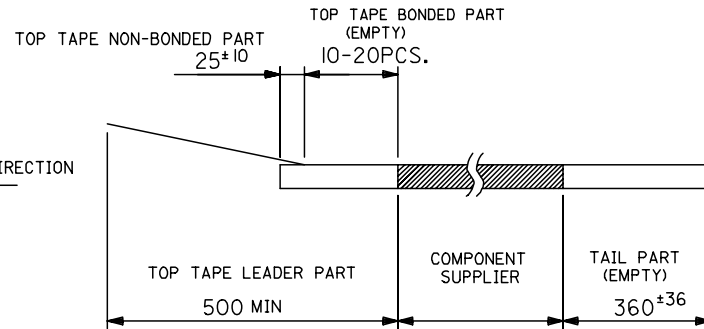

3. PEEL-OFF FORCE OF TOP TAPE: 0.1~1.3 N (10.2~130gf)
(PEELING DIRECTION AS SHOWN IN FOLLOWING FIG.)
<PEEL-OFF SPEED:300mm/min (REF.)>

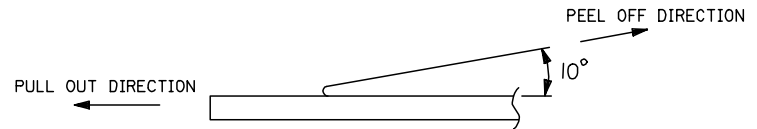

UPDATE DRAWING
EC NO: SH2007-0231
DRWN: ZHEN
CHKD: JIAN
APPR: JICHEN
2006/10/19

QUALITY SYMBOLS
▽=0
▽C=0

GENERAL TOLERANCES (UNLESS SPECIFIED)		DIMENSION STYLE MM ONLY		SCALE 1:1	DESIGN UNITS METRIC	THIRD ANGLE PROJECTION
		mm	INCH			
4 PLACES	± ---	± ---	± ---	DRAWN BY DAVID HU	DATE 2004/12/20	TITLE SD MEMORY CARD CONN. ASS'Y (TOP MOUNT TYPE) LEAD-FREE
3 PLACES	± ---	± ---	± ---	CHECKED BY HARVEY	DATE 2004/12/20	MOLEX INCORPORATED
2 PLACES	± 0.25	± ---	± ---	APPROVED BY VINCENT	DATE 2004/12/20	
1 PLACE	± 0.25	± ---	± ---	MATERIAL NO. 676008002		DOCUMENT NO. SD-67600-003
DRAFT WHERE APPLICABLE MUST REMAIN WITHIN DIMENSIONS		ANGULAR ± 3 °		SHEET NO. 3 OF 3		

SIZE
A3

THIS DRAWING CONTAINS INFORMATION THAT IS PROPRIETARY TO MOLEX INCORPORATED AND SHOULD NOT BE USED WITHOUT WRITTEN PERMISSION