



Chipsmall Limited consists of a professional team with an average of over 10 year of expertise in the distribution of electronic components. Based in Hongkong, we have already established firm and mutual-benefit business relationships with customers from,Europe,America and south Asia,supplying obsolete and hard-to-find components to meet their specific needs.

With the principle of “Quality Parts,Customers Priority,Honest Operation,and Considerate Service”,our business mainly focus on the distribution of electronic components. Line cards we deal with include Microchip,ALPS,ROHM,Xilinx,Pulse,ON,Everlight and Freescale. Main products comprise IC,Modules,Potentiometer,IC Socket,Relay,Connector.Our parts cover such applications as commercial,industrial, and automotives areas.

We are looking forward to setting up business relationship with you and hope to provide you with the best service and solution. Let us make a better world for our industry!



## Contact us

Tel: +86-755-8981 8866 Fax: +86-755-8427 6832

Email & Skype: info@chipsmall.com Web: www.chipsmall.com

Address: A1208, Overseas Decoration Building, #122 Zhenhua RD., Futian, Shenzhen, China





**OBSOLETE**

**APPLICATOR No. 69001-1000**

**PRODUCT No. 90020/21 - 01XX**

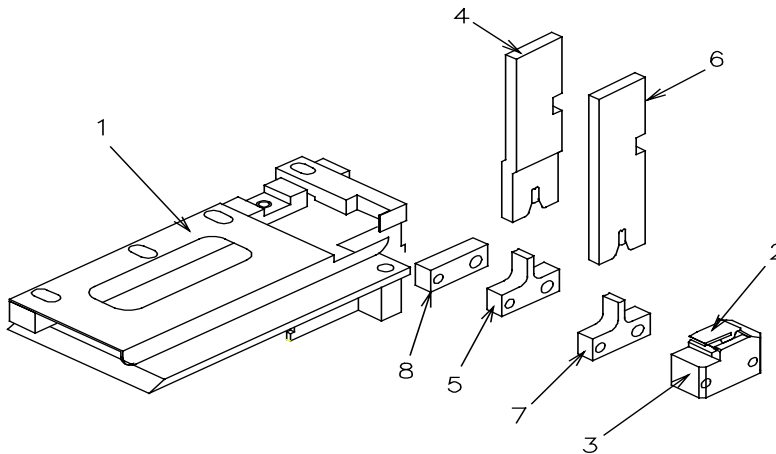

FEED FINGER: 90020-01XX USE 69001-0105, 90021-01XX USE 69001-0106

<u>ITEM</u>	<u>PART NUMBER</u>	<u>DESCRIPTION</u>
1	69001-0000	BASE MODULE (UNTOOLED)
2	69001-0060	SHEAR PUNCH
3	69001-0075	SHEAR DIE
4	69001-0041	CONDUCTOR PUNCH
5	69001-0040	CONDUCTOR ANVIL
6	69001-0021	INSULATION PUNCH
7	69001-0019	INSULATION ANVIL
8	69001-0017	SPACER
9	69001-2001	TOOL KIT (ITEMS 4 - 7)

CRIMP SPECIFICATION: (SEE ALSO PRODUCT SPEC.)

<u>WIRE mm2 (AWG)</u>	<u>CRIMP HEIGHT (COND)</u>	<u>PULL FORCE (MIN)</u>
0.5 (20)	1.28/1.33mm (.050"/.052")	8.2kg (18 lbs)
0.72 (-)	1.36/1.41mm (.053"/.055")	13.2kg (29 lbs)
1.0 (17)	1.43/1.48mm (.056"/.058")	16.3kg (36 lbs)
1.5 (-)	1.47/1.52mm (.058"/.060")	20.9kg (46 lbs)

WIRE STRIP LENGTH: - 3.5/4.0 mm (.138"/.157")