

Chipsmall Limited consists of a professional team with an average of over 10 year of expertise in the distribution of electronic components. Based in Hongkong, we have already established firm and mutual-benefit business relationships with customers from,Europe,America and south Asia,supplying obsolete and hard-to-find components to meet their specific needs.

With the principle of “Quality Parts,Customers Priority,Honest Operation,and Considerate Service”,our business mainly focus on the distribution of electronic components. Line cards we deal with include Microchip,ALPS,ROHM,Xilinx,Pulse,ON,Everlight and Freescale. Main products comprise IC,Modules,Potentiometer,IC Socket,Relay,Connector.Our parts cover such applications as commercial,industrial, and automotives areas.

We are looking forward to setting up business relationship with you and hope to provide you with the best service and solution. Let us make a better world for our industry!



Contact us

Tel: +86-755-8981 8866 Fax: +86-755-8427 6832

Email & Skype: info@chipsmall.com Web: www.chipsmall.com

Address: A1208, Overseas Decoration Building, #122 Zhenhua RD., Futian, Shenzhen, China

CKT. SIZE	"A"		"B" REF.		"C" REF.		"F" REF.		"M"		"R" REF.		"V" REF.	
	MM	IN.	MM	IN.	MM	IN.	MM	IN.	MM	IN.	MM	IN.	MM	IN.
2	2.54	.100	5.33	.210	7.37	.290	8.63	.340	12.40	.488	5.33	.210	10.67	.420
3	5.08	.200	8.13	.320	10.16	.400	11.43	.450	14.94	.588	7.87	.310	13.21	.520
4	7.62	.300	10.67	.420	12.70	.500	13.97	.550	17.48	.688	10.41	.410	15.75	.620
5	10.16	.400	13.21	.520	15.24	.600	16.51	.650	20.02	.788	12.95	.510	18.29	.720
6	12.70	.500	15.75	.620	17.78	.700	19.05	.750	22.56	.888	15.49	.610	20.83	.820
7	15.24	.600	18.29	.720	20.32	.800	21.59	.850	25.10	.988	18.03	.710	23.37	.920
8	17.78	.700	20.83	.820	22.86	.900	24.13	.950	27.64	1.088	20.57	.810	25.91	1.020
9	20.32	.800	23.37	.920	25.40	1.000	26.67	1.050	30.18	1.188	23.11	.910	28.45	1.120
10	22.86	.900	25.91	1.020	27.94	1.100	29.21	1.150	32.72	1.288	25.65	1.010	30.99	1.220
11	25.40	1.000	28.45	1.120	30.48	1.200	31.75	1.250	35.26	1.388	28.19	1.110	33.53	1.320
12	27.94	1.100	30.99	1.220	33.02	1.300	34.29	1.350	37.80	1.488	30.73	1.210	36.07	1.420
13	30.48	1.200	33.53	1.320	35.56	1.400	36.83	1.450	40.34	1.588	33.27	1.310	38.61	1.520
14	33.02	1.300	36.07	1.420	38.10	1.500	39.37	1.550	42.88	1.688	35.81	1.410	41.15	1.620
15	35.56	1.400	38.61	1.520	40.64	1.600	41.91	1.650	45.42	1.788	38.35	1.510	43.69	1.720
16	38.10	1.500	41.15	1.620	43.18	1.700	44.45	1.750	47.96	1.888	40.89	1.610	46.23	1.820
17	40.64	1.600	43.69	1.720	45.72	1.800	46.99	1.850	50.50	1.988	43.43	1.710	48.77	1.920
18	43.18	1.700	46.23	1.820	48.26	1.900	49.53	1.950	53.04	2.088	45.97	1.810	51.31	2.020
19	45.72	1.800	48.77	1.920	50.80	2.000	52.07	2.050	55.58	2.188	48.51	1.910	53.85	2.120
20	48.26	1.900	51.31	2.020	53.34	2.100	54.61	2.150	58.12	2.288	51.05	2.010	56.39	2.220
21	50.80	2.000	53.85	2.120	55.88	2.200	57.15	2.250	60.66	2.388	53.59	2.110	58.93	2.320
22	53.34	2.100	56.39	2.220	58.42	2.300	59.69	2.350	63.20	2.488	56.13	2.210	61.47	2.420
23	55.88	2.200	58.93	2.320	60.96	2.400	62.23	2.450	65.74	2.588	58.67	2.310	64.01	2.520
24	58.42	2.300	61.47	2.420	63.50	2.500	64.37	2.550	68.28	2.688	61.21	2.410	66.55	2.620
25	60.96	2.400	64.01	2.520	66.04	2.600	67.31	2.650	70.82	2.788	63.75	2.510	69.09	2.720

NOTES

- 1) MATERIAL:
HOUSING - GLASS FILLED POLYESTER, UL 94V-0, COLOR: BLACK.
PIN - (0.64)/.025 SQUARE PHOSPHOR BRONZE BASE MATERIAL.
FOR PLATING SEE TABLES ON FOLLOWING SHEETS.
- 2) HEADER TO BE USED WITH 70400-**** AND 70430-**** AND 70066 OPTION "G" SERIES.
- 3) REFER TO MOLEX PRODUCT SPECIFICATIONS PS-70541 AND PS-70400.
- 4) FOR VOID LOCATION(S) SEE TABLES ON FOLLOWING SHEETS.
- 5) FOR ILLUSTRATION PURPOSES 4 CIRCUIT WITH CIRCUIT 2 VOIDED IS SHOWN.

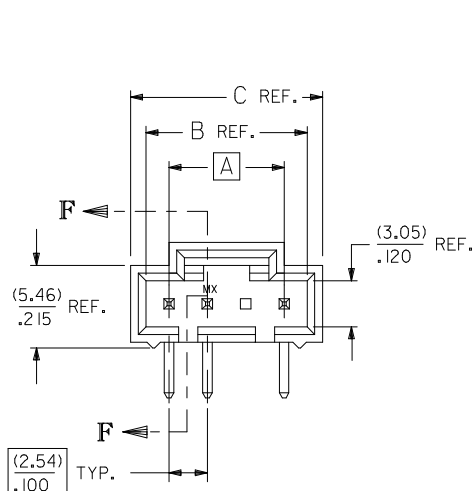
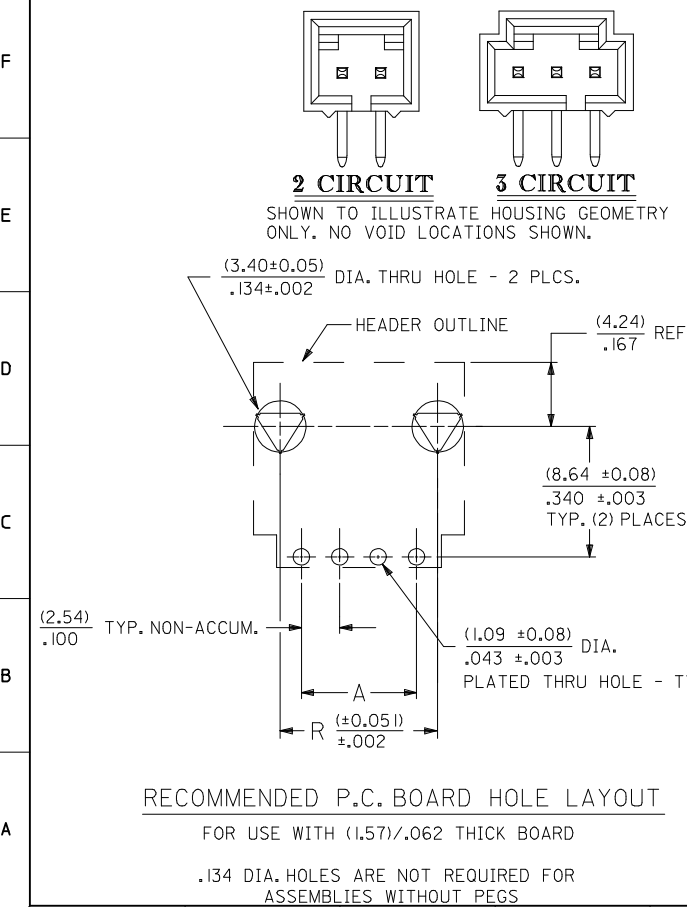

RIGHT ANGLE ASSEMBLY

OTHER VERTICAL AND RIGHT ANGLE VERSIONS SHOWN ON SHEET 2

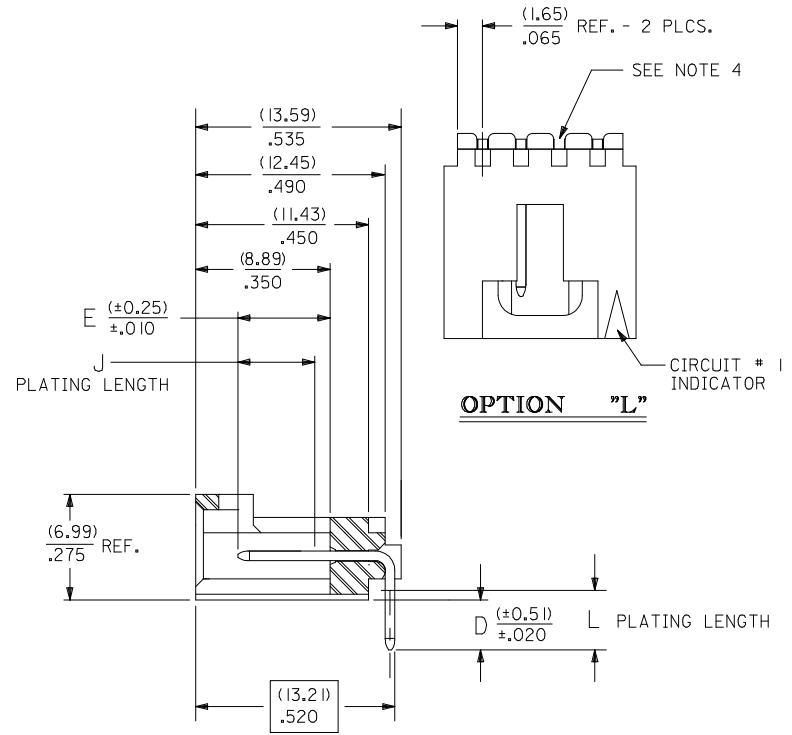

SECTION F-F

CHG 71164-0044 R/A EC NO: UCP2014-4433 DRWINGMORGAN 2014/04/24 CHKD:MPOFF 2014/04/24 APPR:SMILLER 2014/05/10 REV: T1	QUALITY SYMBOLS ▽=0 ▽=0 ▽=0	GENERAL TOLERANCES (UNLESS SPECIFIED) <table border="1"> <tr> <th></th> <th>mm</th> <th>INCH</th> </tr> <tr> <td>4 PLACES</td> <td>± .---</td> <td>± .---</td> </tr> <tr> <td>3 PLACES</td> <td>± .---</td> <td>± .005</td> </tr> <tr> <td>2 PLACES</td> <td>± 0.13</td> <td>± .010</td> </tr> <tr> <td>1 PLACE</td> <td>± 0.25</td> <td>± .---</td> </tr> <tr> <td>0 PLACE</td> <td>±</td> <td>±</td> </tr> </table>		mm	INCH	4 PLACES	± .---	± .---	3 PLACES	± .---	± .005	2 PLACES	± 0.13	± .010	1 PLACE	± 0.25	± .---	0 PLACE	±	±	DIMENSION STYLE MM/IN DRAWN BY DATE BJS 1994/09/30 CHECKED BY DATE	SCALE 4:1 DESIGN UNITS INCH	THIRD ANGLE PROJECTION
		mm	INCH																				
	4 PLACES	± .---	± .---																				
	3 PLACES	± .---	± .005																				
2 PLACES	± 0.13	± .010																					
1 PLACE	± 0.25	± .---																					
0 PLACE	±	±																					
ANGULAR ±1/2°		APPROVED BY DATE SMILLER 2010/05/10	SALES ASSY, HEADER .120 POCKET/HIGH TEMP 2.54/.100 CENTER W/VOIDS molex																				
DRAFT WHERE APPLICABLE MUST REMAIN WITHIN DIMENSIONS		MATERIAL NO. SEE TABLE	DOCUMENT NO. SDA-71164-****	SHEET NO. 1 OF 4																			
THIS DRAWING CONTAINS INFORMATION THAT IS PROPRIETARY TO MOLEX INCORPORATED AND SHOULD NOT BE USED WITHOUT WRITTEN PERMISSION																							

VERTICAL ASSEMBLIES

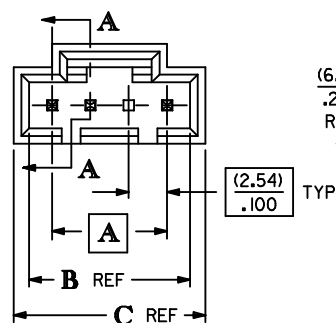
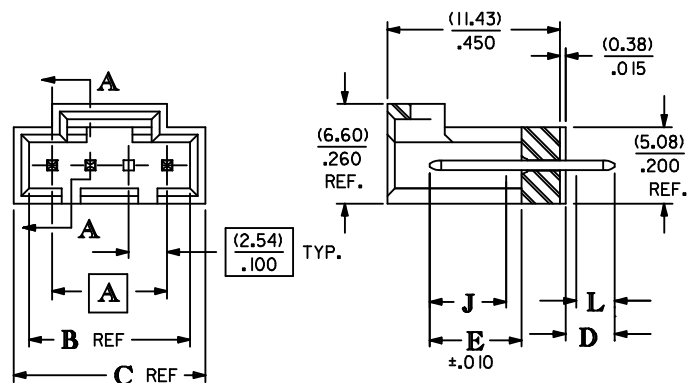
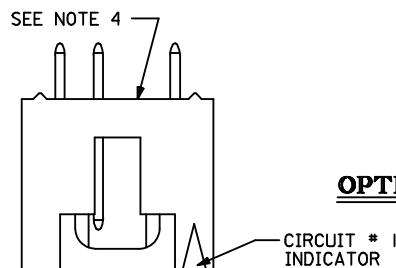
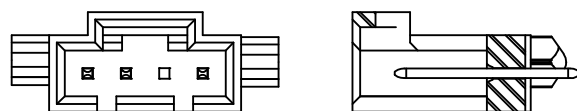
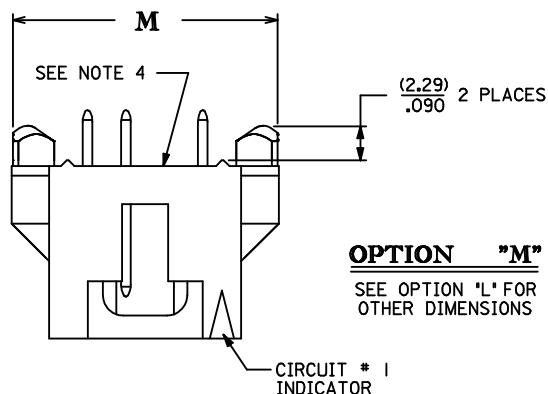

RIGHT ANGLE ASSEMBLIES

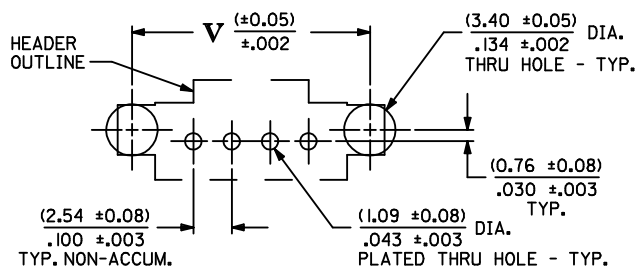
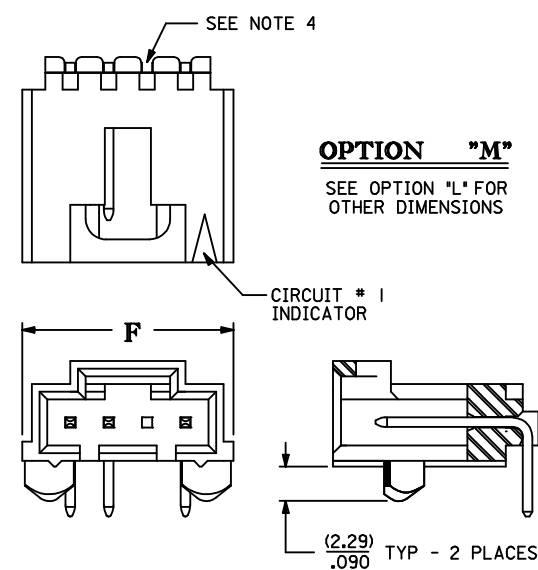

FOR USE WITH (1.57)/.062 THICK BOARD
.134 DIA. HOLES ARE NOT REQUIRED FOR ASSEMBLIES WITHOUT PEGS

SEE SHEET 1 EC NO: UCP2014-4433 DRW:DMORGAN 2014/04/24 CHKD:RPOFF 2014/04/24 APPR:SMILLER 2014/05/06	QUALITY SYMBOLS ▽=0 ▽=0 ▽=0	GENERAL TOLERANCES (UNLESS SPECIFIED)	DIMENSION STYLE MM/IN	SCALE 4:1	DESIGN UNITS INCH	THIRD ANGLE PROJECTION
		4 PLACES ± --- ± --- 3 PLACES ± --- ± .005 2 PLACES ± 0.13 ± .010 1 PLACE ± 0.25 ± --- 0 PLACE ± ±	DRAWN BY BJS	DATE 1994/09/30	TITLE SALES ASSY, HEADER .120 POCKET/HIGH TEMP 2.54/.100 CENTER W/VOIDS	molex
T1	DESCRIPTION	ANGULAR ±1/2°	APPROVED BY SMILLER	DATE 2010/05/10	DOCUMENT NO. SDA-71164-****	SHEET NO. 2 OF 4
DRAFT WHERE APPLICABLE MUST REMAIN WITHIN DIMENSIONS		SIZE C	THIS DRAWING CONTAINS INFORMATION THAT IS PROPRIETARY TO MOLEX INCORPORATED AND SHOULD NOT BE USED WITHOUT WRITTEN PERMISSION			

ITEM NO.	ASSEMBLY TYPE	HOUSING OPTION	CKT. SIZE	VOIDED PIN LOCATION - CIRCUIT NUMBER(S)	"D" (±0.51) ±.020	"E" (±0.25) ±.010	PLATING CODE	CONNECTOR END PLATING		P.C. BOARD END PLATING		PACKAGE PER PK-70873
								TYPE	J LENGTH	TYPE	L LENGTH	
71164-0001	RIGHT ANGLE	"M"	3	2	(3.30) .130	(6.10) .240	TIN	TIN	OVER-ALL	TIN	OVER-ALL	-0015
71164-0002	RIGHT ANGLE	"M"	4	2	(3.30) .130	(6.10) .240	15 GOLD	GOLD	(5.08) .200	TIN	(2.54) .100	-0015
71164-0003	RIGHT ANGLE	"M"	4	3	(3.30) .130	(6.10) .240	15 GOLD	GOLD	(5.08) .200	TIN	(2.54) .100	-0015
71164-0004	RIGHT ANGLE	"M"	4	4	(3.30) .130	(6.10) .240	15 GOLD	GOLD	(5.08) .200	TIN	(2.54) .100	-0015
71164-0005	RIGHT ANGLE	"L"	8	2, 7	(3.30) .130	(6.10) .240	TIN	TIN	OVER-ALL	TIN	OVER-ALL	-0015
71164-0006	VERTICAL	"M"	7	2, 5	(3.30) .130	(6.10) .240	15 GOLD	GOLD	(5.08) .200	TIN	(2.54) .100	-0014
71164-0007	VERTICAL	"L"	3	3	(3.30) .130	(6.10) .240	15 GOLD	GOLD	(5.08) .200	TIN	(2.54) .100	-0014
71164-0008	VERTICAL	"M"	3	2	(3.30) .130	(6.10) .240	15 GOLD	GOLD	(5.08) .200	TIN	(2.54) .100	-0014
71164-0010	VERTICAL	"L"	6	2	(3.30) .130	(6.10) .240	30 GOLD	GOLD	(5.08) .200	TIN	(2.54) .100	-0014
71164-0011	VERTICAL	"L"	11	5, 6	(3.30) .130	(6.10) .240	TIN	TIN	OVER-ALL	TIN	OVER-ALL	-0014
71164-0012	VERTICAL	"L"	4	3	(3.30) .130	(6.10) .240	TIN	TIN	OVER-ALL	TIN	OVER-ALL	-0014
71164-0014	VERTICAL	"L"	11	11	(3.30) .130	(6.10) .240	15 GOLD	GOLD	(5.08) .200	TIN	(2.54) .100	-0014
71164-0015	VERTICAL	"L"	10	4	(3.30) .130	(6.10) .240	15 GOLD	GOLD	(5.08) .200	TIN	(2.54) .100	-0014
71164-0016	VERTICAL	"L"	11	2	(3.30) .130	(6.10) .240	15 GOLD	GOLD	(5.08) .200	TIN	(2.54) .100	-0014
71164-0017	VERTICAL	"L"	8	2, 7	(3.30) .130	(6.10) .240	TIN	TIN	OVER-ALL	TIN	OVER-ALL	-0014
71164-0018	VERTICAL	"L"	7	2, 4, 6	(3.30) .130	(6.10) .240	15 GOLD	GOLD	(5.08) .200	TIN	(2.54) .100	-0014
71164-0019	VERTICAL	"L"	7	2, 4, 6	(3.30) .130	(6.10) .240	30 GOLD	GOLD	(5.08) .200	TIN	(2.54) .100	-0014
71164-0020	VERTICAL	"L"	11	2, 4, 6, 8, 10	(3.30) .130	(6.10) .240	30 GOLD	GOLD	(5.08) .200	TIN	(2.54) .100	-0014
71164-0021	VERTICAL	"L"	15	2, 4, 6, 8, 10, 12, 14	(3.30) .130	(6.10) .240	30 GOLD	GOLD	(5.08) .200	TIN	(2.54) .100	-0014
71164-0022	VERTICAL	"M"	7	3, 6	(3.30) .130	(6.10) .240	15 GOLD	GOLD	(5.08) .200	TIN	(2.54) .100	-0014
71164-0023	VERTICAL	"L"	11	10	(3.81) .150	(6.10) .240	TIN	TIN	OVER-ALL	TIN	OVER-ALL	-0014
71164-0024	VERTICAL	"L"	19	17	(3.81) .150	(6.10) .240	TIN	TIN	OVER-ALL	TIN	OVER-ALL	-0014
71164-0025	VERTICAL	"L"	20	19	(3.81) .150	(6.10) .240	TIN	TIN	OVER-ALL	TIN	OVER-ALL	-0014

TIN - 3.81 MICROMETER/(150 MICROINCH) MINIMUM TIN PLATE IN SELECT AREA, OVER 1.27 MICROMETER/(50 MICROINCH) MINIMUM NICKEL UNDERPLATE.

30 GOLD - .76 MICROMETER/(30 MICROINCH) MINIMUM GOLD PLATE IN SELECT AREA, 1.91 MICROMETER/(75 MICROINCH) MINIMUM TIN PLATE IN SELECT AREA, OVER 1.27 MICROMETER/(50 MICROINCH) MINIMUM NICKEL UNDERPLATE.

15 GOLD - .38 MICROMETER/(15 MICROINCH) MINIMUM GOLD PLATE IN SELECT AREA, 1.91 MICROMETER/(75 MICROINCH) MINIMUM TIN PLATE IN SELECT AREA, OVER 1.27 MICROMETER/(50 MICROINCH) MINIMUM NICKEL UNDERPLATE.

SEE SHEET 1 EC NO: UCP2014-4433 DRWING:MORGAN 2014/04/24 CHKD:MPOFF 2014/04/24 APPR:SMILLER 2014/05/06 T1	QUALITY SYMBOLS	GENERAL TOLERANCES (UNLESS SPECIFIED)	DIMENSION STYLE	SCALE	DESIGN UNITS	THIRD ANGLE PROJECTION
	▽=0	4 PLACES ± --- ± ---	MM/IN	1:1	INCH	SALES ASSY, HEADER .120 POCKET/HIGH TEMP 2.54/.100 CENTER W/VOIDS molex
	▽=0	3 PLACES ± --- ± .005	DRAWN BY DATE	CHECKED BY DATE	TITLE	
	▽=0	2 PLACES ± 0.13 ± .010	1 PLACE ± 0.25 ± ---	APPROVED BY DATE	SMILLER 2010/05/10	DOCUMENT NO.
	0 PLACE ± ±	ANGULAR ±1/2°	SEE TABLE		SDA-71164-****	3 OF 4
DRAFT WHERE APPLICABLE MUST REMAIN WITHIN DIMENSIONS			THIS DRAWING CONTAINS INFORMATION THAT IS PROPRIETARY TO MOLEX INCORPORATED AND SHOULD NOT BE USED WITHOUT WRITTEN PERMISSION			

ITEM NO.	ASSEMBLY TYPE	HOUSING OPTION	CKT. SIZE	VOIDED PIN LOCATION - CIRCUIT NUMBER(S)	"D"	"E"	PLATING CODE	CONNECTOR END PLATING		P.C. BOARD END PLATING		PACKAGE PER PK-70873
					(±0.51) ±.020	(±0.25) ±.010		TYPE	J LENGTH	TYPE	L LENGTH	
71164-0026	VERTICAL	"L"	16	3, 5, 7, 9, 11, 13, 15	(3.30) .130	(6.10) .240	I5 GOLD	GOLD	(5.08) .200	TIN	(2.54) .100	-0014
71164-0027	VERTICAL	"L"	11	10	(3.30) .130	(6.10) .240	TIN	TIN	OVER-ALL	TIN	OVER-ALL	-0014
71164-0028	VERTICAL	"L"	20	19	(3.30) .130	(6.10) .240	TIN	TIN	OVER-ALL	TIN	OVER-ALL	-0014
71164-0029	VERTICAL	"L"	5	2,4	(3.30) .130	(6.10) .240	TIN	TIN	OVER-ALL	TIN	OVER-ALL	-0014
71164-0030	VERTICAL	"L"	7	7	(3.30) .130	(6.10) .240	TIN	TIN	OVER-ALL	TIN	OVER-ALL	-0014
71164-0031	VERTICAL	"L"	16	15	(3.30) .130	(6.10) .240	I5 GOLD	GOLD	(5.08) .200	TIN	(2.54) .100	-0014
71164-0032	VERTICAL	"L"	20	19	(3.81) .150	(6.10) .240	I5 GOLD	GOLD	(5.08) .200	TIN	(2.54) .100	-0014
71164-0033	RIGHT ANGLE	"L"	3	2	(3.30) .130	(6.10) .240	I5 GOLD	GOLD	(5.08) .200	TIN	(2.54) .100	-0015
71164-0034	VERTICAL	"L"	5	2	(3.30) .130	(6.10) .240	TIN	TIN	OVER-ALL	TIN	OVER-ALL	-0014
71164-0035	VERTICAL	"L"	12	4	(3.30) .130	(6.10) .240	TIN	TIN	OVER-ALL	TIN	OVER-ALL	-0014
71164-0036	VERTICAL	"L"	3	2	(3.30) .130	(6.10) .240	I5 GOLD	TIN	(5.08) .200	TIN	(2.54) .100	-0014
71164-0037	VERTICAL	"L"	12	10	(3.30) .130	(6.10) .240	I5 GOLD	GOLD	OVER-ALL	TIN	OVER-ALL	-0014
71164-0038	VERTICAL	"L"	3	2	(3.30) .130	(6.10) .240	TIN	TIN	OVER-ALL	TIN	OVER-ALL	-0014
71164-0039	VERTICAL	"L"	8	1,3,5,7	(3.30) .130	(6.10) .240	TIN	TIN	OVER-ALL	TIN	OVER-ALL	-0014
71164-0040	VERTICAL	"L"	24	13,5,7,9,11,13,15,17,19,21,23	(3.30) .130	(6.10) .240	TIN	TIN	OVER-ALL	TIN	OVER-ALL	-0014
71164-0041	VERTICAL	"L"	4	1	(3.30) .130	(6.10) .240	TIN	TIN	OVER-ALL	TIN	OVER-ALL	-0014
71164-0042	VERTICAL	"L"	4	2	(3.30) .130	(6.10) .240	TIN	TIN	OVER-ALL	TIN	OVER-ALL	-0014
71164-0043	VERTICAL	"L"	4	3	(3.30) .130	(6.10) .240	TIN	TIN	OVER-ALL	TIN	OVER-ALL	-0014
71164-0044	RIGHT ANGLE	"M"	10	2,3,4,6,7,8,9	(3.30) .130	(6.10) .240	I5 GOLD	GOLD	(5.08) .200	TIN	(2.54) .100	-0015

TIN - 3.81 MICROMETER/(150 MICROINCH) MINIMUM TIN PLATE IN SELECT AREA, OVER 1.27 MICROMETER/(50 MICROINCH) MINIMUM NICKEL UNDERPLATE.

30 GOLD - .76 MICROMETER/(30 MICROINCH) MINIMUM GOLD PLATE IN SELECT AREA, 1.91 MICROMETER/(75 MICROINCH) MINIMUM TIN PLATE IN SELECT AREA, OVER 1.27 MICROMETER/(50 MICROINCH) MINIMUM NICKEL UNDERPLATE.

15 GOLD - .38 MICROMETER/(15 MICROINCH) MINIMUM GOLD PLATE IN SELECT AREA, 1.91 MICROMETER/(75 MICROINCH) MINIMUM TIN PLATE IN SELECT AREA, OVER 1.27 MICROMETER/(50 MICROINCH) MINIMUM NICKEL UNDERPLATE.

SEE SHEET 1 EC NO: UCP2014-4433 DRWING: MORGAN 2014/04/24 CHKD: MPOFF 2014/04/24 APPR: SMILLER 2014/05/06	QUALITY SYMBOLS 	GENERAL TOLERANCES (UNLESS SPECIFIED)		DIMENSION STYLE		SCALE	DESIGN UNITS	THIRD ANGLE PROJECTION
				MM/IN		1:1	INCH	
DRAWN BY BJS CHECKED BY DATE APPROVED BY SMILLER DATE 2010/05/10 MATERIAL NO. SEE TABLE DOCUMENT NO. SDA-71164-**** SHEET NO. 4 OF 4	4 PLACES ± --- ± --- 3 PLACES ± --- ± .005 2 PLACES ± 0.13 ± .010 1 PLACE ± 0.25 ± --- 0 PLACE ± ±		mm INCH DATE 1994/09/30 DATE DATE 2010/05/10		TITLE SALES ASSY, HEADER .120 POCKET/HIGH TEMP 2.54/.100 CENTER W/VOIDS molex			
	ANGULAR ±1/2°		DRAFT WHERE APPLICABLE MUST REMAIN WITHIN DIMENSIONS		THIS DRAWING CONTAINS INFORMATION THAT IS PROPRIETARY TO MOLEX INCORPORATED AND SHOULD NOT BE USED WITHOUT WRITTEN PERMISSION			