



Chipsmall Limited consists of a professional team with an average of over 10 year of expertise in the distribution of electronic components. Based in Hongkong, we have already established firm and mutual-benefit business relationships with customers from,Europe,America and south Asia,supplying obsolete and hard-to-find components to meet their specific needs.

With the principle of “Quality Parts,Customers Priority,Honest Operation,and Considerate Service”,our business mainly focus on the distribution of electronic components. Line cards we deal with include Microchip,ALPS,ROHM,Xilinx,Pulse,ON,Everlight and Freescale. Main products comprise IC,Modules,Potentiometer,IC Socket,Relay,Connector.Our parts cover such applications as commercial,industrial, and automotives areas.

We are looking forward to setting up business relationship with you and hope to provide you with the best service and solution. Let us make a better world for our industry!



Contact us

Tel: +86-755-8981 8866 Fax: +86-755-8427 6832

Email & Skype: info@chipsmall.com Web: www.chipsmall.com

Address: A1208, Overseas Decoration Building, #122 Zhenhua RD., Futian, Shenzhen, China



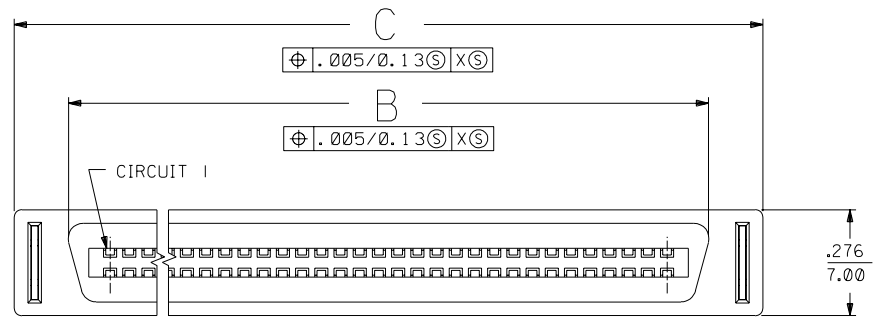

NOTES:

- 1) MATERIALS:
HOUSING- LCP, GLASS FILLED, 94V-0, BLACK.
TERMINALS- COPPER ALLOY
METAL PEGS- COPPER ALLOY
 - 2) PLATING:
.000030 INCHES MINIMUM GOLD IN SELECTIVE CONTACT AREA
OVER .000050 INCHES MINIMUM NICKEL IN CONTACT AREA.
.000100 INCHES MINIMUM TIN IN SOLDER TAIL AREA.
 - 3) ASSEMBLY MATES WITH MOLEX P/N SDA-71661-****.
CONFORMS TO PRODUCT SPECIFICATION PS-71660.
- ⚠ RECOMMENDED P.C. BOARD THICKNESS IS .062 (1.6).
- ⚠ CONNECTOR WILL ACCEPT MATING TO A P.C. BOARD WITH A THICKNESS OF .062±.003.

NOTE FOR LEAD FREE CONVERSION:

THE PRIMARY SHIPPING CARTON WILL BE LABELED "COMPLIANT TO RoHS DIRECTIVE 2002/95/EC AND ELV ANNEX II OF DIRECTIVE 2000/53/EC". CARTONS WITHOUT THIS LABEL MAY CONTAIN PRODUCT WITH LEAD.

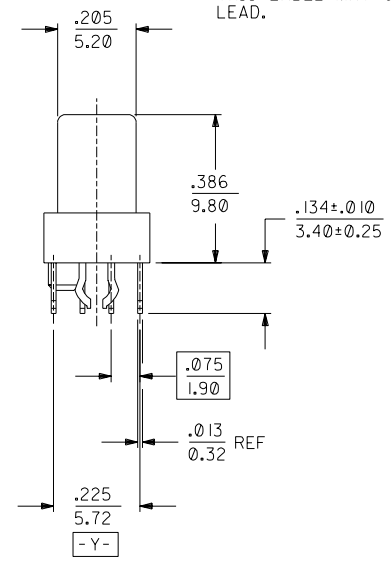
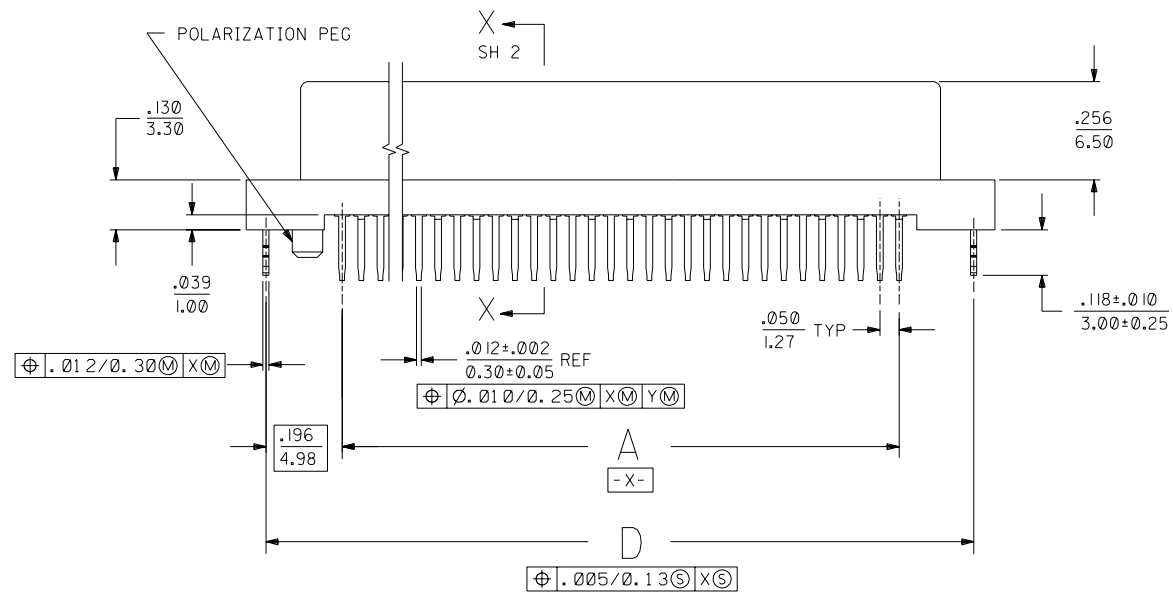

D	LEAD FREE CONV ECN UCP2004-2096 RKADAMS 04/04/23
C	REVISED ECN LDT 2000-1231 ACHAMMER 00/06/07
B	REVISED PER ECN U40506 4-15-94 RAN
A	INITIAL RELEASE PER ECN U31655 11-5-93 RAN

DIMENSIONS SHOWN (METRIC) INCH UNLESS OTHERWISE SPECIFIED TOLERANCES: ANGULAR ± 1/2°		▽ = 0		= 0		REVISE ONLY ON CAD SYSTEM	
3 PLACE	± .005	---					
2 PLACE	± .01	± 0.13					
1 PLACE	---	± 0.25					
DRAFT WHERE APPLICABLE MUST REMAIN WITHIN DIMENSIONS							
DRWG. BY	RAN	CHK'D. BY	RAN	FILE NAME	57166095	SHEET NO.	1 OF 2
APP'D. BY	CAB	SCALE	4: 1	THIS DRAWING CONTAINS INFORMATION THAT IS PROPRIETARY TO MOLEX INC. AND SHOULD NOT BE USED WITHOUT WRITTEN PERMISSION.	DATE	11 / 5 / 93	U.S.A.
				SEE TABLE		SDA-71660-95**	
				MOLEX INCORPORATED		LITSE, ILL. 60532	

