



Chipsmall Limited consists of a professional team with an average of over 10 year of expertise in the distribution of electronic components. Based in Hongkong, we have already established firm and mutual-benefit business relationships with customers from,Europe,America and south Asia,supplying obsolete and hard-to-find components to meet their specific needs.

With the principle of “Quality Parts,Customers Priority,Honest Operation,and Considerate Service”,our business mainly focus on the distribution of electronic components. Line cards we deal with include Microchip,ALPS,ROHM,Xilinx,Pulse,ON,Everlight and Freescale. Main products comprise IC,Modules,Potentiometer,IC Socket,Relay,Connector.Our parts cover such applications as commercial,industrial, and automotives areas.

We are looking forward to setting up business relationship with you and hope to provide you with the best service and solution. Let us make a better world for our industry!



## Contact us

Tel: +86-755-8981 8866 Fax: +86-755-8427 6832

Email & Skype: info@chipsmall.com Web: www.chipsmall.com

Address: A1208, Overseas Decoration Building, #122 Zhenhua RD., Futian, Shenzhen, China



MATERIALS AND FINISHES

BODY: BRASS  
PLATED TRI-M

CONTACT: BRASS  
PLATED SILVER

INSULATOR: TEFLON

COUPLING NUT: BRASS  
PLATED NICKEL

O-RING: SILICONE RUBBER

NOTE: CONNECTORS SHIPPED  
WITH POLYETHYLENE  
DUST CAP

PERFORMANCE REQUIREMENTS:

FREQUENCY RANGE: 0-6GHz  
IMPEDANCE: 50 OHM  
WITHSTAND VOLTAGE(AC): 2500V @0,5mA  
VSWR: ≤1.10(0-3GHz)  
PIM3(2x20W): ≤-165dBc@1800MHz  
WATER-PROOF: IP68 WHEN MATED

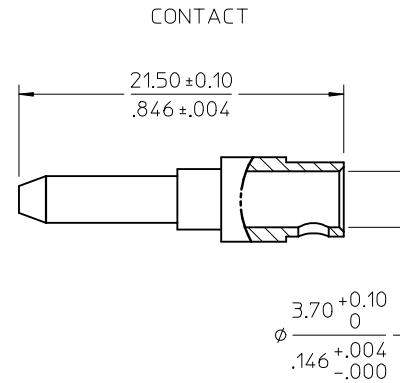
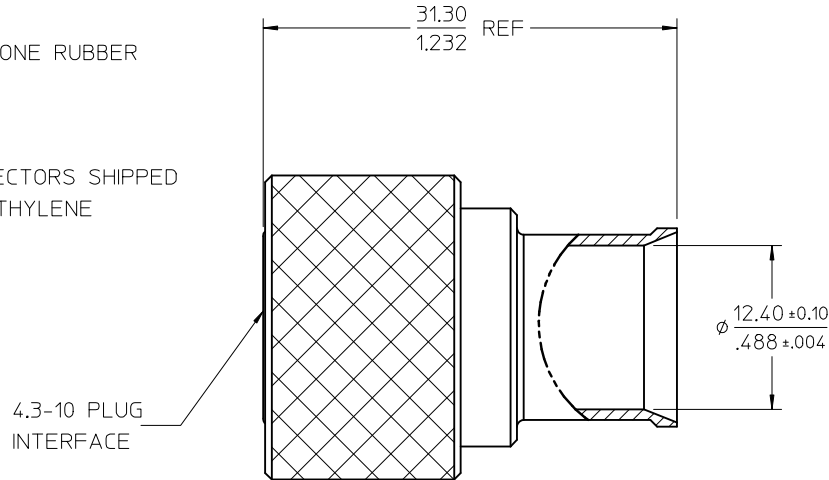
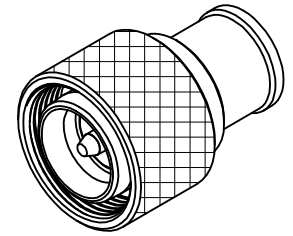

INSULATOR SPACER

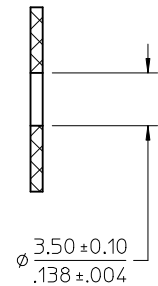

73162-6171	ONE PIECE PER CARTON
73162-6170	BLANK
PART NO.	PACKAGING

IEC61169-54	INTERFACE
SPECIFICATION	DESCRIPTION

CHG: AND PACKAG.  
PIM3 -165dBc WAS  
-160dBc. PN.73162  
WAS 73134

EC NO: URF2016-0691  
DRAWN:YHUANG11 2016/04/15  
CHKD:  
APPR:MYE08 2016/04/20

REV	DESCRIPTION	QUALITY SYMBOLS
A1		▽=0
		▽=0
		▽=0

GENERAL TOLERANCES (UNLESS SPECIFIED)

	mm	INCH
4 PLACES	± .004	± .0001
3 PLACES	± .003	± .0001
2 PLACES	± .002	± .0001
1 PLACE	± .001	± .0001
0 PLACE	± .0005	± .0001

ANGULAR ± 2°

DRAFT WHERE APPLICABLE MUST REMAIN WITHIN DIMENSIONS

DIMENSION STYLE		SCALE	DESIGN UNITS	THIRD ANGLE PROJECTION
MM/IN			METRIC	☉
DRAWN BY	DATE	TITLE		
YHUANG11	2015/12/03	4.3-10 PLUG, 50 OHM FOR 1/2SF CA, SOLDERING 4.3-10-PS,HAND-TIGHT		
CHECKED BY	DATE	<b>molex</b>		
MXU11	2015/12/03			
APPROVED BY	DATE	MATERIAL NO.	DOCUMENT NO.	SHEET NO.
MYE08	2016/02/01	SEE TABLE	SD-73162-617	1 OF 2

THIS DRAWING CONTAINS INFORMATION THAT IS PROPRIETARY TO MOLEX INCORPORATED AND SHOULD NOT BE USED WITHOUT WRITTEN PERMISSION

STEP 2

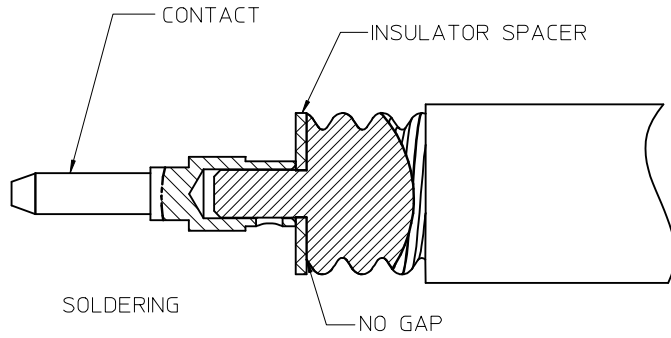

STEP 1

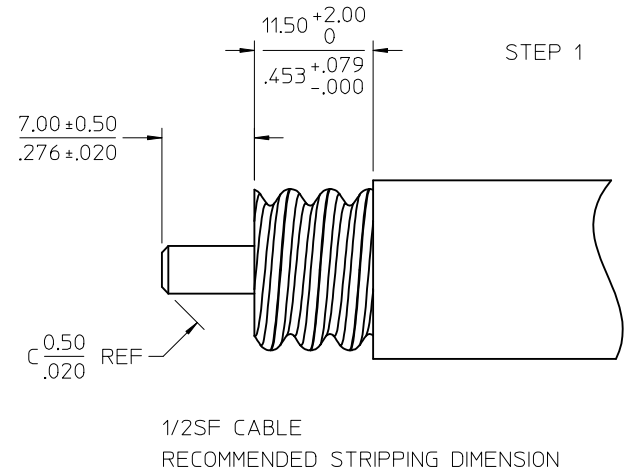

STEP 3

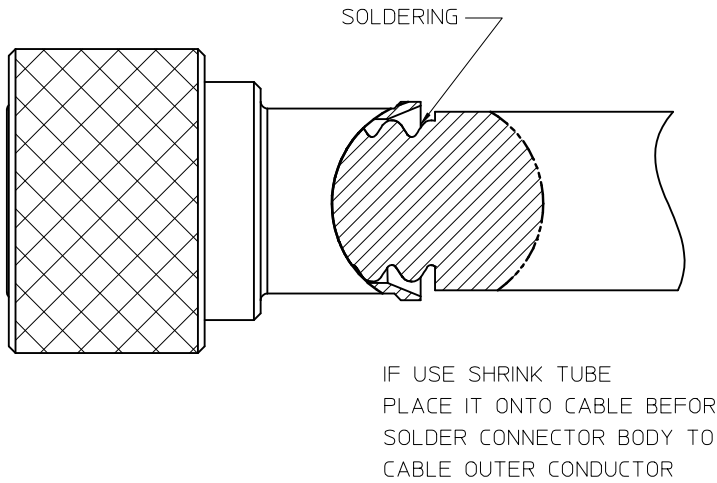

CHG: SEE SHEET 1 EC NO: URF2016-0691 DRWN:YHUANG11 2016/04/15 CHKD: APPR:MYE08 2016/04/20	QUALITY SYMBOLS ▽=0 ▽=0 ▽=0	GENERAL TOLERANCES (UNLESS SPECIFIED)		DIMENSION STYLE MM/IN	SCALE	DESIGN UNITS METRIC	THIRD ANGLE PROJECTION
		mm	INCH	DRAWN BY YHUANG11	DATE 2015/12/03	TITLE 4.3-10 PLUG, 50 OHM FOR 1/2SF CA, SOLDERING 4.3-10-PS,HAND-TIGHT	
A1	DESCRIPTION	4 PLACES ±	---	±	---	CHECKED BY MXU11	DATE 2015/12/03
		3 PLACES ±	---	±	---	APPROVED BY MYE08	DATE 2016/02/01
		2 PLACES ±	---	±	---	MATERIAL NO. SEE TABLE	
		1 PLACE ±	---	±	---	DOCUMENT NO. SD-73162-617	
		0 PLACE ±	---	±	---	SHEET NO. 2 OF 2	
		ANGULAR ± 2°		DRAFT WHERE APPLICABLE MUST REMAIN WITHIN DIMENSIONS		THIS DRAWING CONTAINS INFORMATION THAT IS PROPRIETARY TO MOLEX INCORPORATED AND SHOULD NOT BE USED WITHOUT WRITTEN PERMISSION	