



Chipsmall Limited consists of a professional team with an average of over 10 year of expertise in the distribution of electronic components. Based in Hongkong, we have already established firm and mutual-benefit business relationships with customers from,Europe,America and south Asia,supplying obsolete and hard-to-find components to meet their specific needs.

With the principle of “Quality Parts,Customers Priority,Honest Operation,and Considerate Service”,our business mainly focus on the distribution of electronic components. Line cards we deal with include Microchip,ALPS,ROHM,Xilinx,Pulse,ON,Everlight and Freescale. Main products comprise IC,Modules,Potentiometer,IC Socket,Relay,Connector.Our parts cover such applications as commercial,industrial, and automotives areas.

We are looking forward to setting up business relationship with you and hope to provide you with the best service and solution. Let us make a better world for our industry!



Contact us

Tel: +86-755-8981 8866 Fax: +86-755-8427 6832

Email & Skype: info@chipsmall.com Web: www.chipsmall.com

Address: A1208, Overseas Decoration Building, #122 Zhenhua RD., Futian, Shenzhen, China



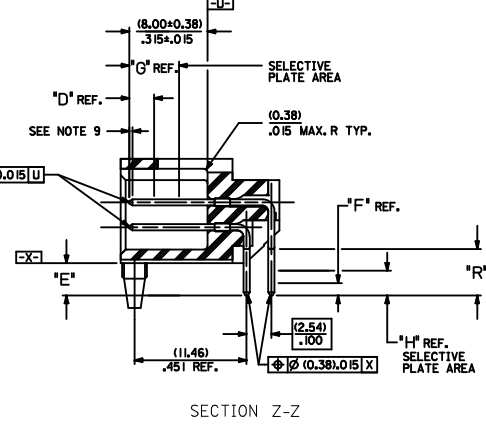
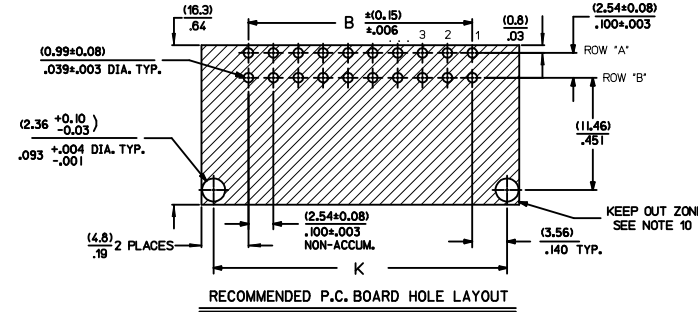
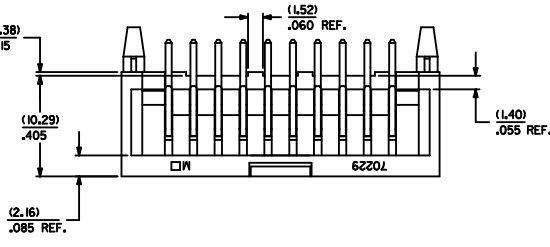
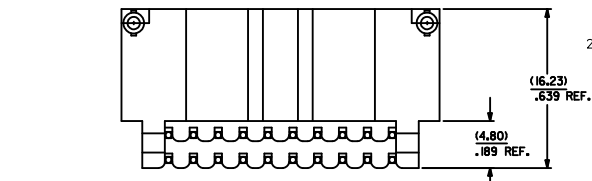
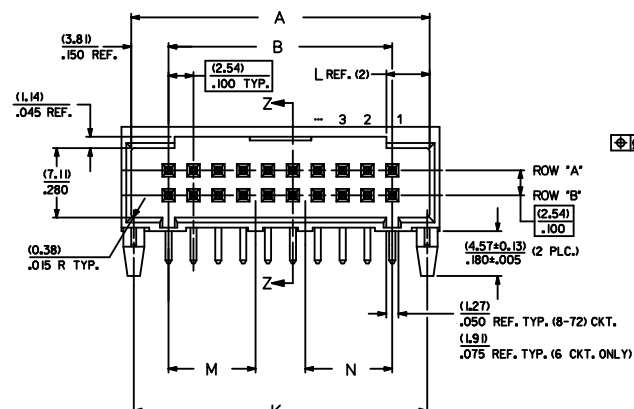
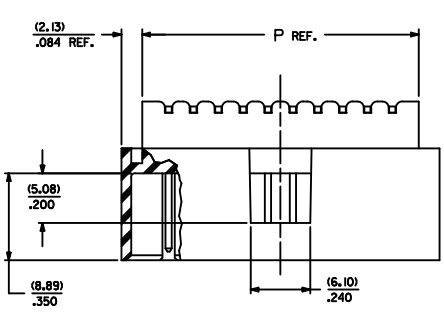

- NOTES
1. MATERIAL: SHROUDED WAFER: GLASS FILLED, LIQUID CRYSTAL POLYMER, COLOR: BLACK, UL94V-0
PINS: COPPER ALLOY
 2. FINISH:
TIN - 3.81 MICROMETERS/150 MICROINCHES MINIMUM TIN PLATE OVER NICKEL UNDERPLATE OVERALL
15 GOLD - 0.38 MICROMETERS/15 MICROINCHES MINIMUM GOLD PLATE IN SELECT AREA
1.91 MICROMETERS/75 MICROINCHES MINIMUM TIN PLATE IN SELECT AREA OVER NICKEL UNDERPLATE OVERALL
30 GOLD - 0.76 MICROMETERS/30 MICROINCHES MINIMUM GOLD PLATE IN SELECT AREA
1.91 MICROMETERS/75 MICROINCHES MINIMUM TIN PLATE IN SELECT AREA OVER NICKEL UNDERPLATE OVERALL
50 GOLD - 1.27 MICROMETERS/50 MICROINCHES MINIMUM GOLD PLATE IN SELECT AREA
1.91 MICROMETERS/75 MICROINCHES MINIMUM TIN PLATE IN SELECT AREA OVER NICKEL UNDERPLATE OVERALL
 3. PRODUCT SPECIFICATION: PS-74164-0001
 4. PACKAGING INFORMATION: SEE CHART
 5. 20 CIRCUIT SIZE SHOWN FOR ILLUSTRATION PURPOSES.
 6. PIN PUSHOUT FORCE: (17.79 N) 4 LBS.
 7. PINS MUST MEET SOLDERABILITY SPEC. MIL-STD-202 METHOD 208B.
 8. FOR CHARTED DIMENSIONS AND ASSEMBLY N.O.S NOT SHOWN ON THIS SHEET - SEE SHEET 2.
 9. ROW TO ROW PIN HEIGHT VARIATION MUST NOT EXCEED (0.25) .010 IN.
 10. NO FEATURES WHICH RISE ABOVE THE PCB SURFACE ALLOWED IN THIS AREA
 11. THIS PART CONFORMS TO CLASS B REQUIREMENTS OF COSMETIC SPECIFICATION PS-45499-002.

CKT.	DIM. "A"	DIM. "B"	DIM. "K"	DIM. "L"	DIM. "M"	DIM. "N"	DIM. "P"
06	(12.70) .500	(5.08) .200	(12.19) .480	(3.30) .130			(10.46) .412
08	(15.24) .600	(7.62) .300	(14.73) .580	(4.42) .174			(13.00) .512
10	(17.78) .700	(10.16) .400	(17.27) .680	(4.42) .174			(15.54) .612
12	(20.32) .800	(12.70) .500	(19.81) .780	(4.42) .174			(18.08) .712
14	(22.86) .900	(15.24) .600	(22.35) .880	(4.42) .174			(20.62) .812
16	(25.40) 1.000	(17.78) .700	(24.89) .980	(4.42) .174			(23.16) .912
18	(27.94) 1.100	(20.32) .800	(27.43) 1.080	(4.42) .174			(25.70) 1.012
20	(30.48) 1.200	(22.86) .900	(29.97) 1.180	(4.42) .174			(28.24) 1.112
22	(33.02) 1.300	(25.40) 1.000	(32.51) 1.280	(4.42) .174			(30.78) 1.212
24	(35.56) 1.400	(27.94) 1.100	(35.05) 1.380	(4.42) .174	(16.64) .655		(33.32) 1.312
26	(38.10) 1.500	(30.48) 1.200	(37.59) 1.480	(4.42) .174	(16.64) .655		(35.86) 1.412
28	(40.64) 1.600	(33.02) 1.300	(40.13) 1.580	(4.42) .174	(16.64) .655		(38.40) 1.512
30	(43.18) 1.700	(35.56) 1.400	(42.67) 1.680	(4.42) .174	(16.64) .655		(40.94) 1.612
32	(45.72) 1.800	(38.10) 1.500	(45.21) 1.780	(4.42) .174	(16.64) .655		(43.48) 1.712
34	(48.26) 1.900	(40.64) 1.600	(47.75) 1.880	(4.42) .174	(16.64) .655	(16.76) .660	(46.02) 1.812
36	(50.80) 2.000	(43.18) 1.700	(50.29) 1.980	(4.42) .174	(16.64) .655	(16.76) .660	(48.56) 1.912
38	(53.34) 2.100	(45.72) 1.800	(52.83) 2.080	(4.42) .174	(16.64) .655	(16.76) .660	(51.10) 2.012
40	(55.88) 2.200	(48.26) 1.900	(55.37) 2.180	(4.42) .174	(16.64) .655	(16.76) .660	(53.64) 2.112
42	(58.42) 2.300	(50.80) 2.000	(57.91) 2.280	(4.42) .174	(16.64) .655	(16.76) .660	(56.18) 2.212
44	(60.96) 2.400	(53.34) 2.100	(60.45) 2.380	(4.42) .174	(19.05) .750	(16.76) .660	(58.72) 2.312
46	(63.50) 2.500	(55.88) 2.200	(62.99) 2.480	(4.42) .174	(19.05) .750	(16.76) .660	(61.26) 2.412
48	(66.04) 2.600	(58.42) 2.300	(65.53) 2.580	(4.42) .174	(19.05) .750	(16.76) .660	(63.80) 2.512
50	(68.58) 2.700	(60.96) 2.400	(68.07) 2.680	(4.42) .174	(19.05) .750	(16.76) .660	(66.34) 2.612
52	(71.12) 2.800	(63.50) 2.500	(70.61) 2.780	(4.42) .174	(19.05) .750	(16.76) .660	(68.88) 2.712
54	(73.66) 2.900	(66.04) 2.600	(73.15) 2.880	(4.42) .174	(21.59) .850	(16.84) .660	(71.42) 2.812
56	(76.20) 3.000	(68.58) 2.700	(75.69) 2.980	(4.42) .174	(21.59) .850	(16.84) .660	(73.96) 2.912
58	(78.74) 3.100	(71.12) 2.800	(78.23) 3.080	(4.42) .174	(21.81) .860	(16.76) .660	(76.50) 3.012
60	(81.28) 3.200	(73.66) 2.900	(80.77) 3.180	(4.42) .174	(21.81) .860	(16.76) .660	(79.04) 3.112
62	(83.82) 3.300	(76.20) 3.000	(83.31) 3.280	(4.42) .174	(21.81) .860	(16.76) .660	(81.58) 3.212
64	(86.36) 3.400	(78.74) 3.100	(85.85) 3.380	(4.42) .174	(21.81) .860	(16.76) .660	(84.12) 3.312
66	(88.90) 3.500	(81.28) 3.200	(88.39) 3.480	(4.42) .174	(21.81) .860	(16.76) .660	(86.66) 3.412
68	(91.44) 3.600	(83.82) 3.300	(90.93) 3.580	(4.42) .174	(21.81) .860	(16.76) .660	(89.20) 3.512
70	(93.98) 3.700	(86.36) 3.400	(93.47) 3.680	(4.42) .174	(21.81) .860	(16.76) .660	(91.74) 3.612
72	(96.52) 3.800	(88.90) 3.500	(96.01) 3.780	(4.42) .174	(21.81) .860	(16.76) .660	(94.28) 3.712

MODIFY PIN MATERIAL IEC NO: UCP2011-0305 DRAWN BY: MIBARRA 2010/08/25 CHKD BY: CHOKIMORAN 2010/10/06 APPR: SMILLER	QUALITY SYMBOLS ∇=0 ∇=0 ∇=0	GENERAL TOLERANCES (UNLESS SPECIFIED) mm INCH 4 PLACES ± --- ± --- 3 PLACES ± --- ± .010 2 PLACES ± 0.25 ± .014 1 PLACE ± 0.36 ± --- ANGULAR ±1/2°	DIMENSION STYLE MM/IN SCALE 4:1 DESIGN UNITS INCH THIRD ANGLE PROJECTION
		DRAFT WHERE APPLICABLE MUST REMAIN WITHIN DIMENSIONS	DRAWN BY: MIBARRA 2009/03/30 CHECKED BY: BBARKER 2009/03/30 APPROVED BY: SMILLER 2009/03/30 DATE: 2009/03/30

ITEM NUMBER 74164	E REF	R REF	PLATING FINISH	CONNECTOR END PLATING			PC BOARD END PLATING			INFORMATION PK-70873	VOIDED CIRCUITS	
				TYPE	G LENGTH	D MEAS.	TYPE	H LENGTH	F MEAS.			
-0006-0072	3.30 .130	4.75 .187	15 GOLD	GOLD	5.08 .200	2.54 .100		TIN	3.81 .150	2.54 .100	0019	
-0106-0172	3.30 .130	4.75 .187	TIN	TIN		2.54 .100		TIN		2.54 .100	0019	
-0206-0272	3.30 .130	4.75 .187	50 GOLD	GOLD	5.08 .200	2.54 .100		TIN	3.81 .150	2.54 .100	0019	
-0306-0372	3.30 .130	4.75 .187	30 GOLD	GOLD	5.08 .200	2.54 .100		TIN	3.81 .150	2.54 .100	0019	
-3001	3.30 .130	4.75 .187	15 GOLD	GOLD	5.08 .200	2.54 .100		TIN	3.81 .150	2.54 .100	0019	A14, A15, A16, A18, A19, A22, A23 B14, B15, B16, B18, B19, B22, B23

NO. OF CKTS	ITEM NUMBER	ITEM NUMBER	ITEM NUMBER	ITEM NUMBER	ITEM NUMBER	ITEM NUMBER	ITEM NUMBER
6	74164-0006	74164-0106	74164-0206	74164-0306			
8	74164-0008	74164-0108	74164-0208	74164-0308			
10	74164-0010	74164-0110	74164-0210	74164-0310			
12	74164-0012	74164-0112	74164-0212	74164-0312			
14	74164-0014	74164-0114	74164-0214	74164-0314			
16	74164-0016	74164-0116	74164-0216	74164-0316			
18	74164-0018	74164-0118	74164-0218	74164-0318			
20	74164-0020	74164-0120	74164-0220	74164-0320			
22	74164-0022	74164-0122	74164-0222	74164-0322			
24	74164-0024	74164-0124	74164-0224	74164-0324			
26	74164-0026	74164-0126	74164-0226	74164-0326			
28	74164-0028	74164-0128	74164-0228	74164-0328			
30	74164-0030	74164-0130	74164-0230	74164-0330			
32	74164-0032	74164-0132	74164-0232	74164-0332			
34	74164-0034	74164-0134	74164-0234	74164-0334			
36	74164-0036	74164-0136	74164-0236	74164-0336			
38	74164-0038	74164-0138	74164-0238	74164-0338			
40	74164-0040	74164-0140	74164-0240	74164-0340			
42	74164-0042	74164-0142	74164-0242	74164-0342			
44	74164-0044	74164-0144	74164-0244	74164-0344			
46	74164-0046	74164-0146	74164-0246	74164-0346			
48	74164-0048	74164-0148	74164-0248	74164-0348			
50	74164-0050	74164-0150	74164-0250	74164-0350		74164-3001	
52	74164-0052	74164-0152	74164-0252	74164-0352			
54	74164-0054	74164-0154	74164-0254	74164-0354			
56	74164-0056	74164-0156	74164-0256	74164-0356			
58	74164-0058	74164-0158	74164-0258	74164-0358			
60	74164-0060	74164-0160	74164-0260	74164-0360			
62	74164-0062	74164-0162	74164-0262	74164-0362			
64	74164-0064	74164-0164	74164-0264	74164-0364			
66	74164-0066	74164-0166	74164-0266	74164-0366			
68	74164-0068	74164-0168	74164-0268	74164-0368			
70	74164-0070	74164-0170	74164-0270	74164-0370			
72	74164-0072	74164-0172	74164-0272	74164-0372			

SEE SHEET 1 IEC NO. UCF2011-0305 DRAWN BY: MIBARRA 2010/08/25 CHECKED BY: CHYO MORGAN 2010/10/06 APPR: SMILLER	QUALITY SYMBOLS ▽=0 ▽=0 ▽=0	GENERAL TOLERANCES (UNLESS SPECIFIED) mm INCH		DIMENSION STYLE MM/IN	SCALE 1:1	DESIGN UNITS INCH	THIRD ANGLE PROJECTION		
		4 PLACES ±.010 ±.010 3 PLACES ±.025 ±.014 2 PLACES ±.036 ±.014 1 PLACE ±.036 ±.014	DRAWN BY: MIBARRA 2009/03/30 CHECKED BY: BBARKER 2009/03/30 APPROVED BY: SMILLER 2009/03/30	TITLE SALES ASSEMBLY RIGHT ANGLE SHROUDED W/PC BOARD STAB PEGS		MATERIAL NO. SEE TABLE DOCUMENT NO. SD-74164-001		SHEET NO. 2 OF 2	
		DRAFT WHERE APPLICABLE MUST REMAIN WITHIN DIMENSIONS		THIS DRAWING CONTAINS INFORMATION THAT IS PROPRIETARY TO MOLEX INCORPORATED AND SHOULD NOT BE USED WITHOUT WRITTEN PERMISSION					
		MOLEX INCORPORATED							