



Chipsmall Limited consists of a professional team with an average of over 10 year of expertise in the distribution of electronic components. Based in Hongkong, we have already established firm and mutual-benefit business relationships with customers from,Europe,America and south Asia,supplying obsolete and hard-to-find components to meet their specific needs.

With the principle of “Quality Parts,Customers Priority,Honest Operation,and Considerate Service”,our business mainly focus on the distribution of electronic components. Line cards we deal with include Microchip,ALPS,ROHM,Xilinx,Pulse,ON,Everlight and Freescale. Main products comprise IC,Modules,Potentiometer,IC Socket,Relay,Connector.Our parts cover such applications as commercial,industrial, and automotives areas.

We are looking forward to setting up business relationship with you and hope to provide you with the best service and solution. Let us make a better world for our industry!



## Contact us

Tel: +86-755-8981 8866 Fax: +86-755-8427 6832

Email & Skype: info@chipsmall.com Web: www.chipsmall.com

Address: A1208, Overseas Decoration Building, #122 Zhenhua RD., Futian, Shenzhen, China



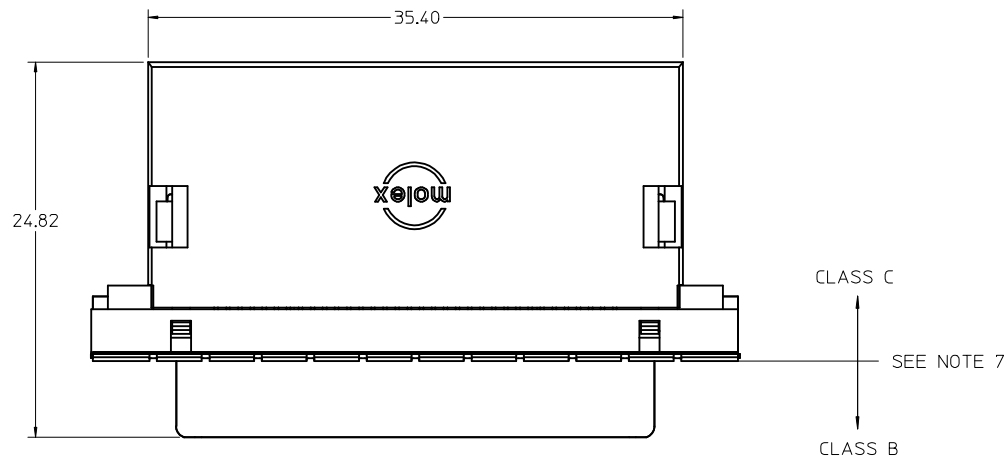

NOTES:

1. MATERIALS:  
HOUSING, COVER, AND TAIL ALIGNER: HIGH TEMPERATURE THERMOPLASTIC, UL94, V-0 RATED, COLOR: BLACK  
TERMINAL: PHOSPHOR BRONZE ALLOY  
BRACKET: BRASS  
SHELL: STEEL  
INSERT: BRASS
2. FINISHES:  
TERMINAL: 0.05-0.25 MICROMETERS GOLD FLASH IN CRITICAL AREA OVER 0.75 MICROMETERS MINIMUM PALLADIUM NICKEL IN CRITICAL AREA, 1.87 MICROMETERS MINIMUM TIN IN SOLDER TAIL AREA, ALL OVER NICKEL.  
BRACKET: 5.0 MICROMETERS MINIMUM BRIGHT TIN.  
SHIELD: 3.81 MICROMETERS MINIMUM BRIGHT TIN OVER 1.27 MICROMETERS MINIMUM NICKEL OVER COPPER FLASH (OPTIONAL).  
INSERT: 2.54 MICROMETERS MINIMUM NICKEL.
3. PRODUCT SPECIFICATION: PS-71425-9999.
4. PACKAGING SPECIFICATION: TRAY PACK PER PK-74337-001.
5. APPLICABLE STANDARDS: EIA-700A0AF AND SFF-8441.
6. DATE CODE: YR/WK PER EIA-476-A.
7. PRODUCT COMPLIES WITH COSMETIC SPECIFICATION PS-45499-002. SEE FIGURE AT LEFT FOR SURFACE CLASSIFICATIONS.
8. TORQUE TO INSTALL SCREWLOCKS INTO THREADED INSERTS: 0.34 Nm MAXIMUM.

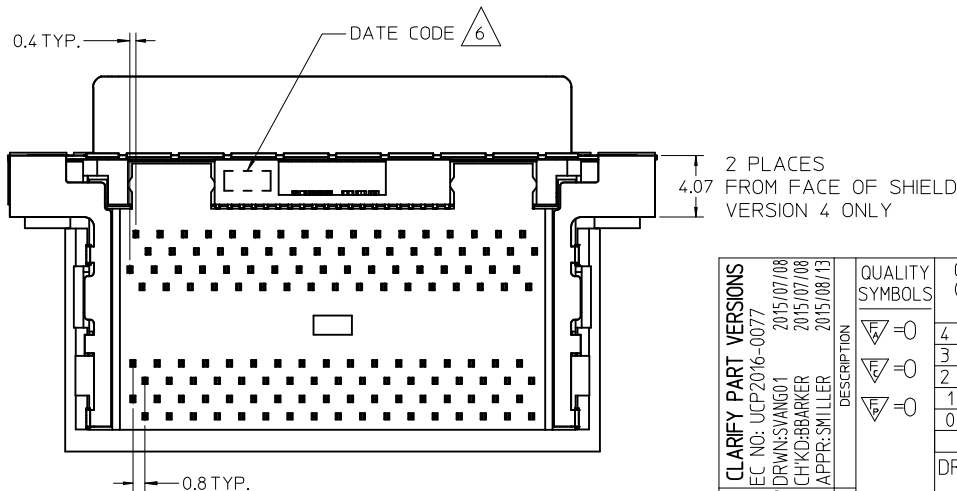
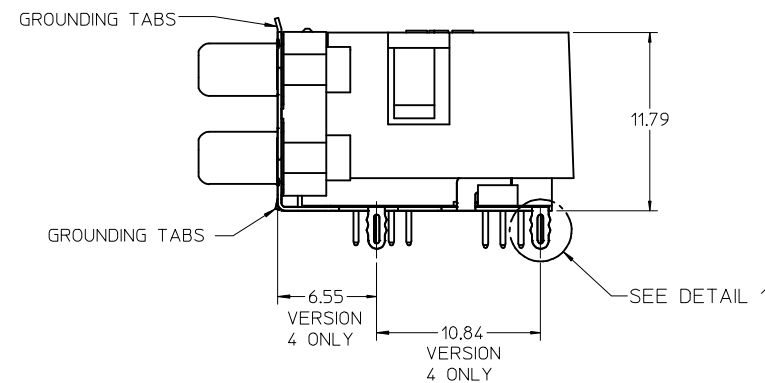
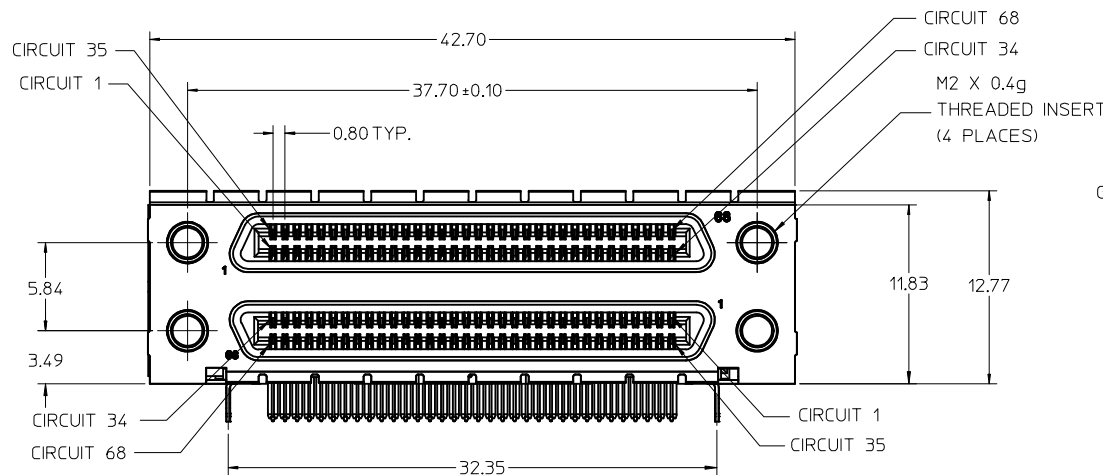

VERSION 4, WITH COVER SHOWN ON THIS SHEET

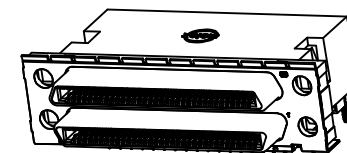

<b>CLARIFY PART VERSIONS</b> EC NO: UCP2016-0077 DRWNS:VANG01 2015/07/08 CHKD:BBARKER 2015/07/08 APPR:SMILLER 2015/08/13 REV S	QUALITY SYMBOLS ▽=0 ▽=0 ▽=0	GENERAL TOLERANCES (UNLESS SPECIFIED) <table border="1"> <thead> <tr> <th></th> <th>mm</th> <th>INCH</th> </tr> </thead> <tbody> <tr> <td>4 PLACES</td> <td>± ---</td> <td>± ---</td> </tr> <tr> <td>3 PLACES</td> <td>± ---</td> <td>± ---</td> </tr> <tr> <td>2 PLACES</td> <td>± 0.13</td> <td>± ---</td> </tr> <tr> <td>1 PLACE</td> <td>± 0.25</td> <td>± ---</td> </tr> <tr> <td>0 PLACE</td> <td>±</td> <td>±</td> </tr> </tbody> </table>		mm	INCH	4 PLACES	± ---	± ---	3 PLACES	± ---	± ---	2 PLACES	± 0.13	± ---	1 PLACE	± 0.25	± ---	0 PLACE	±	±	DIMENSION STYLE <b>MM ONLY</b> DRAWN BY DATE SSAMPSON 05.08.2001 CHECKED BY DATE MBANAK IS 05.08.2001 APPROVED BY DATE MBANAK IS 05.08.2001	SCALE <b>3:1</b> DESIGN UNITS METRIC THIRD ANGLE PROJECTION	TITLE <b>VHDCI STACKED ASSEMBLY</b>
		mm	INCH																				
	4 PLACES	± ---	± ---																				
	3 PLACES	± ---	± ---																				
	2 PLACES	± 0.13	± ---																				
1 PLACE	± 0.25	± ---																					
0 PLACE	±	±																					
MATERIAL NO. <b>SEE TABLE</b>	DOCUMENT NO. <b>SD-74337-014</b>	SHEET NO. <b>1 OF 4</b>																					
DRAFT WHERE APPLICABLE MUST REMAIN WITHIN DIMENSIONS			THIS DRAWING CONTAINS INFORMATION THAT IS PROPRIETARY TO MOLEX INCORPORATED AND SHOULD NOT BE USED WITHOUT WRITTEN PERMISSION																				

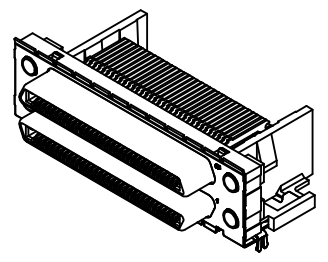
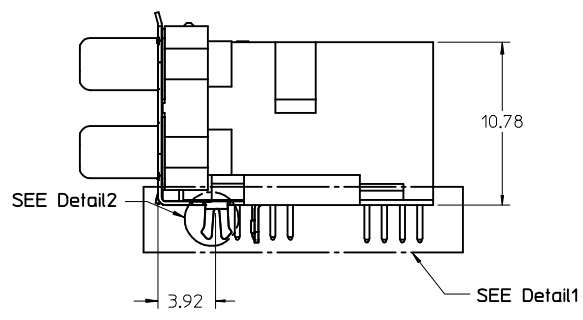
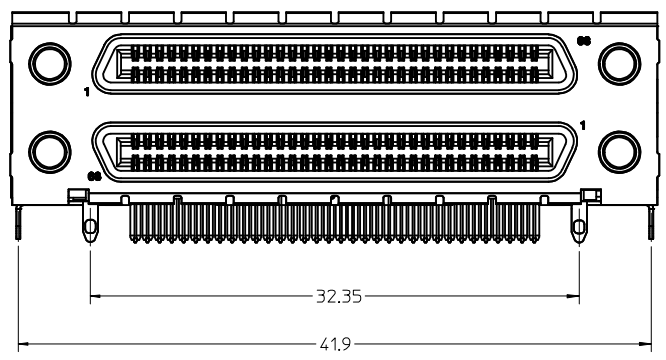
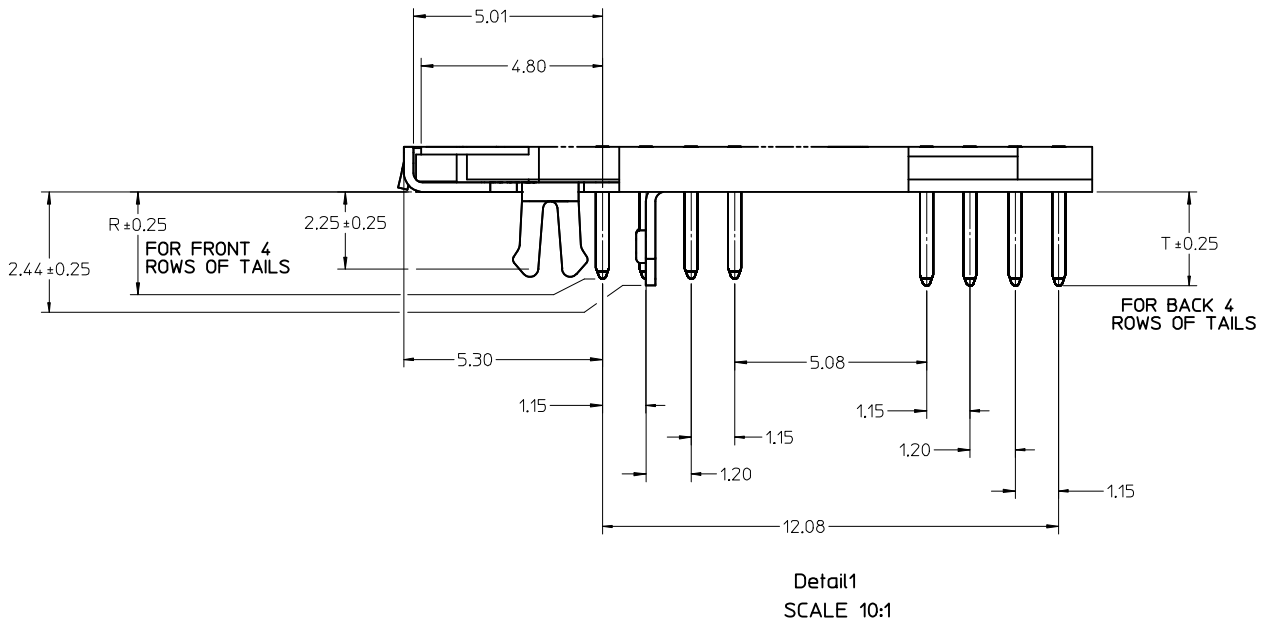
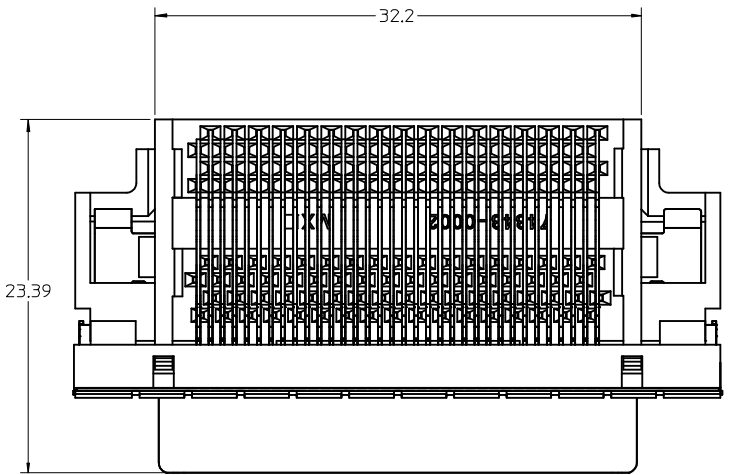

VERSION 1 WITHOUT COVER  
SHOWN ON THIS SHEET

NOTE: DIMENSION SHOWN ON SHEET 1  
APPLY EXCEPT AS NOTED.

<b>SEE SHEET 1</b> EC NO: UCP2016-0077 DRWNS:VANG01 2015/07/08 CHKD:BBARKER 2015/07/08 APPR:SMILLER 2015/08/13	QUALITY SYMBOLS 	GENERAL TOLERANCES (UNLESS SPECIFIED) <table border="1"> <thead> <tr> <th></th> <th>mm</th> <th>INCH</th> </tr> </thead> <tbody> <tr> <td>4 PLACES</td> <td>± ---</td> <td>± ---</td> </tr> <tr> <td>3 PLACES</td> <td>± ---</td> <td>± ---</td> </tr> <tr> <td>2 PLACES</td> <td>± 0.13</td> <td>± ---</td> </tr> <tr> <td>1 PLACE</td> <td>± 0.25</td> <td>± ---</td> </tr> <tr> <td>0 PLACE</td> <td>±</td> <td>±</td> </tr> </tbody> </table>		mm	INCH	4 PLACES	± ---	± ---	3 PLACES	± ---	± ---	2 PLACES	± 0.13	± ---	1 PLACE	± 0.25	± ---	0 PLACE	±	±	DIMENSION STYLE <b>MM ONLY</b> DRAWN BY: SSAMPSON DATE: 05.08.2001 CHECKED BY: MBANAKIS DATE: 05.08.2001 APPROVED BY: MBANAKIS DATE: 05.08.2001	SCALE: 4:1 DESIGN UNITS: METRIC THIRD ANGLE PROJECTION	TITLE: VHCI STACKED ASSEMBLY
		mm	INCH																				
	4 PLACES	± ---	± ---																				
	3 PLACES	± ---	± ---																				
2 PLACES	± 0.13	± ---																					
1 PLACE	± 0.25	± ---																					
0 PLACE	±	±																					
DRAFT WHERE APPLICABLE MUST REMAIN WITHIN DIMENSIONS	ANGULAR ± 1°	MATERIAL NO.	DOCUMENT NO.	SHEET NO.	THIS DRAWING CONTAINS INFORMATION THAT IS PROPRIETARY TO MOLEX INCORPORATED AND SHOULD NOT BE USED WITHOUT WRITTEN PERMISSION																		
SEE TABLE	SEE TABLE	SD-74337-014	2 OF 4																				

### VERSION 1 PART NUMBERS

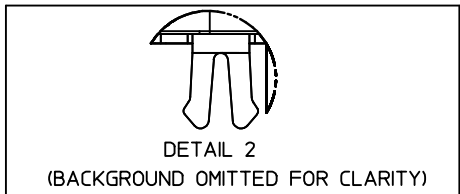

DETAIL 2  
(BACKGROUND OMITTED FOR CLARITY)

BOARD RETENTION: SNAP FIT

PCB THICKNESS	COVER	R DIM.	T DIM.	INCLUDES LOOSE PACKED SCREWLOCKS 71433-0002 SEE DRAWING SD-71433-005	GROUNDING TABS	PART NUMBER
1.60±0.16	YES	2.30	2.48	NO	YES	74337-0011
1.60±0.16	YES	2.08		NO	YES	74337-0012
1.60±0.16	NO	2.30	2.48	NO	YES	74337-0015
1.60±0.16	NO	2.08		NO	YES	74337-0016
1.60±0.16	YES	2.30	2.48	YES	YES	74337-0037
1.60±0.16	YES	2.08		YES	YES	74337-0038
1.60±0.16	NO	2.30	2.48	YES	YES	74337-0039
1.60±0.16	NO	2.08		YES	YES	74337-0040
2.36±0.16	YES	3.44	3.62	NO	YES	74337-0070
2.36±0.16	NO	3.44	3.62	NO	YES	74337-0071
2.36±0.16	YES	3.44	3.62	YES	YES	74337-0072
2.36±0.16	NO	3.44	3.62	YES	YES	74337-0073
1.60±0.16	YES	2.08		INSTALLED ON PART	YES	74337-1038

### VERSION 4 PART NUMBERS

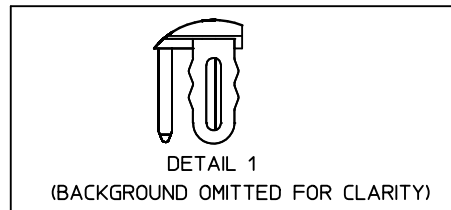

DETAIL 1  
(BACKGROUND OMITTED FOR CLARITY)

BOARD RETENTION: PRESS FIT

PCB THICKNESS	COVER	R DIM.	T DIM.	INCLUDES LOOSE PACKED SCREWLOCKS 71433-0002 SEE DRAWING SD-71433-005	GROUNDING TABS	PART NUMBER
1.60±0.16	YES	2.30	2.48	NO	YES	74337-0050
1.60±0.16	YES	2.08		NO	NO	74337-0051
1.60±0.16	NO	2.30	2.48	NO	YES	74337-0060
1.60±0.16	NO	2.08		NO	YES	74337-0061
1.60±0.16	YES	2.08		NO	YES	74337-0066
1.60±0.16	YES	2.30	2.48	YES	YES	74337-0053
1.60±0.16	YES	2.08		YES	YES	74337-0054
1.60±0.16	NO	2.30	2.48	YES	YES	74337-0063
1.60±0.16	NO	2.08		YES	YES	74337-0064
2.36±0.16	YES	3.44	3.62	NO	YES	74337-0052
2.36±0.16	NO	3.44	3.62	NO	YES	74337-0062
2.36±0.16	YES	3.44	3.62	YES	YES	74337-0055
2.36±0.16	NO	3.44	3.62	YES	YES	74337-0065
1.60±0.16	YES	2.08		INSTALLED ON PART	YES	74337-1054

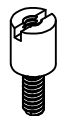

OPTIONAL SCREWLOCK  
71433-0002

SEE SHEET 1 EC NO: UCP2016-0077 DRWNSVANG01 2015/07/08 CHKD:BBARKER 2015/07/08 APPR:SMILLER 2015/08/13	QUALITY SYMBOLS ▽=0 ▽=0 ▽=0	GENERAL TOLERANCES (UNLESS SPECIFIED) <table border="1"> <tr><th colspan="2">mm</th><th>INCH</th></tr> <tr><td>4 PLACES ±</td><td>---</td><td>±---</td></tr> <tr><td>3 PLACES ±</td><td>---</td><td>±---</td></tr> <tr><td>2 PLACES ±</td><td>0.13</td><td>±---</td></tr> <tr><td>1 PLACE ±</td><td>0.25</td><td>±---</td></tr> <tr><td>0 PLACE ±</td><td></td><td>±</td></tr> </table>	mm		INCH	4 PLACES ±	---	±---	3 PLACES ±	---	±---	2 PLACES ±	0.13	±---	1 PLACE ±	0.25	±---	0 PLACE ±		±	DIMENSION STYLE <b>MM ONLY</b> DRAWN BY DATE SSAMPSON 05.08.2001 CHECKED BY DATE MBANAK I S 05.08.2001 APPROVED BY DATE MBANAK I S 05.08.2001	SCALE <b>3:1</b> DESIGN UNITS <b>METRIC</b>	THIRD ANGLE PROJECTION
	mm		INCH																				
	4 PLACES ±	---	±---																				
	3 PLACES ±	---	±---																				
	2 PLACES ±	0.13	±---																				
1 PLACE ±	0.25	±---																					
0 PLACE ±		±																					
DRAFT WHERE APPLICABLE MUST REMAIN WITHIN DIMENSIONS		MATERIAL NO. <b>SEE TABLE</b>	TITLE <b>VHDCI STACKED ASSEMBLY</b>																				
		ANGLAR ± 1 °	DOCUMENT NO. <b>SD-74337-014</b>																				
		SIZE THIS DRAWING CONTAINS INFORMATION THAT IS PROPRIETARY TO MOLEX INCORPORATED AND SHOULD NOT BE USED WITHOUT WRITTEN PERMISSION	SHEET NO. <b>3 OF 4</b>																				
			MOLEX																				

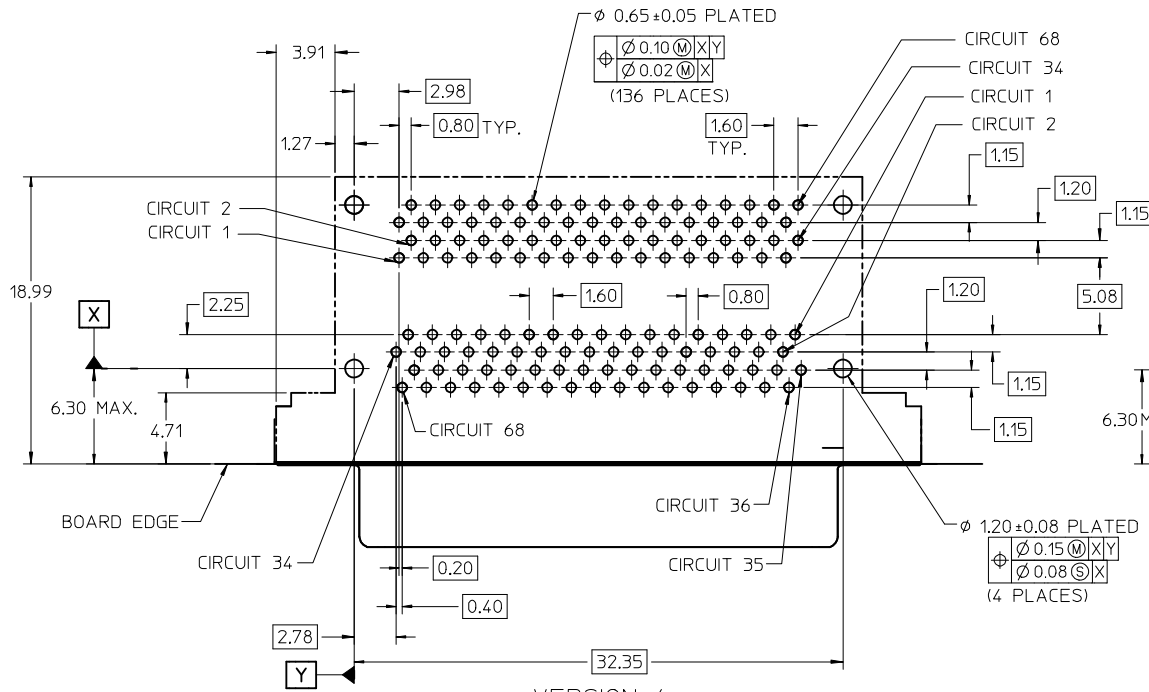

VERSION 4  
RECOMMENDED PCB LAYOUT  
COMPONENT SIDE SHOWN

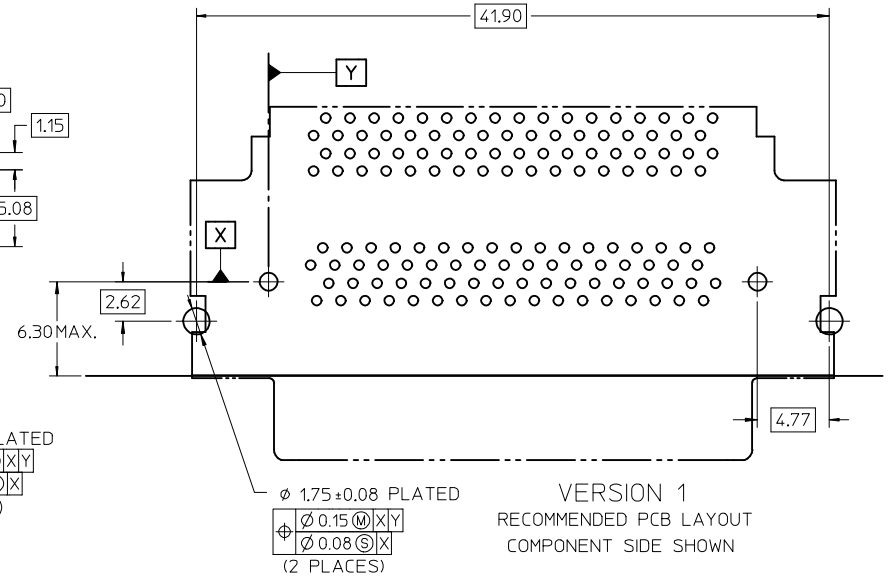

VERSION 1  
RECOMMENDED PCB LAYOUT  
COMPONENT SIDE SHOWN  
SAME AS VERSION 4 EXCEPT AS SHOWN

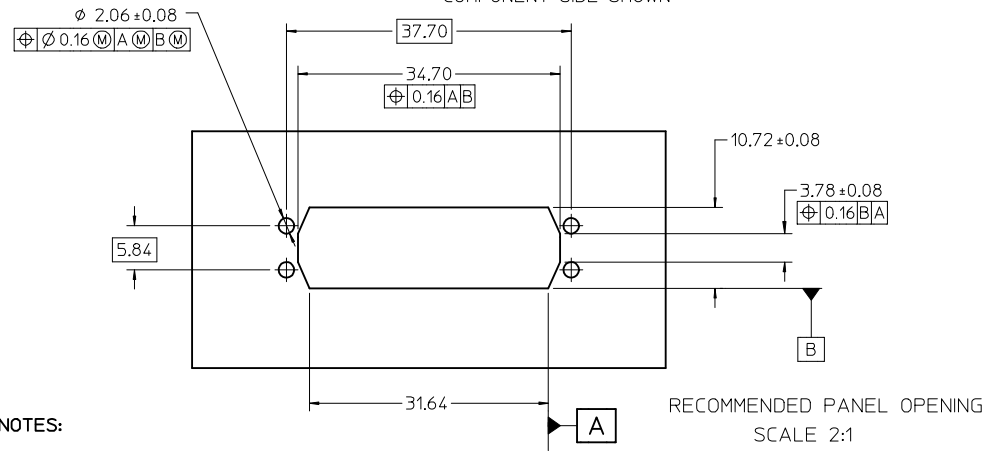

RECOMMENDED PANEL OPENING  
SCALE 2:1

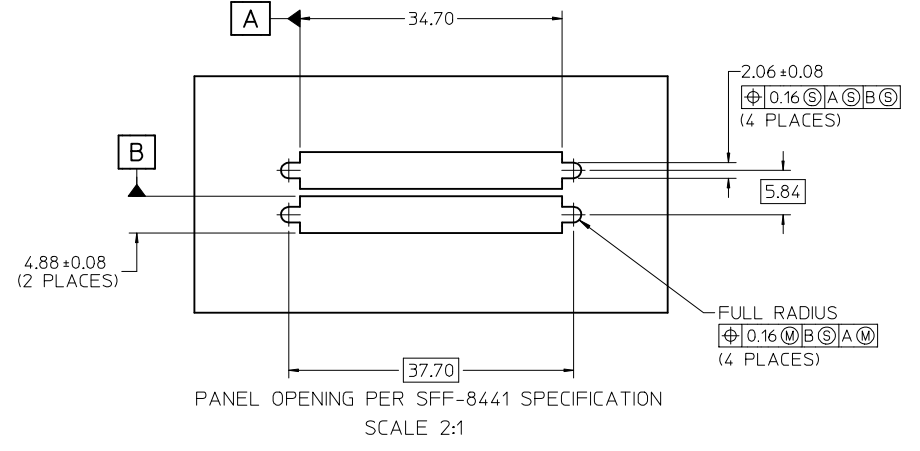

PANEL OPENING PER SFF-8441 SPECIFICATION  
SCALE 2:1

NOTES:

1. FOR FULL MATE WITH PLUG, PANEL THICKNESS SHOULD NOT EXCEED 1.0mm.

FUNCTIONAL MATING WITH MOLEX PLUG CAN STILL BE MAINTAINED WITH PANELS AS THICK AS 2.5mm (BUT PLUG AND RECEPTACLE WILL NOT BE FULLY MATED).

2. GUIDELINES FOR CHOOSING A MOLEX SCREWLOCK:

PANEL THICKNESS	RECOMMENDED SCREWLOCK
LESS THAN OR EQUAL TO 1.00 MM	71433-0002
1.01 TO 2.15 MM	71433-0010

<b>SEE SHEET 1</b> EC NO: UCP2016-0077 DRWNS:VANG01 2015/07/08 CHKD:BBARKER 2015/07/08 APPR:SMILLER 2015/08/13	QUALITY SYMBOLS $\nabla = 0$ $\nabla = 0$ $\nabla = 0$	GENERAL TOLERANCES (UNLESS SPECIFIED) <table border="1"> <thead> <tr> <th></th> <th>mm</th> <th>INCH</th> </tr> </thead> <tbody> <tr> <td>4 PLACES</td> <td><math>\pm 0.13</math></td> <td><math>\pm 0.005</math></td> </tr> <tr> <td>3 PLACES</td> <td><math>\pm 0.25</math></td> <td><math>\pm 0.010</math></td> </tr> <tr> <td>2 PLACES</td> <td><math>\pm 0.50</math></td> <td><math>\pm 0.020</math></td> </tr> <tr> <td>1 PLACE</td> <td><math>\pm 1.00</math></td> <td><math>\pm 0.040</math></td> </tr> <tr> <td>0 PLACE</td> <td><math>\pm 2.00</math></td> <td><math>\pm 0.080</math></td> </tr> </tbody> </table>		mm	INCH	4 PLACES	$\pm 0.13$	$\pm 0.005$	3 PLACES	$\pm 0.25$	$\pm 0.010$	2 PLACES	$\pm 0.50$	$\pm 0.020$	1 PLACE	$\pm 1.00$	$\pm 0.040$	0 PLACE	$\pm 2.00$	$\pm 0.080$	DIMENSION STYLE <b>MM ONLY</b> DRAWN BY: SSAMPSON DATE: 05.08.2001 CHECKED BY: MBANAK IS DATE: 05.08.2001 APPROVED BY: MBANAK IS DATE: 05.08.2001	SCALE: 3:1 DESIGN UNITS: METRIC THIRD ANGLE PROJECTION	TITLE: VHDCI STACKED ASSEMBLY
		mm	INCH																				
	4 PLACES	$\pm 0.13$	$\pm 0.005$																				
	3 PLACES	$\pm 0.25$	$\pm 0.010$																				
2 PLACES	$\pm 0.50$	$\pm 0.020$																					
1 PLACE	$\pm 1.00$	$\pm 0.040$																					
0 PLACE	$\pm 2.00$	$\pm 0.080$																					
		ANGULAR $\pm 1^\circ$ DRAFT WHERE APPLICABLE MUST REMAIN WITHIN DIMENSIONS	MATERIAL NO.: <b>SEE TABLE</b>	DOCUMENT NO.: <b>SD-74337-014</b>	SHEET NO.: <b>4 OF 4</b>																		
			SIZE: C THIS DRAWING CONTAINS INFORMATION THAT IS PROPRIETARY TO MOLEX INCORPORATED AND SHOULD NOT BE USED WITHOUT WRITTEN PERMISSION																				