



Chipsmall Limited consists of a professional team with an average of over 10 year of expertise in the distribution of electronic components. Based in Hongkong, we have already established firm and mutual-benefit business relationships with customers from,Europe,America and south Asia,supplying obsolete and hard-to-find components to meet their specific needs.

With the principle of “Quality Parts,Customers Priority,Honest Operation,and Considerate Service”,our business mainly focus on the distribution of electronic components. Line cards we deal with include Microchip,ALPS,ROHM,Xilinx,Pulse,ON,Everlight and Freescale. Main products comprise IC,Modules,Potentiometer,IC Socket,Relay,Connector.Our parts cover such applications as commercial,industrial, and automotives areas.

We are looking forward to setting up business relationship with you and hope to provide you with the best service and solution. Let us make a better world for our industry!



## Contact us

Tel: +86-755-8981 8866 Fax: +86-755-8427 6832

Email & Skype: info@chipsmall.com Web: www.chipsmall.com

Address: A1208, Overseas Decoration Building, #122 Zhenhua RD., Futian, Shenzhen, China



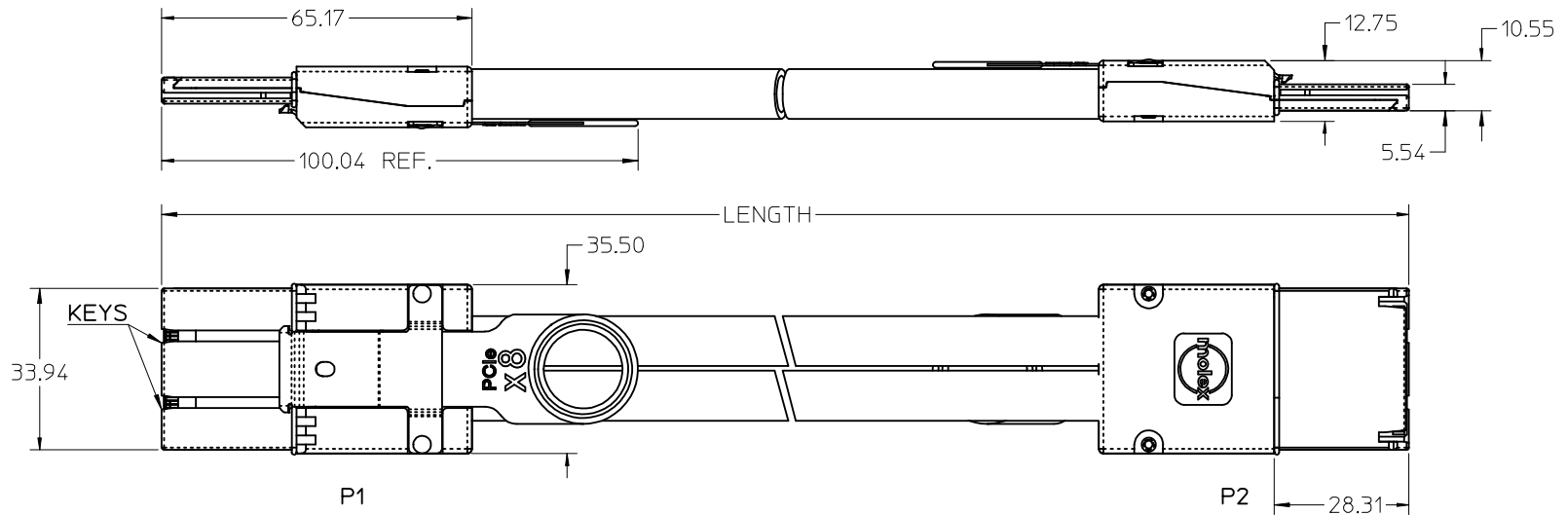

P/N	LENGTH	GAGE	TOLERANCE	JACKET RATING
74546-0801	1M	28	0.05M	VW1
74546-0802	2M	28	0.05M	VW1
74546-0803	3M	28	0.05M	VW1
74546-0804	4M	28	0.10M	VW1
74546-0805	5M	26	0.10M	CL2
74546-0806	6M	26	0.13M	CL2
74546-0807	7M	24	0.13M	CL2
74546-0808	8M Δ	24	0.13M	CL2
74546-0809	9M Δ	24	0.15M	CL2
74546-0810	10M Δ	24	0.15M	CL2
74546-0813	0.5M	28	0.03M	VW1

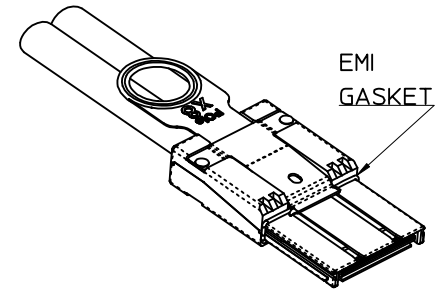

- NOTES:
- MATERIAL=
    - BACKSHELLS - ZINC DIECAST
    - PULL - NYLON
    - CABLE JACKET RATING - SEE TABLE.
  - LENGTH AND TOLERANCE - SEE TABLE
  - ELECTRICAL PERFORMANCE PER PCI EXPRESS EXTERNAL CABLING SPEC.
  - PLUG MATES TO RECEPTACLE 75586-0002, AND EMI GUIDE HOUSING ASSY. 74540-0100
  - ASSEMBLY IS TO BE RoHS COMPLIANT BY FEBRUARY 1, 2006.
- Δ. NOT COMPLIANT WITH INSERTION LOSS SPEC PER THR PCIe CABLING SPEC.

IPASS™ IS A TRADEMARK OF MOLEX

ENTER DESCRIPTION EC NO: USY2006-0481 DRWN:SNAYARRO 2006/06/29 CHKD:BREED 2006/06/29 APPR:DDOYE 2006/07/06	QUALITY SYMBOLS ▽=0 ▽=0	GENERAL TOLERANCES (UNLESS SPECIFIED)	DIMENSION STYLE	SCALE	DESIGN UNITS	THIRD ANGLE PROJECTION
		4 PLACES ± --- ± --- 3 PLACES ± --- ± --- 2 PLACES ± 0.13 ± --- 1 PLACE ± 0.25 ± ---	MM ONLY	1:1	METRIC	DRAWN BY DATE BREED 2004/11/09 CHECKED BY DATE DDOYE 2004/11/09 APPROVED BY DATE DDOYE 2004/11/09
		ANGULAR ±1/2°	TITLE I-PASS X8 CABLE ASSEMBLY GEN 1			
		DRAFT WHERE APPLICABLE MUST REMAIN WITHIN DIMENSIONS	MATERIAL NO. SEE TABLE MOLEX INCORPORATED DOCUMENT NO. SD-74546-800 SHEET NO. 1 OF 3			

GND	A1	▶	B1	GND
PETp0	A2	▶	B2	PERp0
PETn0	A3	▶	B3	PERn0
GND	A4	▶	B4	GND
PETp1	A5	▶	B5	PERp1
PETn1	A6	▶	B6	PERn1
GND	A7	▶	B7	GND
PETp2	A8	▶	B8	PERp2
PETn2	A9	▶	B9	PERn2
GND	A10	▶	B10	GND
PETp3	A11	▶	B11	PERp3
PETn3	A12	▶	B12	PERn3
GND	A13	▶	B13	GND
CREFCLK+	A14	▶	A14	CREFCLK+
CREFCLK-	A15	▶	A15	CREFCLK-
GND	A16	▶	A16	GND
NC	A17	▶	A17	NC
NC	A18	▶	A18	NC
SB_RTN	A19	▶	A19	SB_RTN
CPRSNT#	A20	▶	A20	CPRSNT#
CPWRON	A21	▶	A21	CPWRON
GND	A22	▶	B22	GND
PETp4	A23	▶	B23	PERp4
PETn4	A24	▶	B24	PERn4
GND	A25	▶	B25	GND
PETp5	A26	▶	B26	PERp5
PETn5	A27	▶	B27	PERn5
GND	A28	▶	B28	GND
PETp6	A29	▶	B29	PERp6
PETn6	A30	▶	B30	PERn6
GND	A31	▶	B31	GND
PETp7	A32	▶	B32	PERp7
PETn7	A33	▶	B33	PERn7
GND	A34	▶	B34	GND
GND	B1	▶	A1	GND
PERp0	B2	▶	A2	PETp0
PERn0	B3	▶	A3	PETn0
GND	B4	▶	A4	GND
PERp1	B5	▶	A5	PETp1
PERn1	B6	▶	A6	PETn1
GND	B7	▶	A7	GND
PERp2	B8	▶	A8	PETp2
PERn2	B9	▶	A9	PETn2
GND	B10	▶	A10	GND
PERp3	B11	▶	A11	PETp3
PERn3	B12	▶	A12	PETn3
GND	B13	▶	A13	GND
NC	B14	▶	B14	NC
NC	B15	▶	B15	NC
NC	B16	▶	B16	NC
NC	B17	▶	B17	NC
NC	B18	▶	B18	NC
NC	B19	▶	B19	NC
CWAKE#	B20	▶	B20	CWAKE#
CPRST#	B21	▶	B21	CPRST#
GND	B22	▶	A22	GND
PERp4	B23	▶	A23	PETp4
PERn4	B24	▶	A24	PETn4
GND	B25	▶	A25	GND
PERp5	B26	▶	A26	PETp5
PERn5	B27	▶	A27	PETn5
GND	B28	▶	A28	GND
PERp6	B29	▶	A29	PETp6
PERn6	B30	▶	A30	PETn6
GND	B31	▶	A31	GND
PERp7	B32	▶	A32	PETp7
PERn7	B33	▶	A33	PETn7
GND	B34	▶	A34	GND

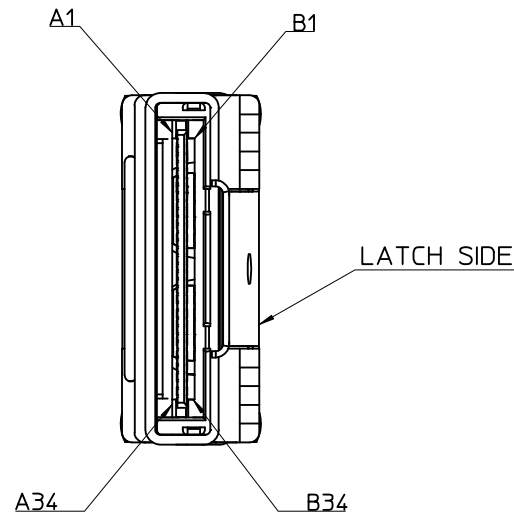

I-PASS™ IS A TRADEMARK OF MOLEX

<b>ENTER DESCRIPTION</b> EC NO: USY2006-0481 DRWN:SNABARRO 2006/06/29 CHKD:BREED 2006/06/29 APPR:DDOYE 2006/07/06	<b>QUALITY SYMBOLS</b> ▽=0 ▽=0	<b>GENERAL TOLERANCES (UNLESS SPECIFIED)</b>		<b>DIMENSION STYLE</b> MM ONLY		SCALE 1:1	DESIGN UNITS METRIC	THIRD ANGLE PROJECTION			
				DRAWN BY BREED	DATE 2004/11/09	TITLE I-PASS X8 CABLE ASSEMBLY GEN 1					
				CHECKED BY DDOYE	DATE 2004/11/09						
				APPROVED BY DDOYE		DATE 2004/11/09	MOLEX MOLEX INCORPORATED				
		MATERIAL NO. SEE TABLE		DOCUMENT NO. SD-74546-800			SHEET NO. 2 OF 3				
		DRAFT WHERE APPLICABLE MUST REMAIN WITHIN DIMENSIONS								THIS DRAWING CONTAINS INFORMATION THAT IS PROPRIETARY TO MOLEX INCORPORATED AND SHOULD NOT BE USED WITHOUT WRITTEN PERMISSION	

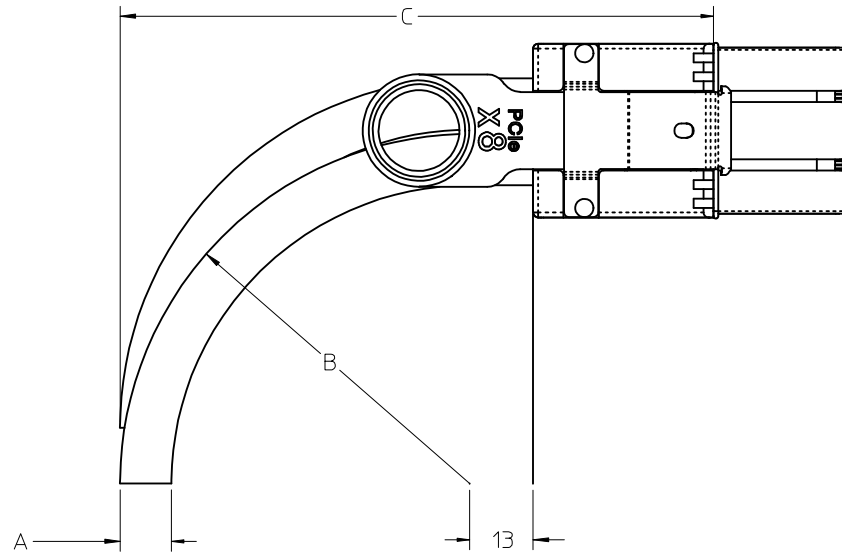

CABLE GAGE	24	26	28
A. CABLE DIAMETER	10.4	9.3	8.4
B. MINIMUM OUTER RADIUS	46.9	41.7	37.7
C. FACEPLATE TO OUTER RADIUS	102.2	97.0	93.0

I-PASS™ IS A TRADEMARK OF MOLEX

<b>ENTER DESCRIPTION</b> EC NO: USY2006-0481 DRWN: SNAVARRO 2006/06/29 CHKD: BREED 2006/06/29 APPR: DDOYE 2006/07/06	<b>QUALITY SYMBOLS</b> ▽=0 ▽=0	<b>GENERAL TOLERANCES (UNLESS SPECIFIED)</b>		<b>DIMENSION STYLE</b> MM ONLY	SCALE 1:1	DESIGN UNITS METRIC	THIRD ANGLE PROJECTION
		4 PLACES ± --- ± ---	DRAWN BY BREED	DATE 2004/11/09	TITLE I-PASS X8 CABLE ASSEMBLY GEN 1		
		3 PLACES ± --- ± ---	CHECKED BY DDOYE	DATE 2004/11/09			
		2 PLACES ± 0.13 ± --- 1 PLACE ± 0.25 ± ---	APPROVED BY DDOYE	DATE 2004/11/09	MOLEX INCORPORATED		
ANGULAR ± 1/2°	MATERIAL NO. SEE TABLE	DOCUMENT NO. SD-74546-800	SHEET NO. 3 OF 3				
DRAFT WHERE APPLICABLE MUST REMAIN WITHIN DIMENSIONS		SIZE B	THIS DRAWING CONTAINS INFORMATION THAT IS PROPRIETARY TO MOLEX INCORPORATED AND SHOULD NOT BE USED WITHOUT WRITTEN PERMISSION				