



Chipsmall Limited consists of a professional team with an average of over 10 year of expertise in the distribution of electronic components. Based in Hongkong, we have already established firm and mutual-benefit business relationships with customers from,Europe,America and south Asia,supplying obsolete and hard-to-find components to meet their specific needs.

With the principle of “Quality Parts,Customers Priority,Honest Operation,and Considerate Service”,our business mainly focus on the distribution of electronic components. Line cards we deal with include Microchip,ALPS,ROHM,Xilinx,Pulse,ON,Everlight and Freescale. Main products comprise IC,Modules,Potentiometer,IC Socket,Relay,Connector.Our parts cover such applications as commercial,industrial, and automotives areas.

We are looking forward to setting up business relationship with you and hope to provide you with the best service and solution. Let us make a better world for our industry!



## Contact us

Tel: +86-755-8981 8866 Fax: +86-755-8427 6832

Email & Skype: info@chipsmall.com Web: www.chipsmall.com

Address: A1208, Overseas Decoration Building, #122 Zhenhua RD., Futian, Shenzhen, China



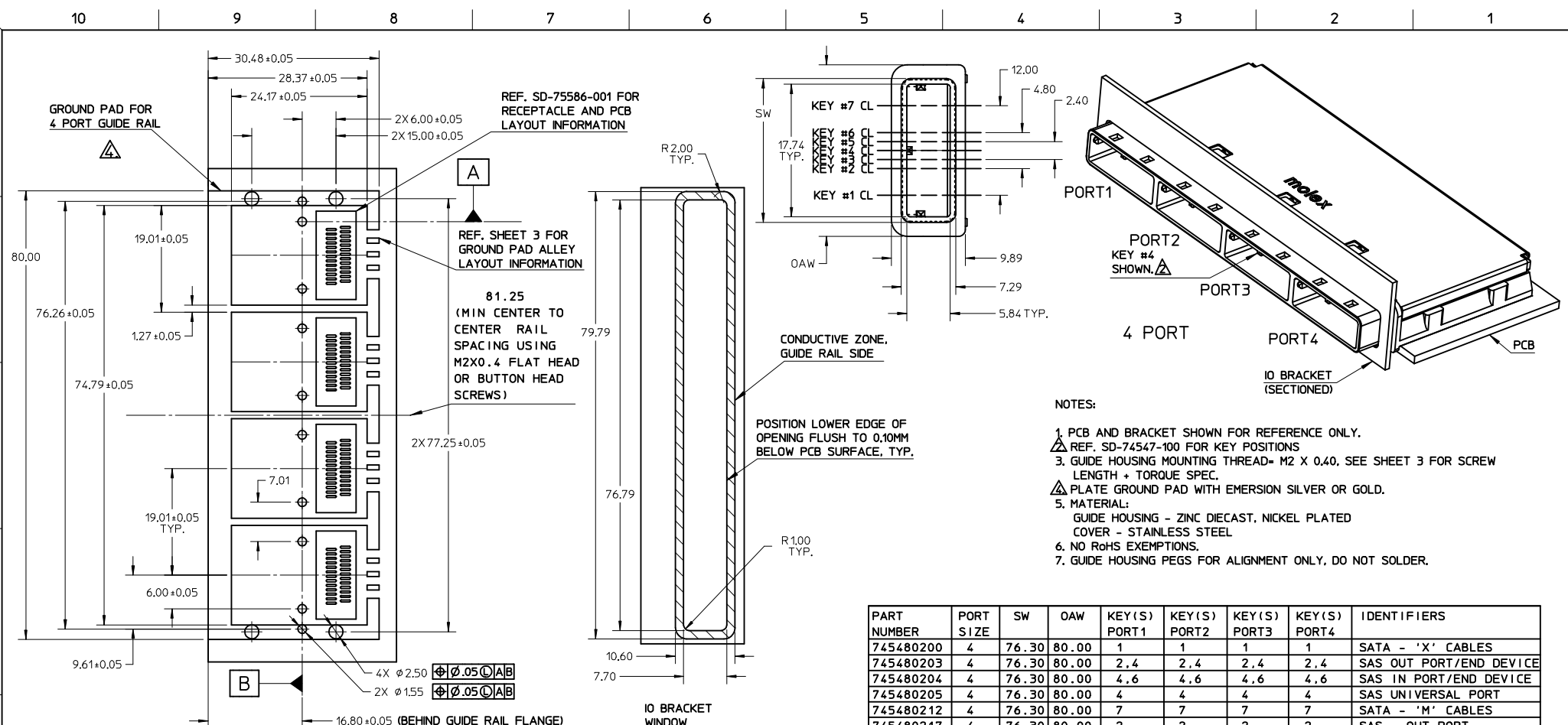

- NOTES:
1. PCB AND BRACKET SHOWN FOR REFERENCE ONLY.
  2. REF. SD-74547-100 FOR KEY POSITIONS
  3. GUIDE HOUSING MOUNTING THREAD= M2 X 0.40. SEE SHEET 3 FOR SCREW LENGTH + TORQUE SPEC.
  4. PLATE GROUND PAD WITH EMERSION SILVER OR GOLD.
  5. MATERIAL:  
GUIDE HOUSING - ZINC DIECAST, NICKEL PLATED  
COVER - STAINLESS STEEL
  6. NO RoHS EXEMPTIONS.
  7. GUIDE HOUSING PEGS FOR ALIGNMENT ONLY, DO NOT SOLDER.

PART NUMBER	PORT SIZE	SW	OAW	KEY(S) PORT1	KEY(S) PORT2	KEY(S) PORT3	KEY(S) PORT4	IDENTIFIERS
745480200	4	76.30	80.00	1	1	1	1	SATA - 'X' CABLES
745480203	4	76.30	80.00	2,4	2,4	2,4	2,4	SAS OUT PORT/END DEVICE
745480204	4	76.30	80.00	4,6	4,6	4,6	4,6	SAS IN PORT/END DEVICE
745480205	4	76.30	80.00	4	4	4	4	SAS UNIVERSAL PORT
745480212	4	76.30	80.00	7	7	7	7	SATA - 'M' CABLES
745480217	4	76.30	80.00	2	2	2	2	SAS - OUT PORT
745480220	4	76.30	80.00	6	6	6	6	SAS - IN PORT
745480304	4	76.30	80.00	2,7	2,7	2,7	2,7	CX4
745480401	4	76.29	79.99	2,6	4	4	4	CUSTOM

IPASS IS A TRADE MARK OF MOLEX.

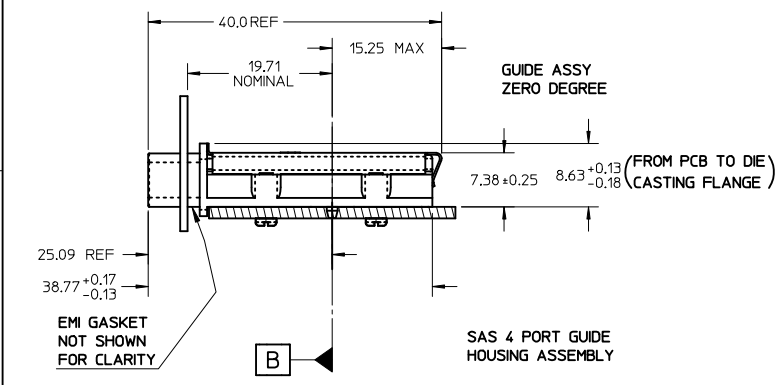

<b>SEE REVISION TABLE</b> EC NO: CPG2015-0132 DRWN:SYANG16 2013/09/27 CHK:EWANG07 2014/08/15 APPR:RCHEN08 2014/08/19	QUALITY SYMBOLS ▽=0 ▽=0 ▽=0	GENERAL TOLERANCES (UNLESS SPECIFIED) mm INCH 4 PLACES ± --- ± --- 3 PLACES ± --- ± --- 2 PLACES ± 0.13 ± --- 1 PLACE ± 0.25 ± --- 0 PLACE ± ±	DIMENSION STYLE MM ONLY DRAWN BY SNAVARRO DATE 2006/05/26 CHECKED BY BREED DATE 2006/05/26 APPROVED BY DDOYE DATE 2006/05/26	SCALE 1:1 DESIGN UNITS METRIC THIRD ANGLE PROJECTION	TITLE <b>I-PASS 26 CKT ZERO DEG. EMI GUIDE RAIL HOUSING ASSEMBLY, MULTI PORT</b>  DOCUMENT NO. SD-74548-200 SHEET NO. 1 OF 4
	ANGULAR ± 1/2° DRAFT WHERE APPLICABLE MUST REMAIN WITHIN DIMENSIONS	MATERIAL NO. SEE TABLE			
	SIZE B	THIS DRAWING CONTAINS INFORMATION THAT IS PROPRIETARY TO MOLEX INCORPORATED AND SHOULD NOT BE USED WITHOUT WRITTEN PERMISSION			

10 9 8 7 6 5 4 3 2 1

F

E

D

C

B

A

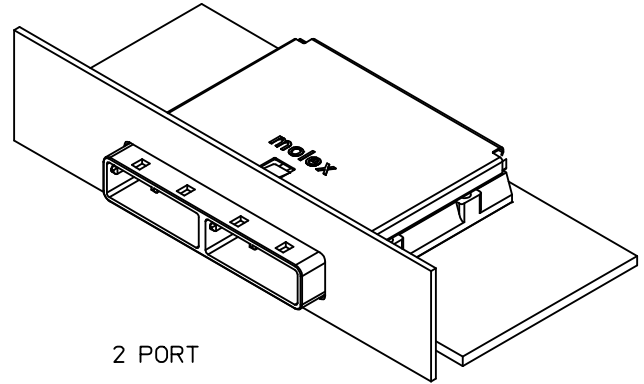
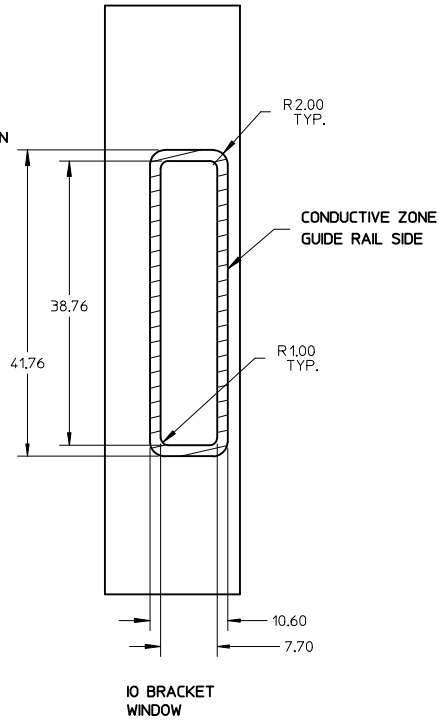
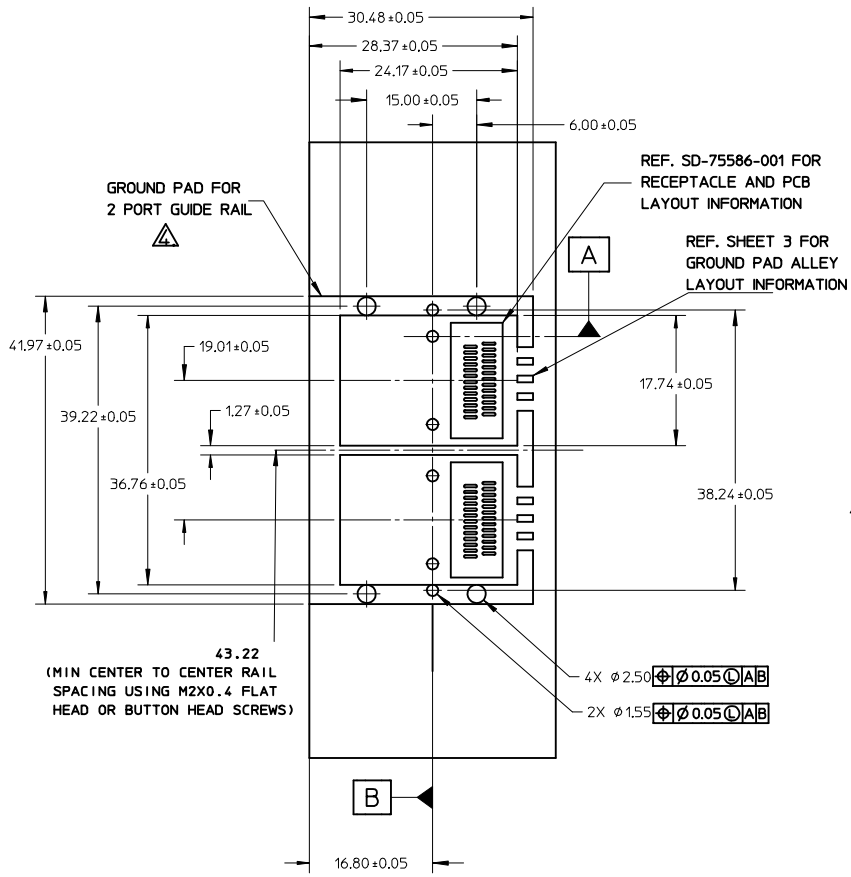

PART NUMBER	PORT SIZE	SW	OAW	KEY(S) PORT1	KEY(S) PORT2	IDENTIFIERS
745480202	2	38.26	41.96	1	1	SATA - 'X' CABLES
745480206	2	38.26	41.96	2,4	2,4	SAS OUT PORT/END DEVICE
745480207	2	38.26	41.96	4,6	4,6	SAS IN PORT/END DEVICE
745480208	2	38.26	41.96	4	4	SAS UNIVERSAL PORT
745480213	2	38.26	41.96	7	7	SATA - 'M' CABLES
745480215	2	38.26	41.96	4,6	2,4	SAS IN PORT - SAS OUT PORT
745480216	2	38.26	41.96	2,4	4,6	SAS OUT PORT - SAS IN PORT
745480218	2	38.26	41.96	2	2	SAS - IN PORT
745480221	2	38.26	41.96	6	6	SAS - OUT PORT
745480224	2	38.26	41.96	3	3	SRIO

I-PASS IS A TRADE MARK OF MOLEX.

<b>SEE REVISION TABLE</b> EC NO: CPG2015-0132 DRWN: SYANG16 2013/09/27 CHKD: WANG07 2014/08/15 APPR: RCHEN08 2014/08/19	QUALITY SYMBOLS	GENERAL TOLERANCES (UNLESS SPECIFIED)	DIMENSION STYLE	SCALE	DESIGN UNITS	THIRD ANGLE PROJECTION	
	▽=0	mm INCH	MM ONLY	1:1	METRIC	⊙	
	▽=0	4 PLACES ± --- ± ---	DRAWN BY DATE	TITLE <b>I-PASS 26 CKT ZERO DEG. EMI GUIDE RAIL HOUSING ASSEMBLY, MULTI PORT</b> 			
	▽=0	3 PLACES ± --- ± ---	CHECKED BY DATE				
	▽=0	2 PLACES ± 0.13 ± ---	BREED 2006/05/26				
	1 PLACE ± 0.25 ± ---	APPROVED BY DATE	MATERIAL NO. DOCUMENT NO. <b>SEE TABLE SD-74548-200</b>				
	0 PLACE ± ±	ANGULAR ± 1/2°	SHEET NO. <b>2 OF 4</b>				
DRAFT WHERE APPLICABLE MUST REMAIN WITHIN DIMENSIONS		THIS DRAWING CONTAINS INFORMATION THAT IS PROPRIETARY TO MOLEX INCORPORATED AND SHOULD NOT BE USED WITHOUT WRITTEN PERMISSION					

9 8 7 6 5 4 3 2 1

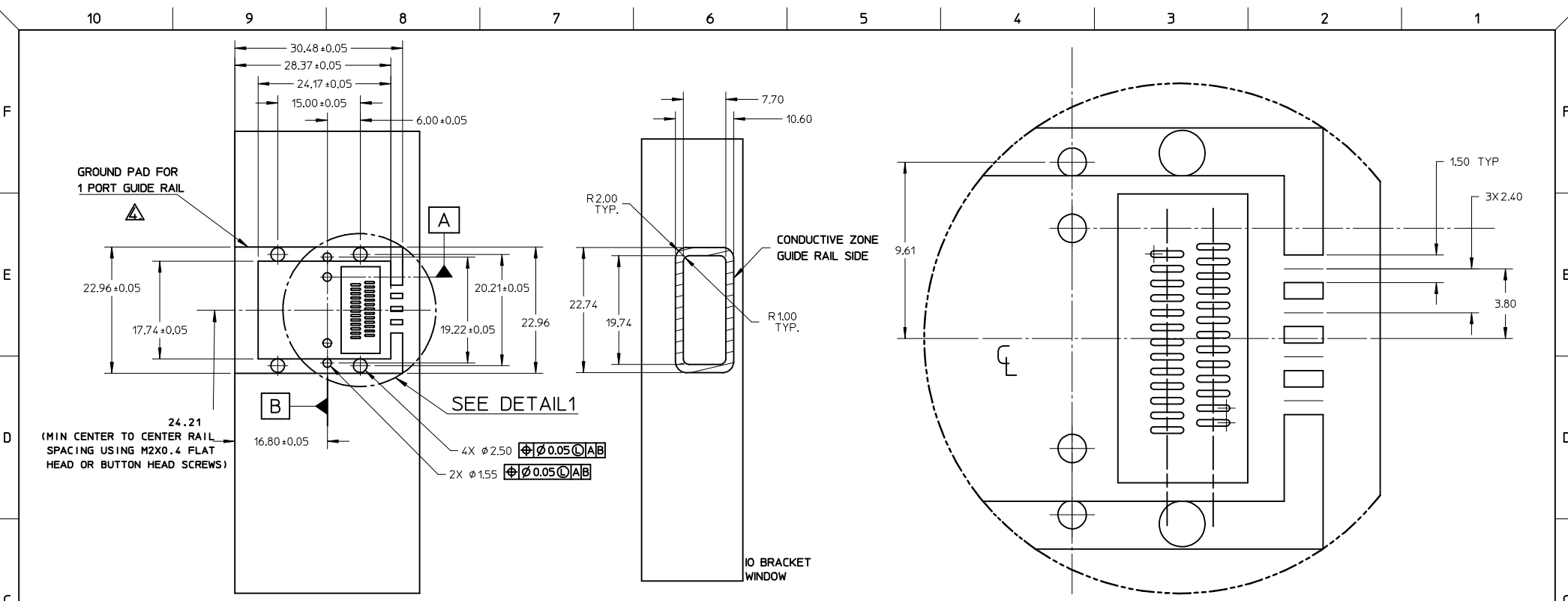

24.21  
(MIN CENTER TO CENTER RAIL  
SPACING USING M2X0.4 FLAT  
HEAD OR BUTTON HEAD SCREWS)

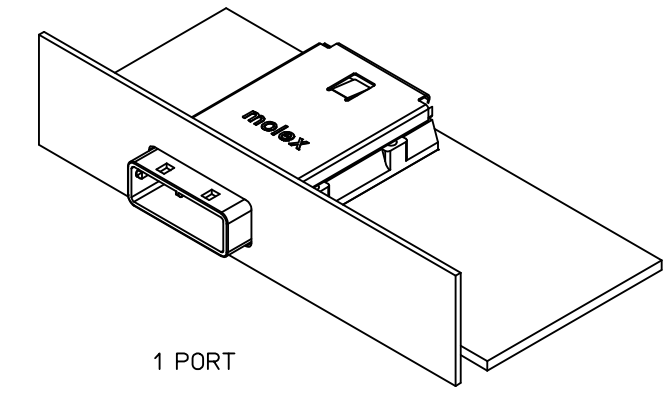

1 PORT

DETAIL1  
Scale 5:1

PART NUMBER	PORT SIZE	SW	OAW	KEY(S)	IDENTIFIERS
745480201	1	19.24	22.95	1	SATA - 'X' CABLES
745480209	1	19.24	22.95	2,4	SAS OUT PORT/END DEVICE
745480210	1	19.24	22.95	4,6	SAS IN PORT/END DEVICE
745480211	1	19.24	22.95	4	SAS UNIVERSAL PORT
745480214	1	19.24	22.95	7	SATA - 'M' CABLES
745480219	1	19.24	22.95	2	SAS OUT PORT
745480222	1	19.24	22.95	6	SAS IN PORT
745480225	1	19.24	22.95	3	SR10
745480229	1	19.24	22.95	2,7	CX4

PCB THICKNESS	SCREW LENGTH	TORQUE (IN LBS)
1.6 (.063')	5MM	2.3
2.38 (.093')	6MM	2.3
3.2 (.125')	6MM	2.3
X	+4MM MAX	2.3

SEE REVISION TABLE EC NO: CPG2015-0132 DRWN:SYANG16 2013/09/27 CHKD:EWANG07 2014/08/15 APPR:RICHEN08 2014/08/19	QUALITY SYMBOLS	GENERAL TOLERANCES (UNLESS SPECIFIED)	DIMENSION STYLE	SCALE	DESIGN UNITS	THIRD ANGLE PROJECTION TITLE <b>I-PASS 26 CKT ZERO DEG. EMI GUIDE RAIL HOUSING ASSEMBLY, MULTI PORT</b> <b>moLEX</b> DOCUMENT NO. <b>SD-74548-200</b> SHEET NO. <b>3 OF 4</b>
	▽=0	mm INCH	MM ONLY	1:1	METRIC	
	▽=0	4 PLACES ± --- ± ---	DRAWN BY DATE			
	▽=0	3 PLACES ± --- ± ---	SNABARRO 2006/05/26			
	2 PLACES ±0.13 ± ---	CHECKED BY DATE				
	1 PLACE ±0.25 ± ---	BREED 2006/05/26				
	0 PLACE ± ±	APPROVED BY DATE				
		DDOYE 2006/05/26				
		ANGULAR ±1/2°	MATERIAL NO.			
		DRAFT WHERE APPLICABLE MUST REMAIN WITHIN DIMENSIONS	SEE TABLE			
			SIZE B			

DATE	REV	DESCRIPTION
2014/08/14	U	1.CHANGED 40.0 TO 40.0 REF $\text{\textcircled{0}B9}$ [SHEET 1] 2.CHANGED DIM 25.09 TO 25.09 REF $\text{\textcircled{0}A10}$ BASED ON SFF-8088 [SHEET 1] 3.ADDDED NOTE FOR DIM 8.63 +0.13/-0.18 $\text{\textcircled{0}A7}$ [SHEET 1] 4.ADDDED DIM 15.25MAX $\text{\textcircled{0}B9}$ BASED ON SFF-8088 [SHEET 1] 5.ADDDED REVISION HISTORY [SHEET 4]. 6.CHANGED ALL LOCATIONS OF DIMENSION MULTIPLIERS. (EX: "YY(3)" TO "3X YY")

SEE REVISION TABLE EC NO: CPG2015-0132 DRWN:SYANG16 2013/09/27 CHKD:EWANG07 2014/08/15 APPR:RCHEN08 2014/08/19	QUALITY SYMBOLS	GENERAL TOLERANCES (UNLESS SPECIFIED)	DIMENSION STYLE	SCALE	DESIGN UNITS	THIRD ANGLE PROJECTION
	$\nabla = 0$	mm INCH	MM ONLY	1:1	METRIC	
	$\nabla = 0$	4 PLACES ± --- ± ---	DRAWN BY DATE	TITLE I-PASS 26 CKT ZERO DEG. EMI GUIDE RAIL HOUSING ASSEMBLY, MULTI PORT		
	$\nabla = 0$	3 PLACES ± --- ± ---	SNAVARRO 2006/05/26			
	$\nabla = 0$	2 PLACES ± 0.13 ± ---	CHECKED BY DATE	DOCUMENT NO. SD-74548-200 SHEET NO. 4 OF 4		
	1 PLACE ± 0.25 ± ---	BREED 2006/05/26				
	0 PLACE ± ±	APPROVED BY DATE	THIS DRAWING CONTAINS INFORMATION THAT IS PROPRIETARY TO MOLEX INCORPORATED AND SHOULD NOT BE USED WITHOUT WRITTEN PERMISSION			
	ANGULAR ± 1/2°	DDOYE 2006/05/26				
	DRAFT WHERE APPLICABLE MUST REMAIN WITHIN DIMENSIONS	MATERIAL NO.				
		SEE TABLE				