



Chipsmall Limited consists of a professional team with an average of over 10 year of expertise in the distribution of electronic components. Based in Hongkong, we have already established firm and mutual-benefit business relationships with customers from,Europe,America and south Asia,supplying obsolete and hard-to-find components to meet their specific needs.

With the principle of “Quality Parts,Customers Priority,Honest Operation,and Considerate Service”,our business mainly focus on the distribution of electronic components. Line cards we deal with include Microchip,ALPS,ROHM,Xilinx,Pulse,ON,Everlight and Freescale. Main products comprise IC,Modules,Potentiometer,IC Socket,Relay,Connector.Our parts cover such applications as commercial,industrial, and automotives areas.

We are looking forward to setting up business relationship with you and hope to provide you with the best service and solution. Let us make a better world for our industry!



Contact us

Tel: +86-755-8981 8866 Fax: +86-755-8427 6832

Email & Skype: info@chipsmall.com Web: www.chipsmall.com

Address: A1208, Overseas Decoration Building, #122 Zhenhua RD., Futian, Shenzhen, China



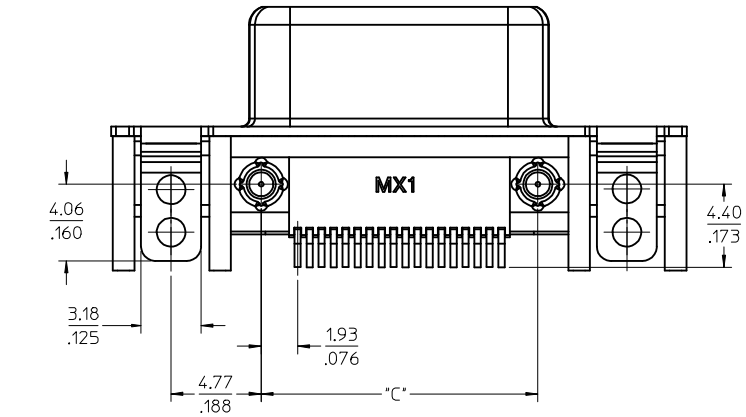
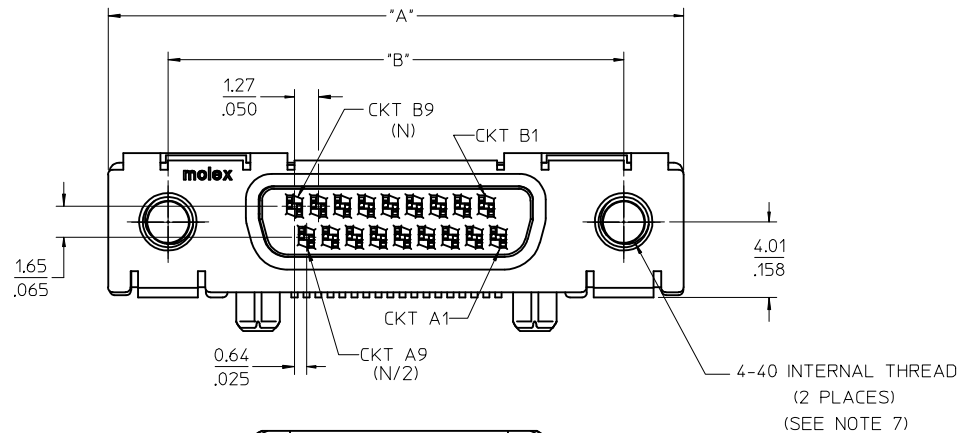
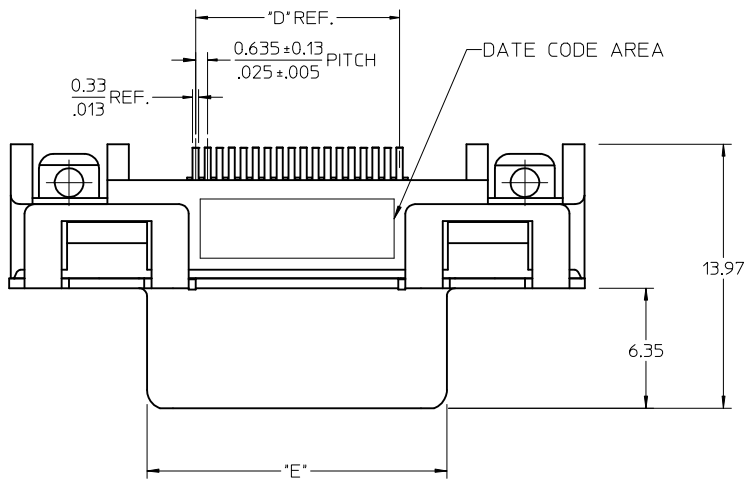

NOTES:

1. MATERIALS:
SHIELD - DEEP DRAWN STEEL
HOUSING - GLASS FILLED POLYMER, BLACK, UL 94V-0
CONTACTS - COPPER ALLOY
JACKPOST - STAINLESS STEEL
THREADED INSERT - BRASS
2. PLATING:
TERMINALS - SELECTIVE GOLD (Au) THICKNESS IN CONTACT AREA, 0.38 MICROMETERS/15 MICROINCHES MINIMUM;
SELECTIVE MATTE TIN (Sn) THICKNESS IN PC TAIL AREA, 2.54 MICROMETERS/100 MICROINCHES MINIMUM;
OVER NICKEL (Ni) UNDERPLATE OVERALL.
SHIELD - 2.54 MICROMETERS/100 MICROINCHES MINIMUM MATTE TIN (Sn) OVER 1.27 MICROMETERS/50 MICROINCHES MINIMUM NICKEL (Ni) OVER COPPER (Cu) UNDERPLATE OVERALL.
3. PC SMT TAILS AND 2 GROUND TABS ARE TO BE COPLANAR WITHIN 0.127/1.005.
4. PARTS TO BE PACKAGED IN TAPE AND REEL. SEE CHART ON SHEET 2 FOR PACKAGING SPECIFICATION.
5. REFER TO SHEET 2 FOR RECOMMENDED PCB LAYOUT AND PANEL CUT-OUT.
6. PRODUCT CONFORMS TO MOLEX PRODUCT SPECIFICATION PS-74960-000.
7. FOR TDP RECEPTACLE WITH M3 INTERNAL THREAD OPTION CONTACT PRODUCT MARKETING.

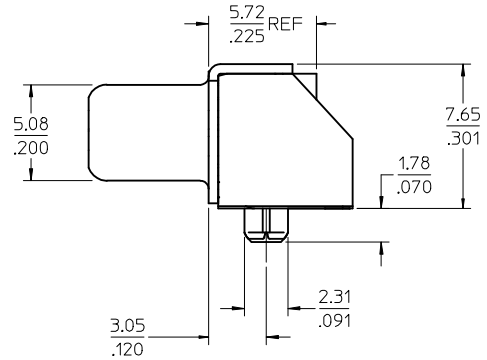

MOD JACKPOST NUMBER EC NO: UCP2015-1626 DRWNT: IBARRA 2014/10/20 CHKD: MORGAN 2014/10/20 APPR: SMILLER 2014/11/12	QUALITY SYMBOLS ∇=0 ∇=0 ∇=0	GENERAL TOLERANCES (UNLESS SPECIFIED)		DIMENSION STYLE MM/IN	SCALE 5:1	DESIGN UNITS INCH	THIRD ANGLE PROJECTION
				DRAWN BY: JJANTELEZ10 DATE: 07/15/2008	TITLE: SALES DRAWING - PCIE/TDP SMT RECEPTACLE ASSEMBLY		
				CHECKED BY: TMCCLELL DATE: 07/15/2008	molex		
				APPROVED BY: MBANAKIS DATE: 2010/10/29		DOCUMENT NO. SD-74960-010	
		ANGULAR ±1/2°		MATERIAL NO. SEE TABLE	SHEET NO. 1 OF 3		
		DRAFT WHERE APPLICABLE MUST REMAIN WITHIN DIMENSIONS		THIS DRAWING CONTAINS INFORMATION THAT IS PROPRIETARY TO MOLEX INCORPORATED AND SHOULD NOT BE USED WITHOUT WRITTEN PERMISSION			

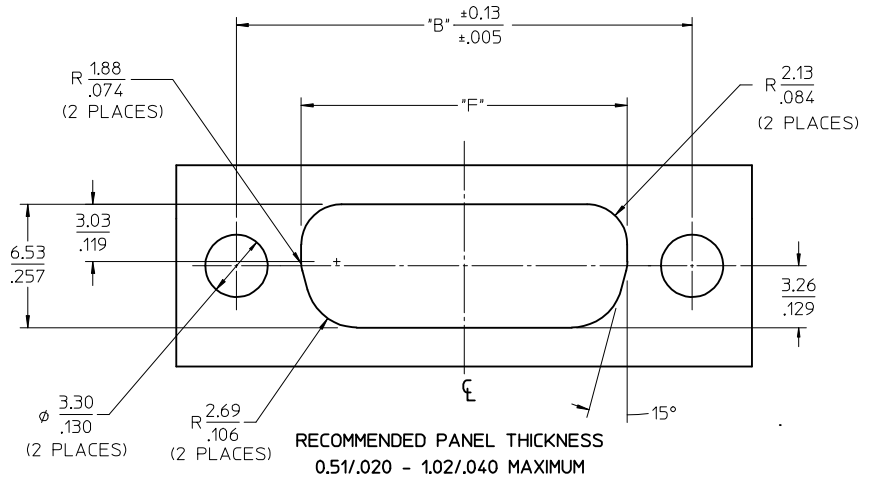
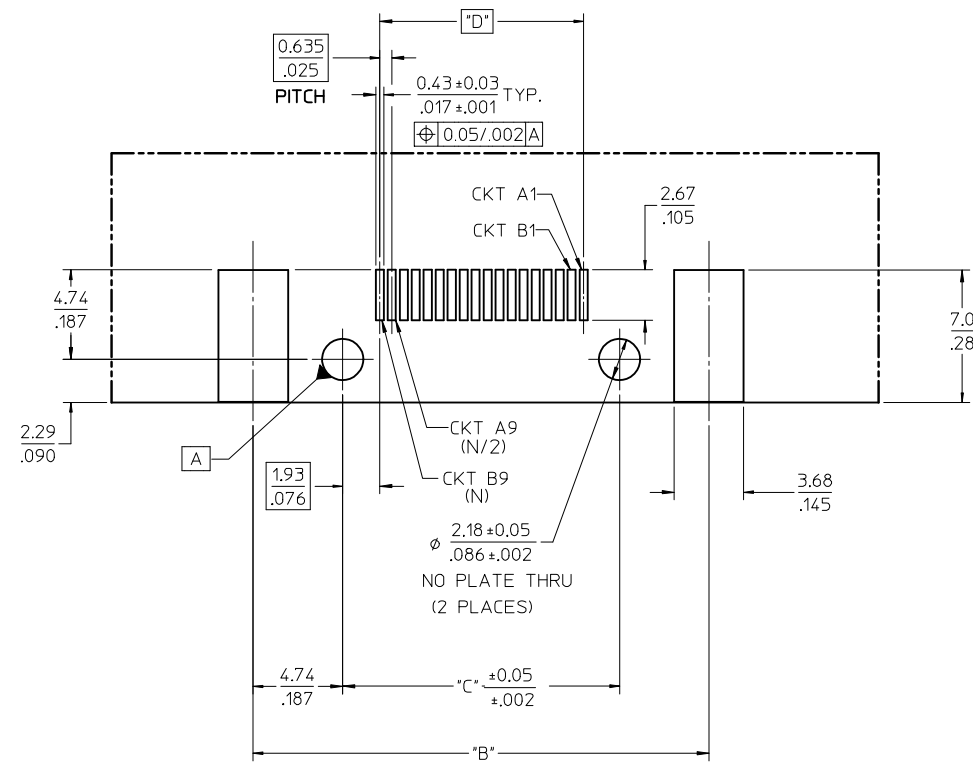

NOT TOOLED	MATERIAL NUMBER	CIRCUIT SIZE	"A" DIMENSION	"B" DIMENSION	"C" DIMENSION	"D" DIMENSION	"E" DIMENSION	"F" DIMENSION	PACKAGING SPECIFICATION	
	74960-3018	18	30.48 / 1.200	24.13 / .950	14.66 / .577	10.80 / .425	15.87 / .625	17.27 / .680	PK-74960-995	
	74960-3028	28	36.83 / 1.450	30.48 / 1.200	21.01 / .827	17.15 / .675	22.17 / .873	23.62 / .930	PK-74960-995	
X	74960-3038	38	43.18 / 1.700	36.83 / 1.450	27.36 / 1.077	23.50 / .925	28.52 / 1.123	29.97 / 1.180	N/A	CONTACT PRODUCT MARKETING
	74960-3048	48	49.53 / 1.950	43.18 / 1.700	33.71 / 1.327	29.85 / 1.175	34.87 / 1.373	36.32 / 1.430	PK-74960-996	
X	74960-3072	72	64.77 / 2.550	58.42 / 2.300	48.95 / 1.927	45.09 / 1.775	50.11 / 1.973	51.56 / 2.030	N/A	CONTACT PRODUCT MARKETING

- NOTES:
- ALL DIMENSIONS ON THIS SHEET ARE ±0.13 TOLERANCE UNLESS OTHERWISE SPECIFIED.
 - DIMENSIONS SHOWN ABOUT A CENTERLINE ARE SYMMETRICAL ABOUT THAT CENTERLINE WITHIN HALF THE SPECIFIED TOLERANCE.
 - PEG HOLES CAN BE 2.18MM / .086IN TO RETAIN PART TO BOARD OR ENLARGED TO 2.4MM / .094IN TO ACT AS CLEARANCE HOLES. A FIXTURE MUST BE USED TO PREVENT PART TILTING DURING REFLOW IF HOLES ARE ENLARGED. REFER TO SECTION 8.1 IN APPLICATION SPECIFICATION AS-74960-100.

SEE SHEET 1 EC NO: UCP2015-1626 DRW: TIBARRA 2014/10/20 CHK: DMORGAN 2014/10/20 APPR: MILLER 2014/11/12	QUALITY SYMBOLS ▽=0 ▽=0 ▽=0	GENERAL TOLERANCES (UNLESS SPECIFIED)		DIMENSION STYLE MM/IN		SCALE 5:1	DESIGN UNITS INCH	THIRD ANGLE PROJECTION		
				DRAWN BY JJANTELEZIO DATE 07/15/2008		CHECKED BY DATE		SALES DRAWING - PCIE/TDP SMT RECEPTACLE ASSEMBLY molex DOCUMENT NO. SD-74960-010 SHEET NO. 2 OF 3		
				APPROVED BY MBANAKIS DATE 2010/10/29						
		ANGULAR ±1/2°		DRAFT WHERE APPLICABLE MUST REMAIN WITHIN DIMENSIONS		SEE TABLE		THIS DRAWING CONTAINS INFORMATION THAT IS PROPRIETARY TO MOLEX INCORPORATED AND SHOULD NOT BE USED WITHOUT WRITTEN PERMISSION		

STANDARD CONFIGURATION

OPTIONAL CONFIGURATION

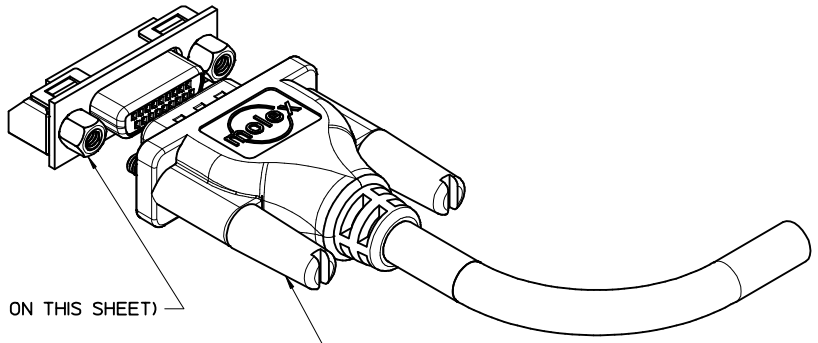

(SEE NOTE 1 ON THIS SHEET)

SEE SALES DRAWING SD-74576-000 FOR STANDARD CABLE PART NUMBER

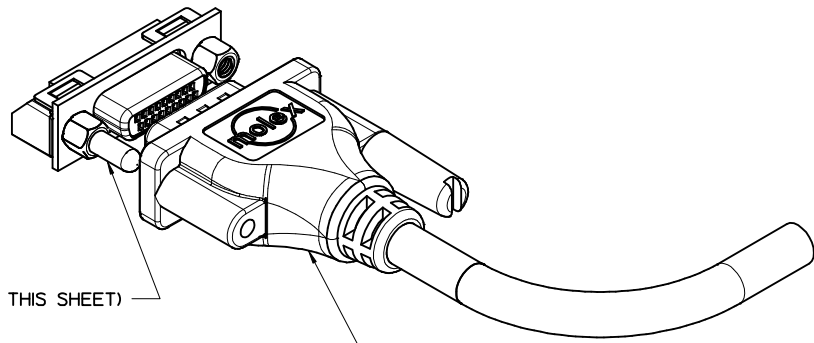

(SEE NOTE 2 ON THIS SHEET)

SEE SALES DRAWING SD-74576-0300 FOR OPTIONAL CABLE PART NUMBER

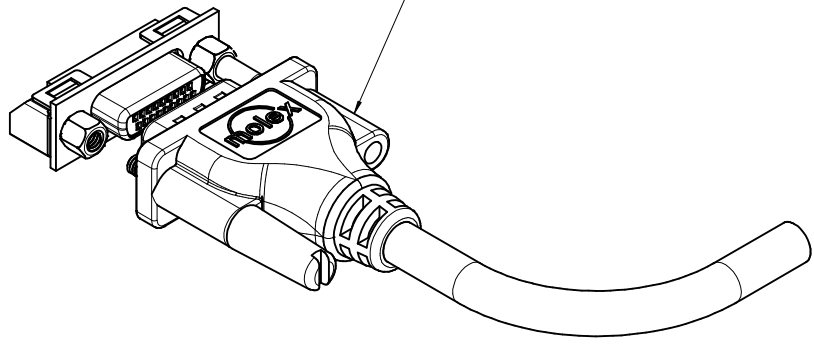

RECOMMENDED JACKPOST INTERNAL THREAD OPTIONS (SEE NOTE 1 ON THIS SHEET)		OPTIONAL JACKPOST POLARIZATION HARDWARE (SEE NOTE 2 ON THIS SHEET)
4-40	M3	
74962-1000	74962-2000	74962-0100
<p>4-40 THREAD INTERNAL THREAD</p>		<p>4-40 THREAD</p>

1. RECOMMENDED JACK POST MOUNTING HARDWARE (QTY 2 PER ASSEMBLY), SEE CHART FOR ITEM NUMBERS AND SALES DRAWING SD-74962-000.
2. OPTIONAL JACK POST POLARIZATION HARDWARE,(QTY 1 PER ASSEMBLY), SEE CHART FOR ITEM NUMBER AND SALES DRAWING SD-74962-100.

SEE SHEET 1 EC NO: UCP2015-1626 DRW:NETIBARRA 2014/10/20 CHK:DJMORGAN 2014/10/20 APPR:SMILLER 2014/11/12	QUALITY SYMBOLS	GENERAL TOLERANCES (UNLESS SPECIFIED)	DIMENSION STYLE	SCALE	DESIGN UNITS	THIRD ANGLE PROJECTION
		mm INCH	MM/IN	4:1	INCH	
		4 PLACES ±.005 ±.005	DRAWN BY	DATE	TITLE	
		3 PLACES ±.005 ±.010	JJANTELEZ10	07/15/2008	SALES DRAWING - PCIE/TDP SMT RECEPTACLE ASSEMBLY	
	2 PLACES ±0.25 ±.015	CHECKED BY	DATE			
	1 PLACE ±0.38 ±.---	TMCCLELL	07/15/2008			
	0 PLACE ±.---	APPROVED BY	DATE			
		MBANAKIS	2010/10/29			
		MATERIAL NO.	SEE TABLE	DOCUMENT NO.	SD-74960-010	
		ANGULAR ±1/2°			SHEET NO. 3 OF 3	
		DRAFT WHERE APPLICABLE MUST REMAIN WITHIN DIMENSIONS			THIS DRAWING CONTAINS INFORMATION THAT IS PROPRIETARY TO MOLEX INCORPORATED AND SHOULD NOT BE USED WITHOUT WRITTEN PERMISSION	