



Chipsmall Limited consists of a professional team with an average of over 10 year of expertise in the distribution of electronic components. Based in Hongkong, we have already established firm and mutual-benefit business relationships with customers from,Europe,America and south Asia,supplying obsolete and hard-to-find components to meet their specific needs.

With the principle of “Quality Parts,Customers Priority,Honest Operation,and Considerate Service”,our business mainly focus on the distribution of electronic components. Line cards we deal with include Microchip,ALPS,ROHM,Xilinx,Pulse,ON,Everlight and Freescale. Main products comprise IC,Modules,Potentiometer,IC Socket,Relay,Connector.Our parts cover such applications as commercial,industrial, and automotives areas.

We are looking forward to setting up business relationship with you and hope to provide you with the best service and solution. Let us make a better world for our industry!



## Contact us

Tel: +86-755-8981 8866 Fax: +86-755-8427 6832

Email & Skype: info@chipsmall.com Web: www.chipsmall.com

Address: A1208, Overseas Decoration Building, #122 Zhenhua RD., Futian, Shenzhen, China



ITEM NUMBER	DIMENSION "A"	HEXAGONAL SCREWLOCKS PACKAGED WITH CONNECTORS	SCREWLOCK ITEM NUMBER (SEE SD-70982-****)	PACKAGED PER PACKAGING SPECIFICATION
75134-1000	.092±.010/2.34±0.25	NO		PK-70873-0291
75134-1001	.092±.010/2.34±0.25	YES	70982-1003; 4-40 INTERNAL THD	PK-70873-0686

NOTES:

1) MATERIALS:

HOUSING: GLASS FILLED LCP (LIQUID CRYSTAL POLYMER), UL94 V-0, COLOR NATURAL.  
 STICK HOUSING: GLASS FILLED LCP (LIQUID CRYSTAL POLYMER), UL94 V-0, COLOR BLACK.  
 TERMINALS: COPPER ALLOY.  
 OUTER SHELL: DEEP DRAWN STEEL.  
 HEXAGONAL SCREWLOCK: STEEL.

2) PLATING :

TERMINAL: SELECTIVE GOLD (Au) FLASH IN CONTACT AREA;  
 THICKNESS= 2 TO 10 MICROINCHES/0.05 TO 0.25 MICROMETERS;  
 SELECTIVE TIN (Sn) ALLOY IN THE PC TAIL AREA;  
 THICKNESS=100 MICROINCHES/2.54 MICROMETERS MINIMUM;  
 NICKEL (Ni) UNDERPLATE OVER ENTIRE PIN.

OUTER SHELL: 150 MICROINCHES/3.81 MICROMETERS MINIMUM OF BRIGHT TIN  
 OVER 50 MICROINCHES/1.27 MICROMETERS MINIMUM OF NICKEL  
 OVER COPPER FLASH (OPTIONAL).

3) CONFORMS TO PRODUCT SPECIFICATION PS-75134-001.

4) THREAD GAGE MAY REQUIRE UP TO 1 INCH-POUND/0.113 NEWTON-METER OF TORQUE DURING GAGING PROCESS.

5) SEE CHART FOR PACKAGING.

6) PART COMPLIES WITH CLASS B OF COSMETIC SPECIFICATION PS-45499-002

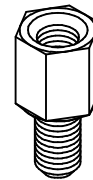
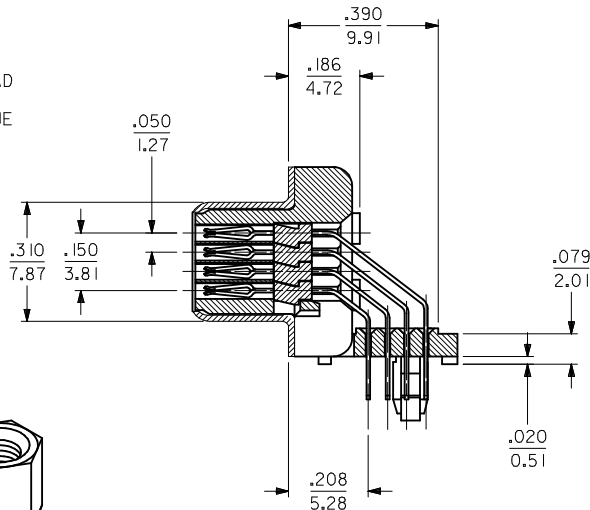
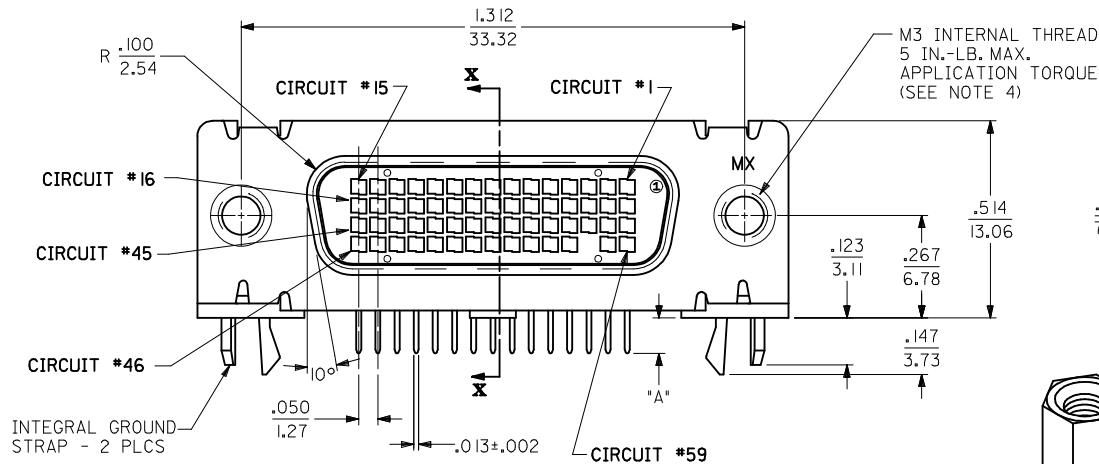
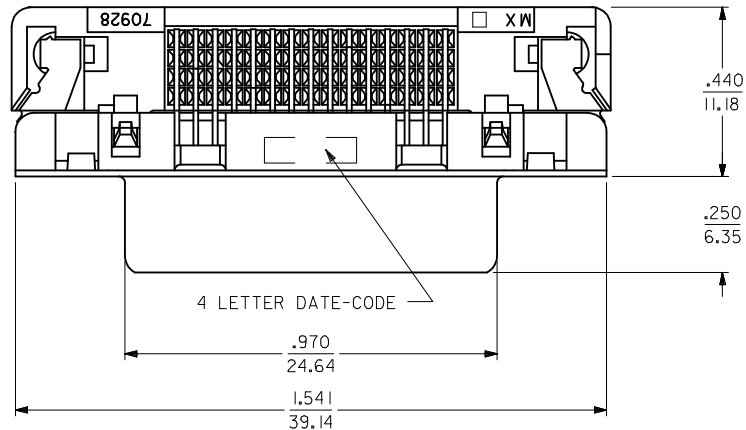

OPTIONAL  
HEXAGONAL SCREWLOCK

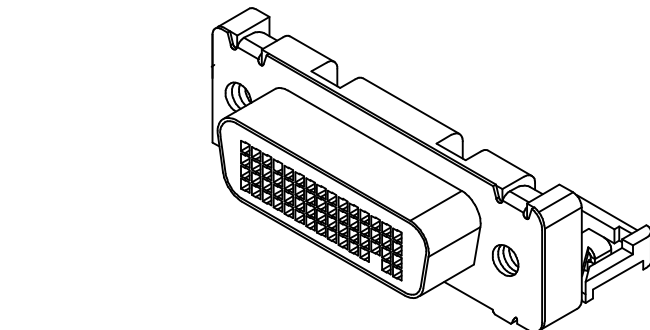

MODIFY T/A ACTUAL EC NO: UCP2009-2635 DRWING:MORGAN 2009/04/29 CHKD:SDANNELLEY 2009/04/30 APPR:SMILLER 2009/04/30	QUALITY SYMBOLS ▽=0 ▽=0	GENERAL TOLERANCES (UNLESS SPECIFIED)		DIMENSION STYLE IN/MM	SCALE INCH	DESIGN UNITS INCH	THIRD ANGLE PROJECTION	
		mm	INCH	DRAWN BY DMORGAN	DATE 2002/10/18	TITLE SALES DMS-59 RECEPTACLE LFH .050/1.27 PITCH RIGHT ANGLE I/O 59 CKT		
		4 PLACES ± --- ± ---	3 PLACES ± --- ± .010	CHECKED BY BBARKER	DATE 2002/10/18	MOLEX INCORPORATED		
		2 PLACES ± 0.25 ± .015	1 PLACE ± 0.38 ± ---	APPROVED BY SMILLER	DATE 2002/10/18	MOLEX INCORPORATED		
ANGULAR ±1/2°		DRAFT WHERE APPLICABLE MUST REMAIN WITHIN DIMENSIONS		MATERIAL NO. SEE TABLE	DOCUMENT NO. SD-75134-001	SHEET NO. 1 OF 2		
THIS DRAWING CONTAINS INFORMATION THAT IS PROPRIETARY TO MOLEX INCORPORATED AND SHOULD NOT BE USED WITHOUT WRITTEN PERMISSION								

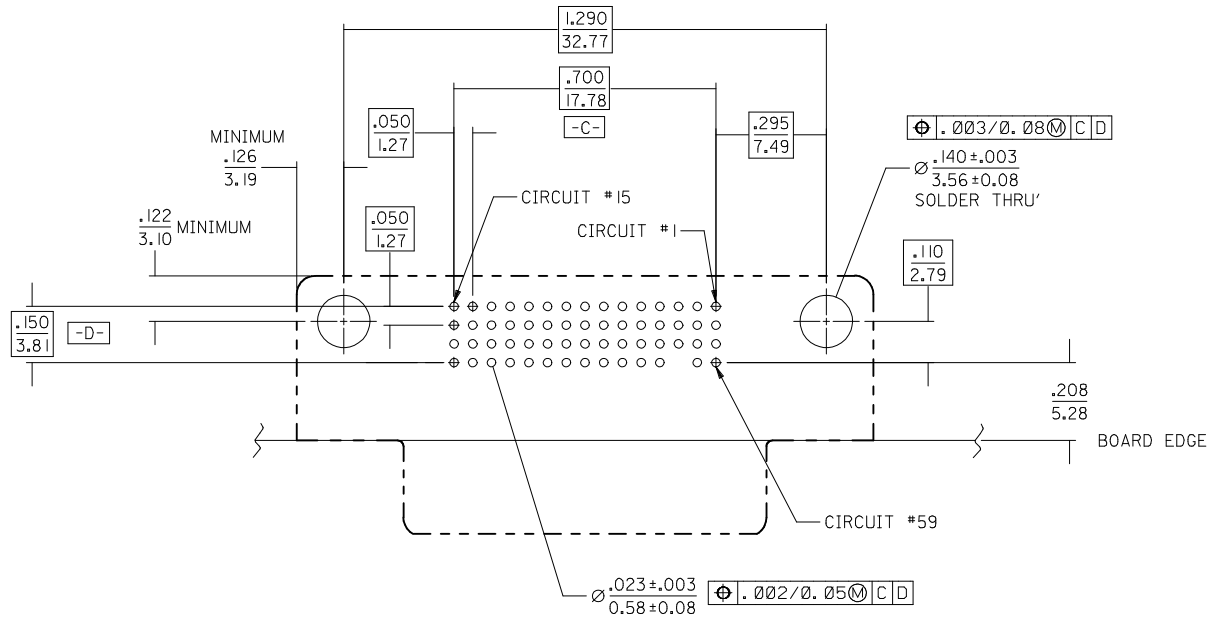

COMPONENT SIDE  
RECOMMENDED P.C.B. LAYOUT

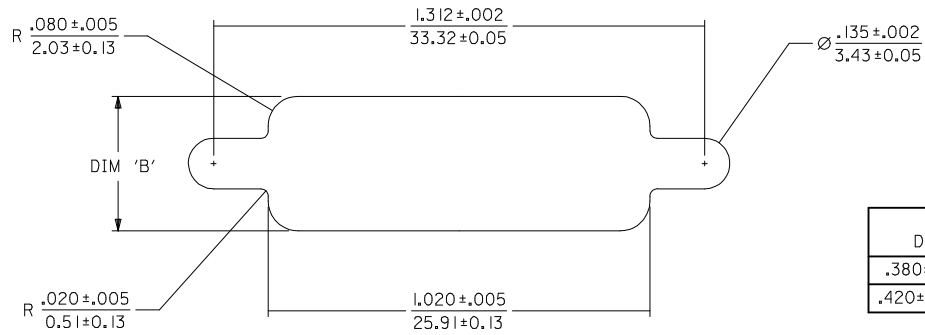

DIMENSION 'B'	MAXIMUM PANEL THICKNESS
.380 ± .005 / 9.65 ± 0.13	.039 / 0.99
.420 ± .005 / 10.67 ± 0.13	.064 / 1.63

RECOMMENDED PANEL CUT-OUT

<b>SEE SHEET 1</b> IEC NO: UCP2009-2635 DRW:DMORGAN 2009/04/28 CHK:D.SANNELLEY 2009/04/30 APPR:SMILLER 2009/04/30	QUALITY SYMBOLS ▽=0 ▽=0	GENERAL TOLERANCES (UNLESS SPECIFIED)		DIMENSION STYLE IN/MM		SCALE 4:1	DESIGN UNITS INCH	THIRD ANGLE PROJECTION	
		4 PLACES	± .---	± .---	DRAWN BY	DATE	TITLE <b>SALES DMS-59 RECEPTACLE          LFH .050/1.27 PITCH          RIGHT ANGLE I/O 59 CKT</b>		
		3 PLACES	± .---	± .010	CHECKED BY	DATE			
		2 PLACES	± .025	± .015	APPROVED BY	DATE	MATERIAL NO. <b>MOLEX INCORPORATED</b>		
1 PLACE	± .038	± .---	SMILLER	2002/10/18	DOCUMENT NO.	SHEET NO.			
DRAFT WHERE APPLICABLE MUST REMAIN WITHIN DIMENSIONS		SEE TABLE		SD-75134-001		2 OF 2		THIS DRAWING CONTAINS INFORMATION THAT IS PROPRIETARY TO MOLEX INCORPORATED AND SHOULD NOT BE USED WITHOUT WRITTEN PERMISSION	

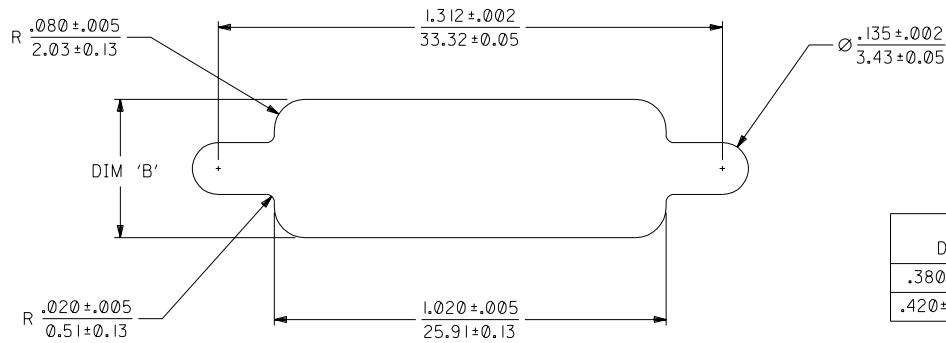
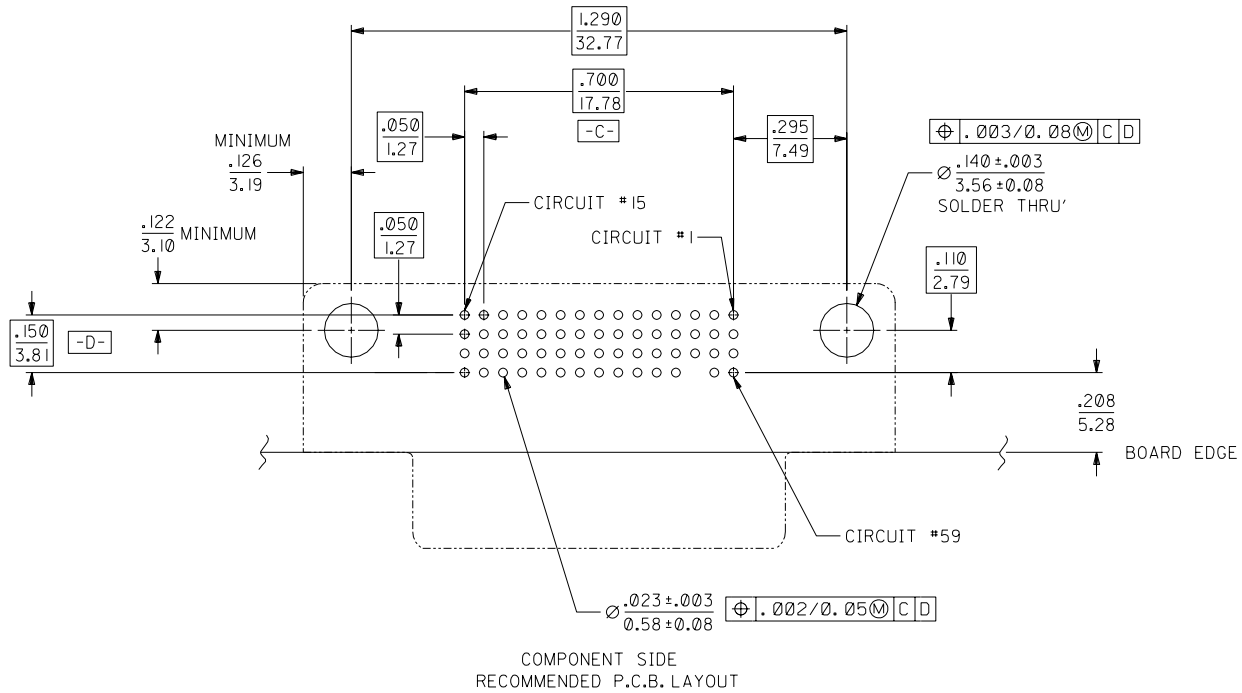

DIMENSION 'B'	MAXIMUM PANEL THICKNESS
.380 ± .005 / 9.65 ± 0.13	.039 / 0.99
.420 ± .005 / 10.67 ± 0.13	.064 / 1.63

RECOMMENDED PANEL CUT-OUT

INITIAL RELEASE EC NO. UCP2003-0543 DRWN:DMORGAN 02/10/18 CHK: BBARKER 02/10/18 APPR: SMILLER 02/10/18	DESCRIPTION MAJOR CRITICAL	QUALITY SYMBOLS	GENERAL TOLERANCES: (UNLESS SPECIFIED)	SCALE 4:1	DESIGN UNITS <input type="checkbox"/> mm <input checked="" type="checkbox"/> INCH	DIMENSIONS: <input type="checkbox"/> mm <input checked="" type="checkbox"/> INCH <input type="checkbox"/> mm ONLY	SHT	REV
		MAJOR CRITICAL	4 PLACES ±0.     ±.	DRAWN BY & DATE DMORGAN 02/10/18	THIRD ANGLE PROJECTION	REVISE ON CAD ONLY		
REV A	DESCRIPTION	3 PLACES ±0.     ±.010	3 PLACES ±0.25     ±.015	CHECKED BY & DATE BBARKER 02/10/18	TITLE: SALES DMS-59 RECEPTALCE LFH .050/1.27 PITCH RIGHT ANGLE I/O 59 CKT			
		1 PLACE ±0.38     ±.	ANGULAR: ± 1/2 °	APPROVED BY & DATE SMILLER 02/10/18	MOLEX INCORPORATED			
		DRAFT WHERE APPLICABLE MUST REMAIN WITHIN DIMENSIONS		CAD FILENAME	MATERIAL NO. SEE CHART	DRAWING NO. SD-75134-001	SHEET NO. 2	SIZE C
THIS DRAWING CONTAINS INFORMATION THAT IS PROPRIETARY TO MOLEX INCORPORATED AND SHOULD NOT BE USED WITHOUT WRITTEN PERMISSION.								