



Chipsmall Limited consists of a professional team with an average of over 10 year of expertise in the distribution of electronic components. Based in Hongkong, we have already established firm and mutual-benefit business relationships with customers from,Europe,America and south Asia,supplying obsolete and hard-to-find components to meet their specific needs.

With the principle of “Quality Parts,Customers Priority,Honest Operation,and Considerate Service”,our business mainly focus on the distribution of electronic components. Line cards we deal with include Microchip,ALPS,ROHM,Xilinx,Pulse,ON,Everlight and Freescale. Main products comprise IC,Modules,Potentiometer,IC Socket,Relay,Connector.Our parts cover such applications as commercial,industrial, and automotives areas.

We are looking forward to setting up business relationship with you and hope to provide you with the best service and solution. Let us make a better world for our industry!



## Contact us

Tel: +86-755-8981 8866 Fax: +86-755-8427 6832

Email & Skype: info@chipsmall.com Web: www.chipsmall.com

Address: A1208, Overseas Decoration Building, #122 Zhenhua RD., Futian, Shenzhen, China



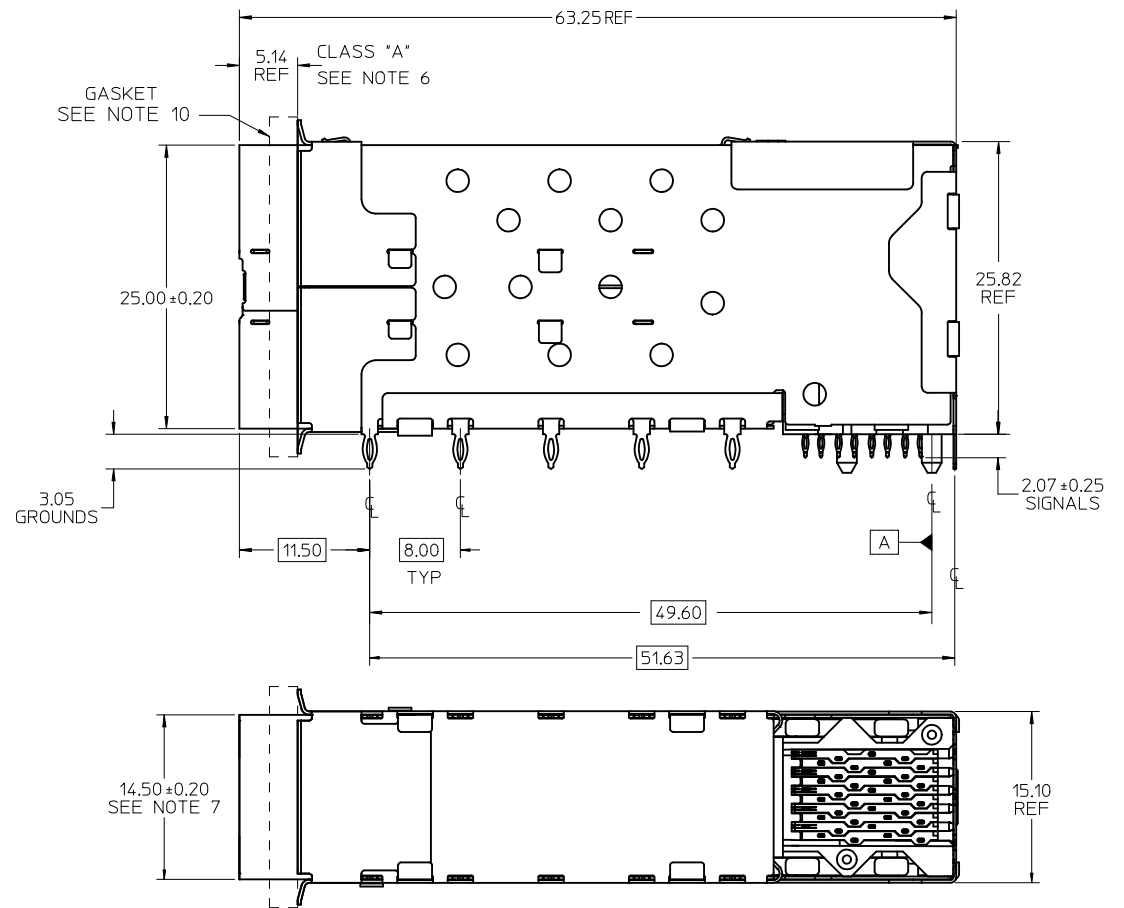
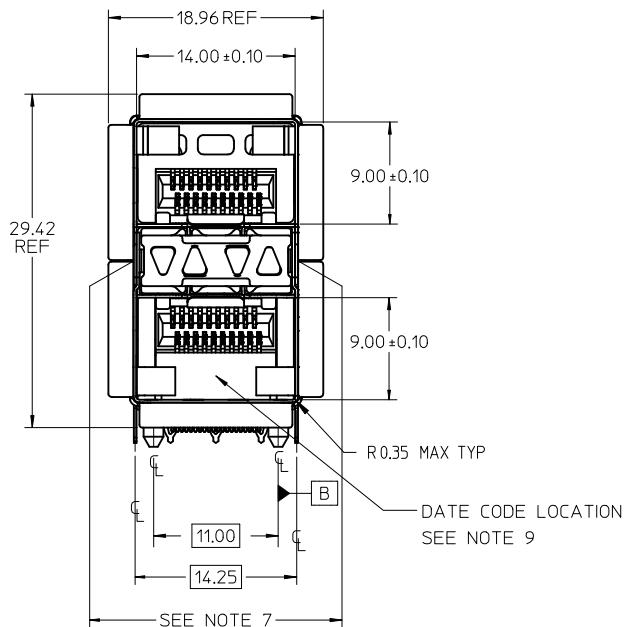

**NOTES**

- MATERIAL:**  
EMI GASKET: CONDUCTIVE ELASTOMER  
CAGE: NICKEL SILVER, THICKNESS: 0.25mm  
CAGE FLANGE: STAINLESS STEEL  
CONNECTOR HOUSING: GLASS FILLED LIQUID CRYSTAL POLYMER (LCP), UL 94V-0, COLOR: BLACK  
OVERMOLD TERMINAL HOUSING: GLASS FILLED LIQUID CRYSTAL POLYMER (LCP), UL 94V-0, COLOR: BLACK  
TERMINALS: TIN BRASS  
LIGHTPIPES: POLYCARBONATE, 94 V-0, CLEAR  
LIGHTPIPE HOUSING: ZINC
- FINISHES:**  
TERMINALS: CONTACT AREA: 0.76 MICROMETERS MINIMUM HARD GOLD OVER 1.27 MICROMETERS MINIMUM NICKEL.  
COMPLIANT TAIL - MATTE TIN/LEAD OPTION: 0.76 TO 1.52 MICROMETERS 90/10 MATTE TIN-LEAD OVER 0.76 MICROMETERS MINIMUM NICKEL.  
COMPLIANT TAIL - MATTE TIN OPTION: 0.76 TO 1.52 MICROMETERS MATTE TIN OVER 0.76 MICROMETERS MINIMUM NICKEL.  
LIGHTPIPE HOUSING: 80 MICROMETERS MINIMUM NICKEL OVER COPPER
- REFER TO PS-75310-001 PRODUCT SPEC FOR ALL ELECTRICAL, MECHANICAL, AND ENVIRONMENTAL SPECIFICATIONS.
- LIGHTPIPE PAD LAYOUT IS FOR 0805 LOW-PROFILE LED PACKAGE, FOR OTHER RECOMMENDED LAYOUTS REFER TO MOLEX'S REPORT TS-75310-001.
- REFER TO PK-76090-0001 FOR ALL PACKAGING SPECIFICATIONS.
- THE SURFACES CONFORM TO THE MOLEX COSMETIC SPEC PS-45499-002. ALL EXTERIOR SURFACES TO BE CLASS "B" SURFACE EXCEPT THE UNDERSIDE (CLASS "C") OF THE CAGE (SIDE TOWARD THE PCB) AND AS OTHERWISE NOTED.
- THE OVERALL CAGE WIDTH AT THE VERTICAL CENTER OF THE FRONT EDGE WILL FALL WITHIN THIS DIMENSION: 14.75+/-0.30 MM. THIS PORTION OF THE CAGE WILL FLEX INWARD AS THE CAGE IS BEING INSERTED INTO THE BEZEL OPENING.
- REFER TO AS-76090-001 FOR HIGH SPEED ROUTING RECOMMENDATIONS.
- DATE CODE LOCATION IS SHOWN ABOVE.  
DATE CODE FORMAT: DDDY MX A1  
DDD = DAY OF THE YEAR  
Y = YEAR  
MX = MOLEX  
A = ALPHA CHARACTER - INDICATES MANUFACTURING LINE  
1 = NUMERIC CHARACTER - INDICATES PRODUCTION SHIFT
- ELASTOMERIC GASKETS ARE SUPPLIED SEPARATELY, IN THE BOX WITH THE CONNECTOR ASSEMBLIES.

PART NUMBER	DESCRIPTION - SEE VIEWS ON SHEET 2	COMPLIANT TAIL PLATING
	4 LIGHT PORTS	MATTE TIN / LEAD
	INNER 2 PORTS	MATTE TIN / LEAD
	OUTER 2 PORTS	MATTE TIN / LEAD
	4 LIGHT PORTS	MATTE TIN
	INNER 2 PORTS	MATTE TIN
	OUTER 2 PORTS	MATTE TIN
760907002	INNER 2 PORTS - ENHANCED EMI	MATTE TIN

**ELASTOMERIC GASKETS SUPPLIED LOOSE IN BAGS**

<b>INITIAL RELEASE</b> EC NO: UCP2012-1596 DRWIN:BBARKER 2011/11/16 CHKD:DMORGAN APPR:SMILLER 2011/11/28 DESCRIPTION REV:	QUALITY SYMBOLS	GENERAL TOLERANCES (UNLESS SPECIFIED)	DIMENSION STYLE <b>MM ONLY</b>	SCALE <b>3:1</b>	DESIGN UNITS <b>METRIC</b>	THIRD ANGLE PROJECTION
	▽=0	4 PLACES ± mm INCH ± ---	DRAWN BY DATE BBARKER 2011/11/16	TITLE <b>STACKED SFP+ 2X1 ASS'Y WITH ELASTOMERIC GASKET AND LIGHTPIPES</b>	<b>MOLEX INCORPORATED</b>	SHEET NO. <b>1 OF 4</b>
	▽=0	3 PLACES ± --- ± ---	CHECKED BY DATE	APPROVED BY DATE SMILLER 2011/11/28		
	▽=0	2 PLACES ± 0.13 ± ---	1 PLACE ± 0.25 ± ---	APPROVED BY DATE SMILLER 2011/11/28	DOCUMENT NO. <b>RSD-76090-0001</b>	
		ANGULAR ± 5 °	MATERIAL NO. <b>SEE TABLE</b>	THIS DRAWING CONTAINS INFORMATION THAT IS PROPRIETARY TO MOLEX INCORPORATED AND SHOULD NOT BE USED WITHOUT WRITTEN PERMISSION		
		DRAFT WHERE APPLICABLE MUST REMAIN WITHIN DIMENSIONS	SIZE <b>C</b>			

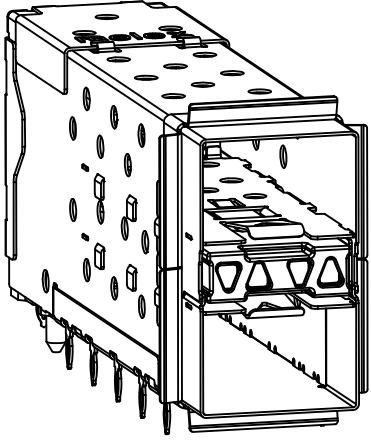

WITH INNER AND OUTER LIGHTPIPES

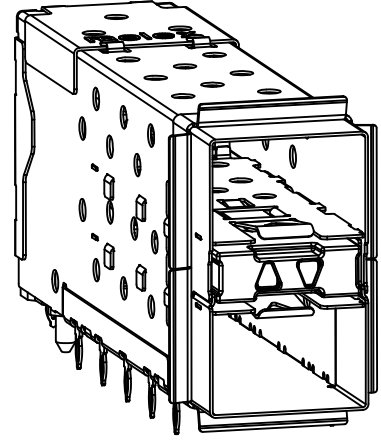

WITH INNER LIGHTPIPES

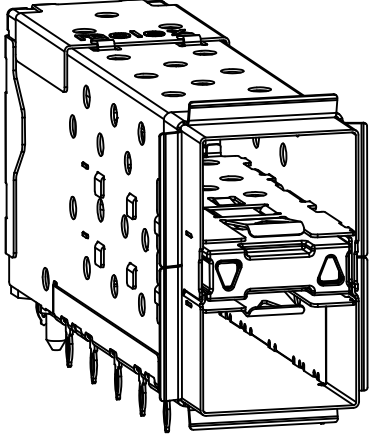

WITH OUTER LIGHTPIPES

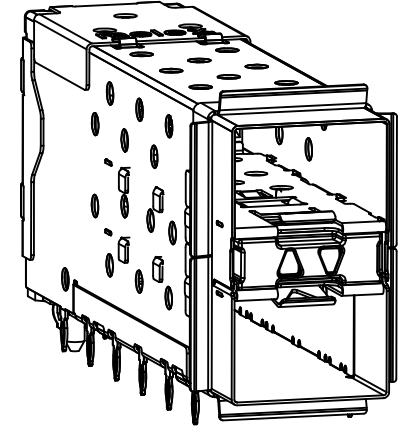

760907002  
WITH INNER LIGHTPIPES  
& ENHANCED EMI MID-SECTION

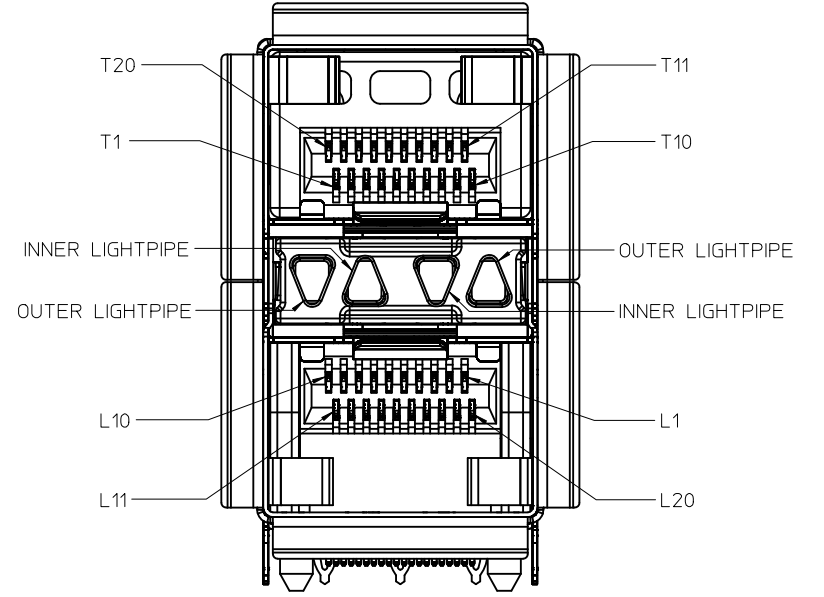

CIRCUIT NUMBERING  
AND LIGHTPIPE  
IDENTIFICATION

SEE SHEET 1 EC NO: UCP2012-1596 DRWN:BBARKER 2011/11/16 CHKD:JMORGAN APPR:SMILLER 2011/11/28	QUALITY SYMBOLS	GENERAL TOLERANCES (UNLESS SPECIFIED)	DIMENSION STYLE	SCALE	DESIGN UNITS	THIRD ANGLE PROJECTION
	▽=0	mm INCH	MM ONLY	3:1	METRIC	
	▽=0	4 PLACES ± --- ± ---	DRAWN BY DATE	TITLE	STACKED SFP+ 2X1 ASS'Y WITH ELASTOMERIC GASKET AND LIGHTPIPES	
	▽=0	3 PLACES ± --- ± ---	BBARKER 2011/11/16	CHECKED BY DATE	MOLEX INCORPORATED	
		2 PLACES ± 0.13 ± ---	APPROVED BY DATE	RSD-76090-0001		SHEET NO. 2 OF 4
		1 PLACE ± 0.25 ± ---	SMILLER 2011/11/28	THIS DRAWING CONTAINS INFORMATION THAT IS PROPRIETARY TO MOLEX INCORPORATED AND SHOULD NOT BE USED WITHOUT WRITTEN PERMISSION		
		ANGULAR ± 5 °	MATERIAL NO.			
		DRAFT WHERE APPLICABLE MUST REMAIN WITHIN DIMENSIONS	SEE TABLE, SHT 1			
			SIZE C			

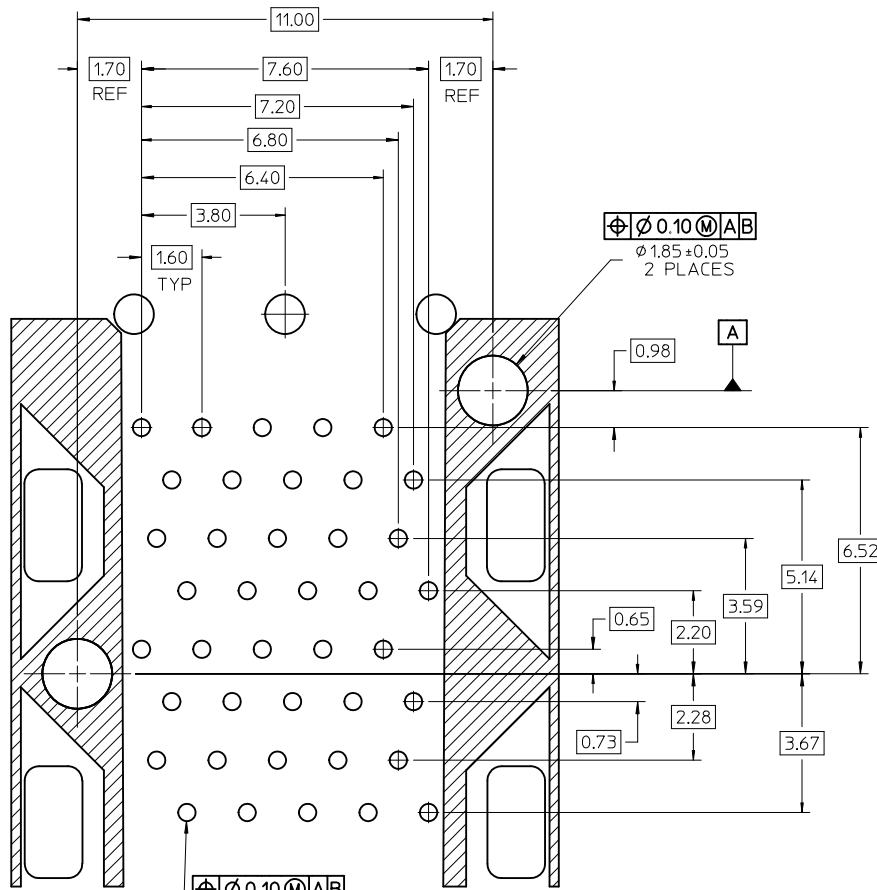

DETAIL A  
SCALE 10:1

⊕ ⌀ 0.10 (M) AB  
 ⌀ 0.46 ± 0.05 TYP  
 (⌀ 0.57 DRILL)  
 (⌀ 0.88 PAD)

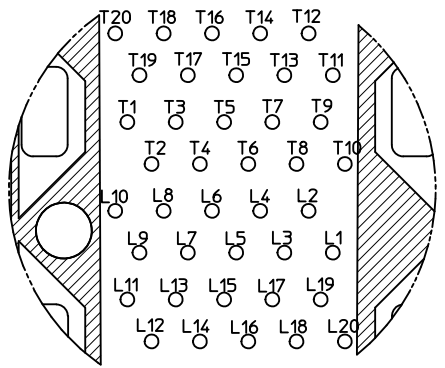

CIRCUIT NUMBERING  
 COMPONENT SIDE OF BOARD  
 SCALE 10:1

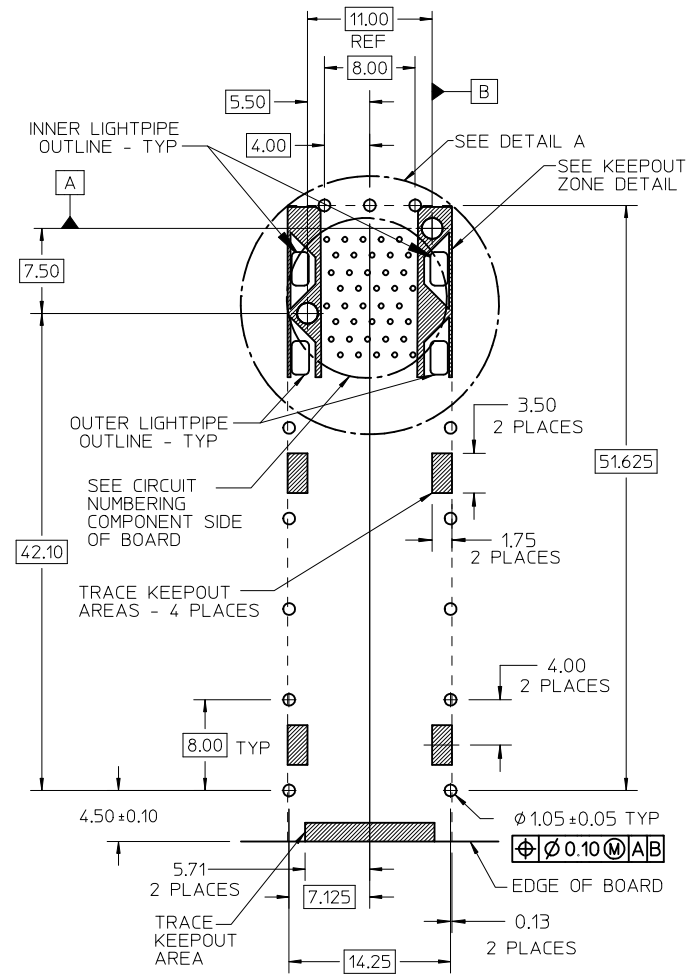

RECOMMENDED PCB LAYOUT - COMPONENT SIDE  
 RECOMMENDED PCB THICKNESS - 2.36 MM (.093 INCH)

THE ENTIRE AREA OF THE CONNECTOR FOOTPRINT  
 TO BE CONSIDERED THE KEEP OUT AREA FOR COMPONENTS  
 (OTHER THAN LIGHTPIPE LED'S)  
 THIS AREA IS INDICATED BY THE DASHED LINE

SEE SHEET 1 EC NO: UCP2012-1596 DRWN:BBARKER 2011/11/16 CHYK:DMORGAN APPR:SMILLER 2011/11/28	QUALITY SYMBOLS	GENERAL TOLERANCES (UNLESS SPECIFIED)		DIMENSION STYLE MM ONLY		SCALE 3:1	DESIGN UNITS METRIC	THIRD ANGLE PROJECTION	
	▽=0	mm	INCH	DRAWN BY BBARKER	DATE 2011/11/16	TITLE <b>STACKED SFP+ 2X1 ASS'Y WITH ELASTOMERIC GASKET AND LIGHTPIPES</b>	<b>MOLEX INCORPORATED</b>	MATERIAL NO. RSD-76090-0001	SHEET NO. 3 OF 4
	▽=0	4 PLACES ± ---	± ---	CHECKED BY	DATE				
	▽=0	3 PLACES ± ---	± ---	APPROVED BY SMILLER	DATE 2011/11/28	THIS DRAWING CONTAINS INFORMATION THAT IS PROPRIETARY TO MOLEX INCORPORATED AND SHOULD NOT BE USED WITHOUT WRITTEN PERMISSION			
▽=0	2 PLACES ± 0.13	± ---	DRAFT WHERE APPLICABLE MUST REMAIN WITHIN DIMENSIONS						
REV	ANGULAR ± 5 °	1 PLACE ± 0.25	± ---	SEE TABLE, SHT 1					

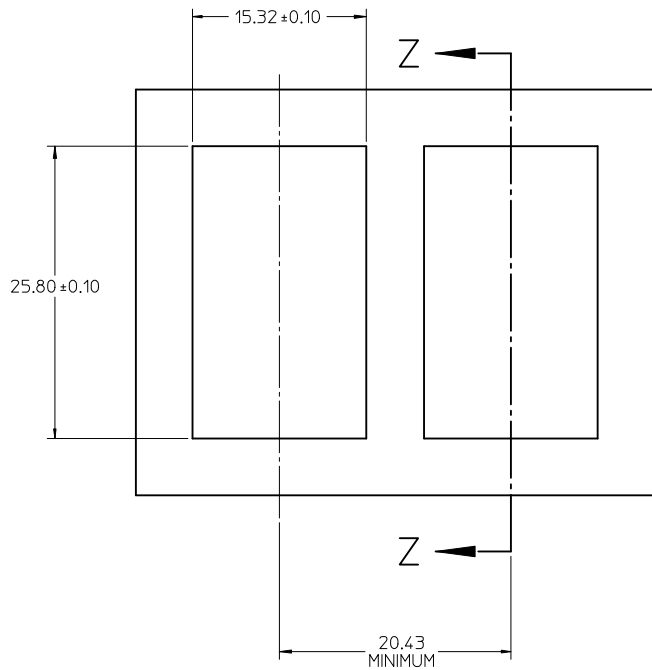

BEZEL CUT-OUT CENTER SPACING DETAIL  
BEZEL THICKNESS 0.8-2.6

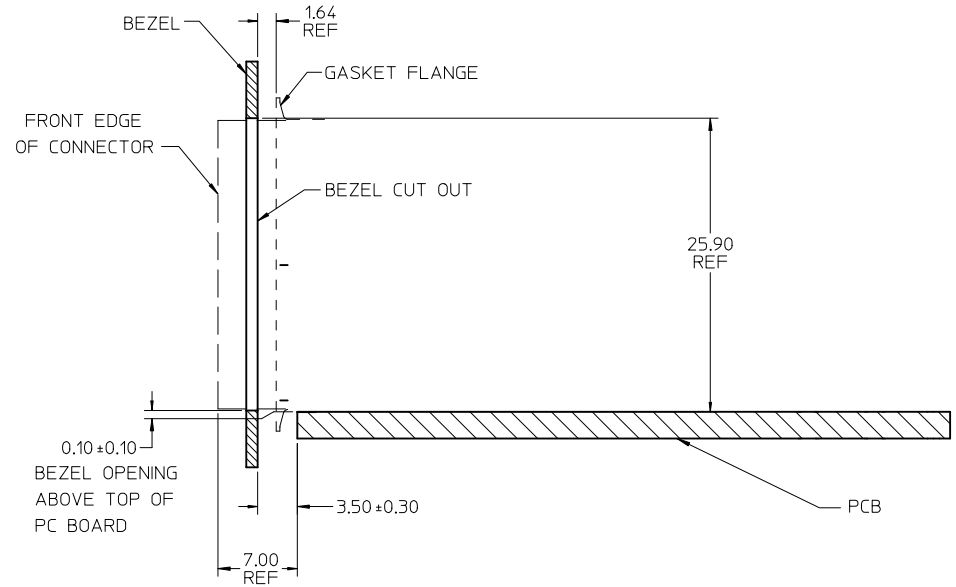

SECTION Z-Z

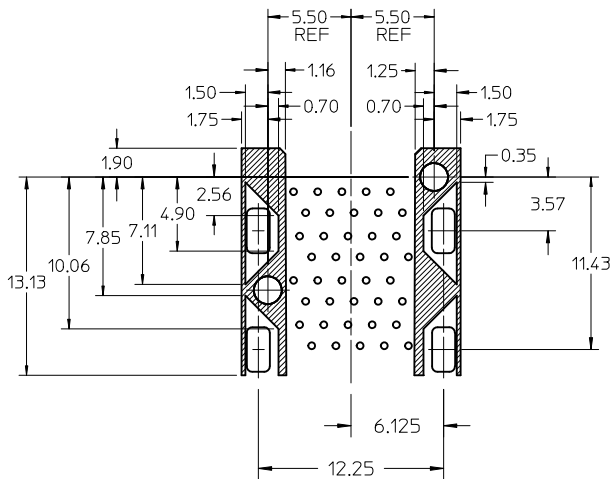

KEEP-OUT ZONE DETAIL - LIGHTPIPE LOCATION AND OTHER ZONES  
SCALE 4:1

THE HATCHED AREA IN THIS VIEW INDICATES ZONES THAT ARE OCCUPIED BY THE PLASTIC HOUSING THAT SEATS AGAINST THE PCB AND BY THE VERTICAL METAL CAGE WALL THAT STOPS JUST SHORT OF THE PCB

SEE SHEET 1 EC NO: UCP2012-1596 DRAWN BY: BBARKER 2011/11/16 CHKD BY: MORGAN APPR: SMILLER 2011/11/28	QUALITY SYMBOLS ▽=0 ▽=0 ▽=0	GENERAL TOLERANCES (UNLESS SPECIFIED)		DIMENSION STYLE <b>MM ONLY</b>	SCALE <b>3:1</b>	DESIGN UNITS <b>METRIC</b>	THIRD ANGLE PROJECTION	
		4 PLACES ± ---	± ---	DRAWN BY BBARKER	DATE 2011/11/16	TITLE <b>STACKED SFP+ 2X1 ASS'Y WITH ELASTOMERIC GASKET AND LIGHTPIPES</b>		
A	REV	3 PLACES ± ---	± ---	CHECKED BY	DATE	APPROVED BY SMILLER		
		2 PLACES ± 0.13	± ---	DATE 2011/11/28		DOCUMENT NO. <b>MOLEX INCORPORATED</b>		
		1 PLACE ± 0.25	± ---	MATERIAL NO.		SHEET NO.		
		ANGULAR ± 5 °		SEE TABLE, SHT 1		RSD-76090-0001		
		DRAFT WHERE APPLICABLE MUST REMAIN WITHIN DIMENSIONS		SIZE C		THIS DRAWING CONTAINS INFORMATION THAT IS PROPRIETARY TO MOLEX INCORPORATED AND SHOULD NOT BE USED WITHOUT WRITTEN PERMISSION		

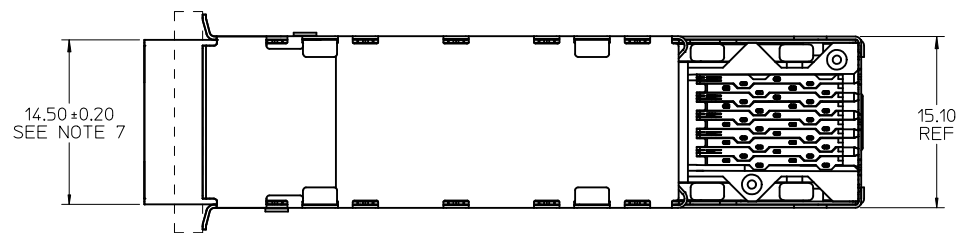
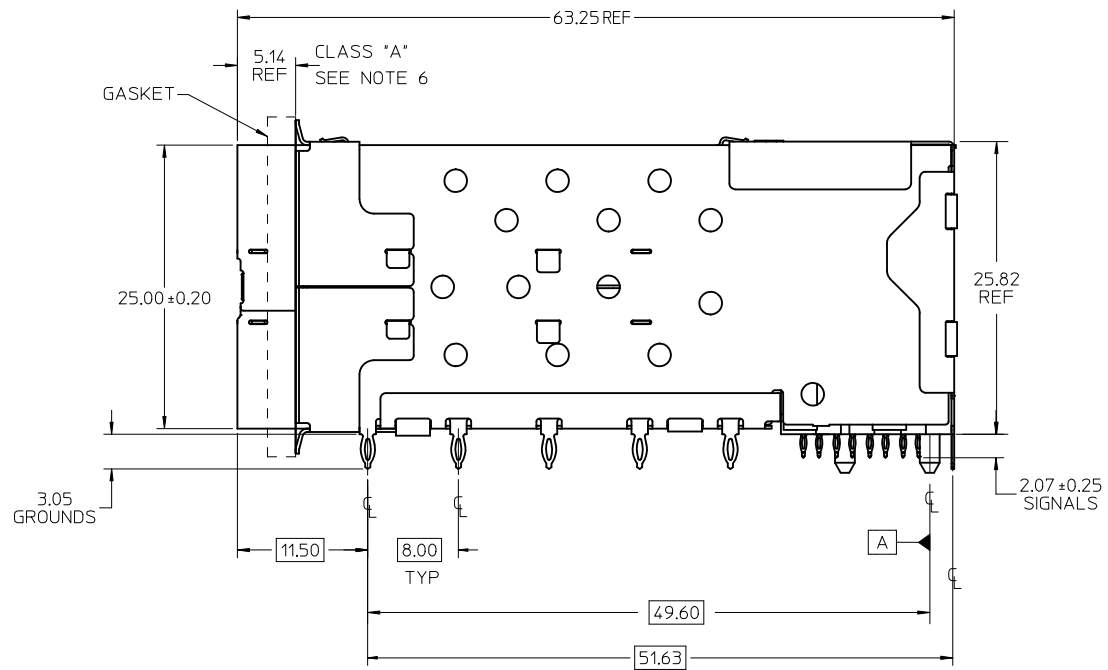
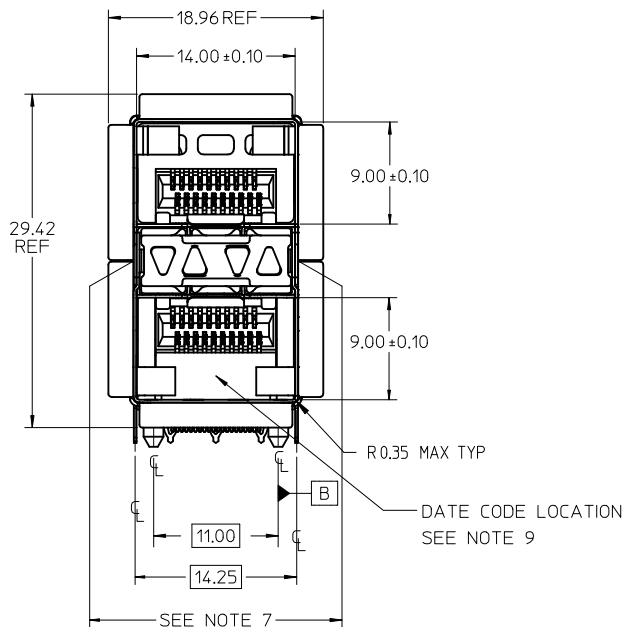

**NOTES**

- MATERIAL:**  
 EMI GASKET: CONDUCTIVE ELASTOMER  
 CAGE: NICKEL SILVER, THICKNESS: 0.25mm  
 CAGE FLANGE: STAINLESS STEEL  
 CONNECTOR HOUSING: GLASS FILLED LIQUID CRYSTAL POLYMER (LCP), UL 94V-0, COLOR: BLACK  
 OVERMOLD TERMINAL HOUSING: GLASS FILLED LIQUID CRYSTAL POLYMER (LCP), UL 94V-0, COLOR: BLACK  
 TERMINALS: TIN BRASS  
 LIGHTPIPES: POLYCARBONITE, 94 V-0, CLEAR  
 LIGHTPIPE HOUSING: ZINC
- FINISHES:**  
 TERMINALS: CONTACT AREA: 0.76 MICROMETERS MINIMUM HARD GOLD OVER 1.27 MICROMETERS MINIMUM NICKEL.  
 COMPLIANT TAIL - TIN/LEAD OPTION: 0.76 TO 1.52 MICROMETERS 90/10 TIN-LEAD OVER 0.76 MICROMETERS MINIMUM NICKEL.  
 COMPLIANT TAIL - TIN OPTION: 0.76 TO 1.52 MICROMETERS TIN OVER 0.76 MICROMETERS MINIMUM NICKEL.  
 LIGHTPIPE HOUSING: 80 MICROMETERS MINIMUM NICKEL OVER COPPER
- REFER TO PS-75310-001 PRODUCT SPEC FOR ALL ELECTRICAL, MECHANICAL, AND ENVIRONMENTAL SPECIFICATIONS.
- LIGHTPIPE PAD LAYOUT IS FOR 0805 LOW-PROFILE LED PACKAGE, FOR OTHER RECOMMENDED LAYOUTS REFER TO MOLEX'S REPORT TS-75310-001.
- REFER TO PK-75462-001 FOR ALL PACKAGING SPECIFICATIONS.
- ALL EXTERIOR SURFACES TO BE CLASS "B" SURFACE EXCEPT THE UNDER SIDE PF THE CAGE WHERE THE PCB WOULD BE LOCATED AND AS NOTED, THE SURFACES TO CONFORM TO THE MOLEX COSMETIC DOC PS-45499-002.
- THE OVERALL CAGE WIDTH AT THE VERTICAL CENTER OF THE FRONT EDGE WILL FALL WITHIN THIS DIMENSION: 14.75+/-0.30 MM. THIS PORTION OF THE CAGE WILL FLEX INWARD AS THE CAGE IS BEING INSERTED INTO THE BEZEL OPENING.
- REFER TO AS-76090-001 FOR HIGH SPEED ROUTING RECOMMENDATIONS.
- DATE CODE LOCATION IS SHOWN ABOVE.  
 DATE CODE FORMAT: DDDY MX A1  
 DDD = DAY OF THE YEAR  
 Y = YEAR  
 MX = MOLEX  
 A = ALPHA CHARACTER - INDICATES MANUFACTURING LINE  
 1 = NUMERIC CHARACTER - INDICATES PRODUCTION SHIFT

PART NUMBER	DESCRIPTION	VIEW	COMPLIANT TAIL PLATING
760900001	4 LIGHT PORTS	SEE PG 2	TIN / LEAD
760900002	INNER 2 PORTS	SEE PG 2	TIN / LEAD
760900003	OUTER 2 PORTS	SEE PG 2	TIN / LEAD
760905001	4 LIGHT PORTS	SEE PG 2	TIN
760905002	INNER 2 PORTS	SEE PG 2	TIN
760905003	OUTER 2 PORTS	SEE PG 2	TIN
760903002	INNER 2 PORTS	SEE PG 2	TIN / LEAD
760906002	INNER 2 PORTS	SEE PG 2	TIN

<b>ADD -6002 ASSEMBLY</b> EC NO: UCP2011-3362 DRW:WOLFE 2011/02/28 CHK:D:SMART APPR:SMILLER 2011/05/09	DESCRIPTION REV:	QUALITY SYMBOLS ▽=0 ▽=0 ▽=0	GENERAL TOLERANCES (UNLESS SPECIFIED) <table border="1"> <tr> <th></th> <th>mm</th> <th>INCH</th> </tr> <tr> <td>4 PLACES</td> <td>± ---</td> <td>± ---</td> </tr> <tr> <td>3 PLACES</td> <td>± ---</td> <td>± ---</td> </tr> <tr> <td>2 PLACES</td> <td>± 0.13</td> <td>± ---</td> </tr> <tr> <td>1 PLACE</td> <td>± 0.25</td> <td>± ---</td> </tr> </table>		mm	INCH	4 PLACES	± ---	± ---	3 PLACES	± ---	± ---	2 PLACES	± 0.13	± ---	1 PLACE	± 0.25	± ---	DIMENSION STYLE <b>MM ONLY</b> DRAWN BY DATE J JANTELEZ 10 01-18-2007 CHECKED BY DATE MSANDBERG 01-18-2007 APPROVED BY DATE KREGNIER 01-18-2007	SCALE <b>3:1</b> DESIGN UNITS <b>METRIC</b> THIRD ANGLE PROJECTION	TITLE <b>STACKED SFP+ 2X1 ASS'Y WITH ELASTOMERIC GASKET AND LIGHTPIPES</b>
			mm	INCH																	
		4 PLACES	± ---	± ---																	
		3 PLACES	± ---	± ---																	
2 PLACES	± 0.13	± ---																			
1 PLACE	± 0.25	± ---																			
DRAFT WHERE APPLICABLE MUST REMAIN WITHIN DIMENSIONS	MATERIAL NO. <b>SEE TABLE</b>	DOCUMENT NO. <b>SD-76090-001</b>	SHEET NO. <b>1 OF 4</b>																		
THIS DRAWING CONTAINS INFORMATION THAT IS PROPRIETARY TO MOLEX INCORPORATED AND SHOULD NOT BE USED WITHOUT WRITTEN PERMISSION				<b>MOLEX INCORPORATED</b>																	

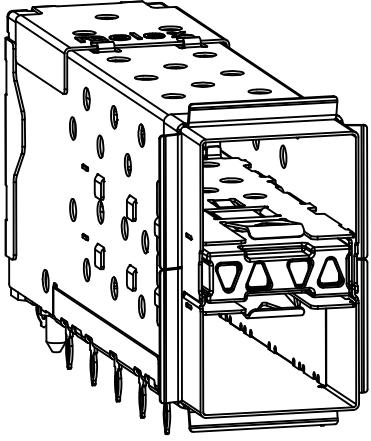

760900001 AND 760905001  
WITH INNER AND OUTER LIGHTPIPES

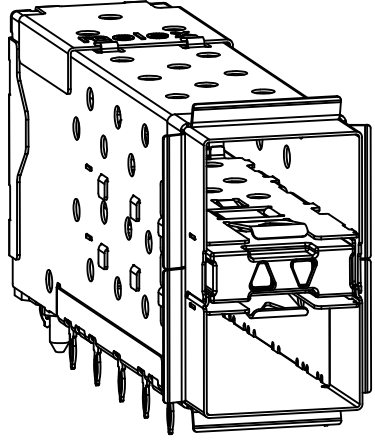

760900002 AND 760905002  
WITH INNER LIGHTPIPES

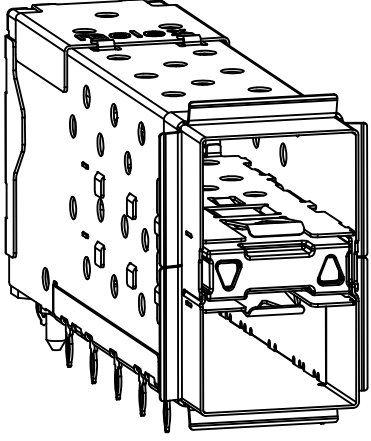

760900003 AND 760905003  
WITH OUTER LIGHTPIPES

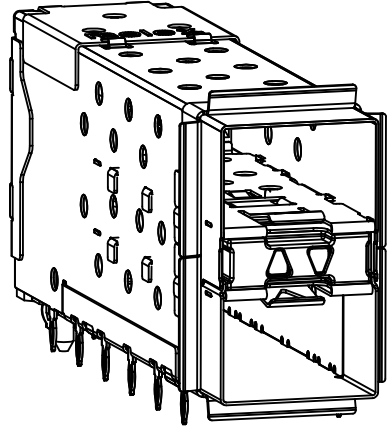

760903002 AND 760906002  
WITH INNER LIGHTPIPES  
& ENHANCED EMI MID-SECTION

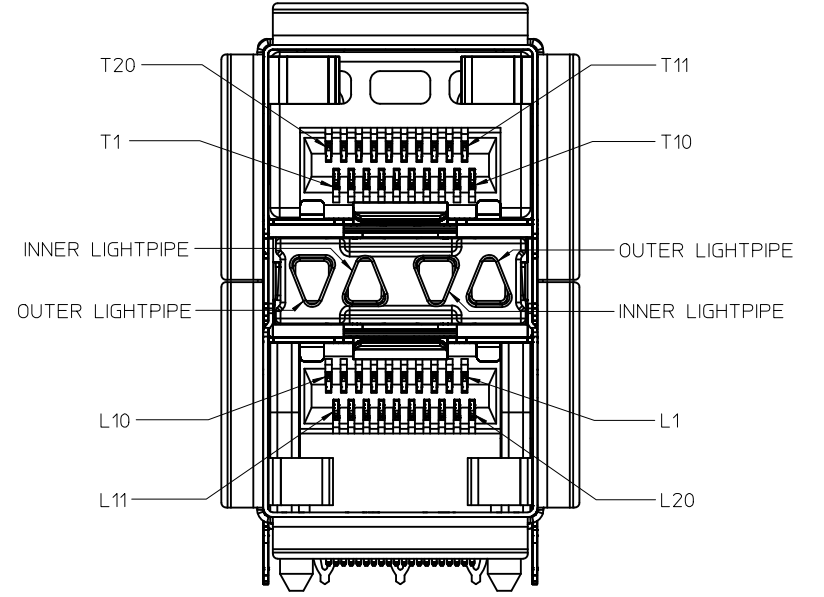

CIRCUIT NUMBERING  
AND LIGHTPIPE  
IDENTIFICATION

SEE SHEET 1 EC NO: UCP2011-3362 DRW:MMOLFE 2011/02/28 CHK:DBSMART APPR:SMILLER 2011/05/09	QUALITY SYMBOLS	GENERAL TOLERANCES (UNLESS SPECIFIED)	DIMENSION STYLE	SCALE	DESIGN UNITS	THIRD ANGLE PROJECTION
	▽=0	mm INCH	MM ONLY	3:1	METRIC	
	▽=0	4 PLACES ± --- ± ---	DRAWN BY DATE	TITLE		
	▽=0	3 PLACES ± --- ± ---	JJANTELEZ10 01-18-2007	STACKED SFP+ 2X1 ASS'Y WITH ELASTOMERIC GASKET AND LIGHTPIPES		
	2 PLACES ± 0.13 ± ---	CHECKED BY DATE	MOLEX INCORPORATED			
	1 PLACE ± 0.25 ± ---	MSANDBERG 01-18-2007	DOCUMENT NO.			
	ANGULAR ± 5 °	APPROVED BY DATE	SD-76090-001			
		KREGNIER 01-18-2007	SHEET NO.			
		MATERIAL NO.	2 OF 4			
		SEE TABLE	THIS DRAWING CONTAINS INFORMATION THAT IS PROPRIETARY TO MOLEX INCORPORATED AND SHOULD NOT BE USED WITHOUT WRITTEN PERMISSION			

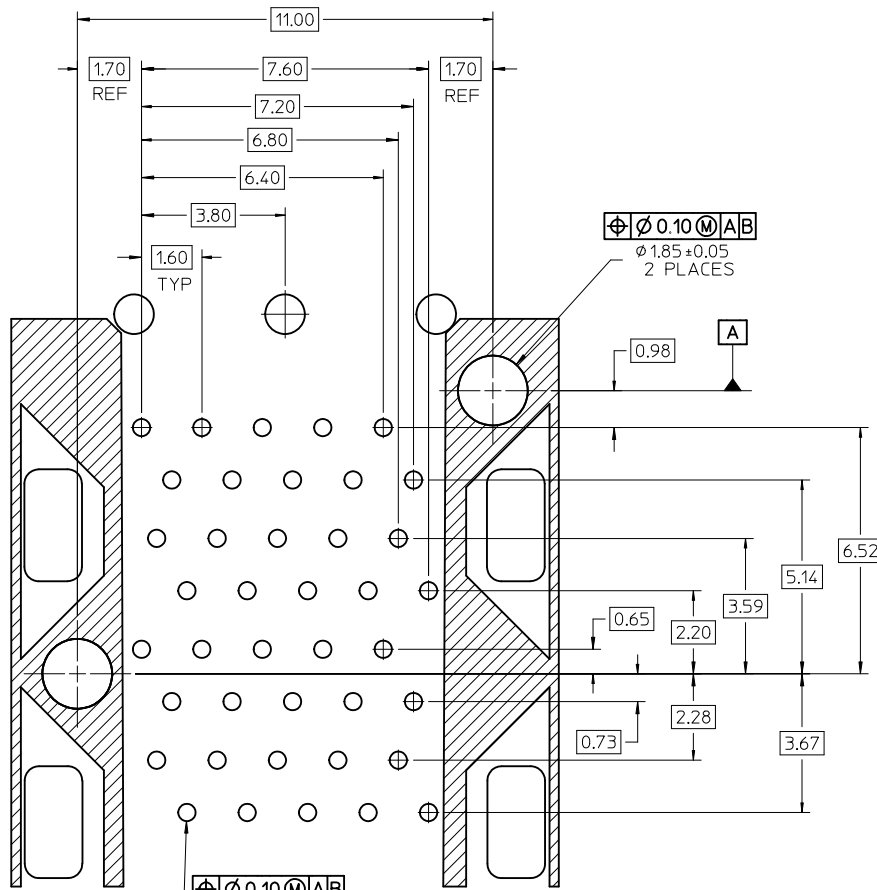

DETAIL A  
SCALE 10:1

$\varnothing 0.10 \text{ M} \text{ AB}$   
 $\varnothing 0.46 \pm 0.05$  TYP  
 ( $\varnothing 0.57$  DRILL)  
 ( $\varnothing 0.88$  PAD)

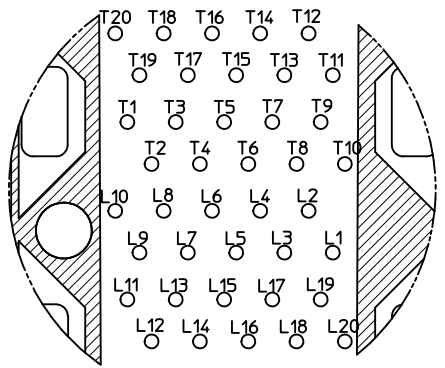

CIRCUIT NUMBERING  
COMPONENT SIDE OF BOARD  
SCALE 10:1

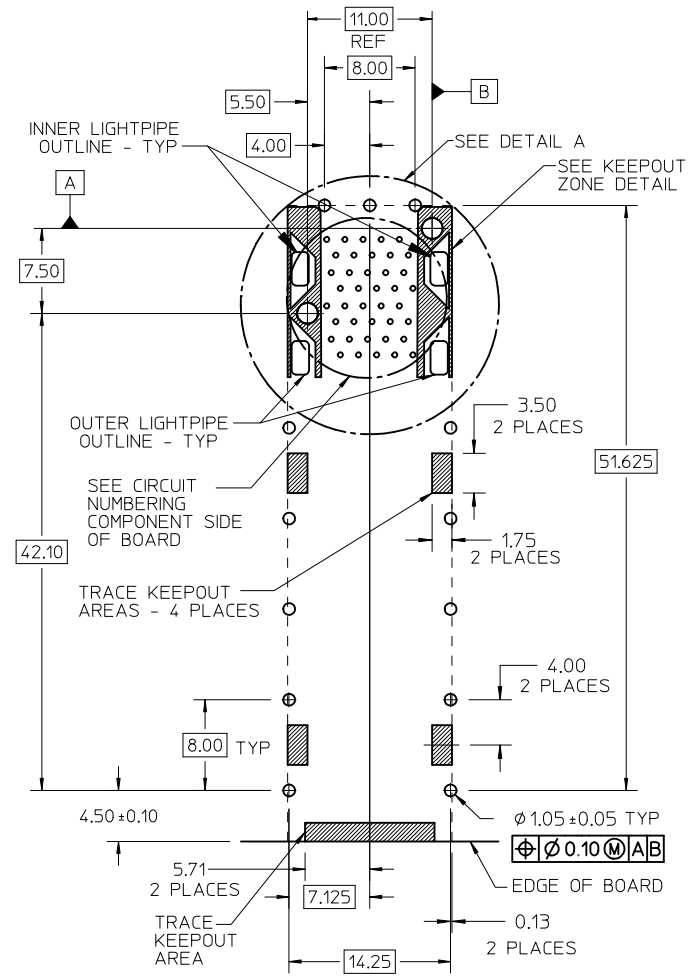

RECOMMENDED PCB LAYOUT - COMPONENT SIDE  
 RECOMMENDED PCB THICKNESS - 2.36 MM (.093 INCH)

THE ENTIRE AREA OF THE CONNECTOR FOOTPRINT  
 TO BE CONSIDERED THE KEEP OUT AREA FOR COMPONENTS  
 (OTHER THAN LIGHTPIPE LED'S)  
 THIS AREA IS INDICATED BY THE DASHED LINE

SEE SHEET 1 EC NO: UCP2011-3362 DRWIN:WOLFE 2011/02/28 CHYKD:BSMART APPR:SMILLER 2011/05/09	QUALITY SYMBOLS $\nabla = 0$ $\nabla = 0$ $\nabla = 0$	GENERAL TOLERANCES (UNLESS SPECIFIED)		DIMENSION STYLE <b>MM ONLY</b>		SCALE <b>3:1</b>	DESIGN UNITS <b>METRIC</b>	THIRD ANGLE PROJECTION
		4 PLACES $\pm$ --- $\pm$ --- 3 PLACES $\pm$ --- $\pm$ --- 2 PLACES $\pm 0.13$ $\pm$ --- 1 PLACE $\pm 0.25$ $\pm$ --- ANGULAR $\pm 5^\circ$	mm INCH --- --- --- --- --- --- --- ---	DRAWN BY JJANTELEZIO	DATE 01-18-2007	CHECKED BY MSANDBERG	DATE 01-18-2007	<b>STACKED SFP+ 2X1 ASS'Y WITH ELASTOMERIC GASKET AND LIGHTPIPES</b>
APPROVED BY KREGNIER	DATE 01-18-2007	<b>MOLEX INCORPORATED</b>			MATERIAL NO. <b>SEE SHEET 1</b>	DOCUMENT NO. <b>SD-76090-001</b>	SHEET NO. <b>3 OF 4</b>	
DRAFT WHERE APPLICABLE MUST REMAIN WITHIN DIMENSIONS		THIS DRAWING CONTAINS INFORMATION THAT IS PROPRIETARY TO MOLEX INCORPORATED AND SHOULD NOT BE USED WITHOUT WRITTEN PERMISSION						



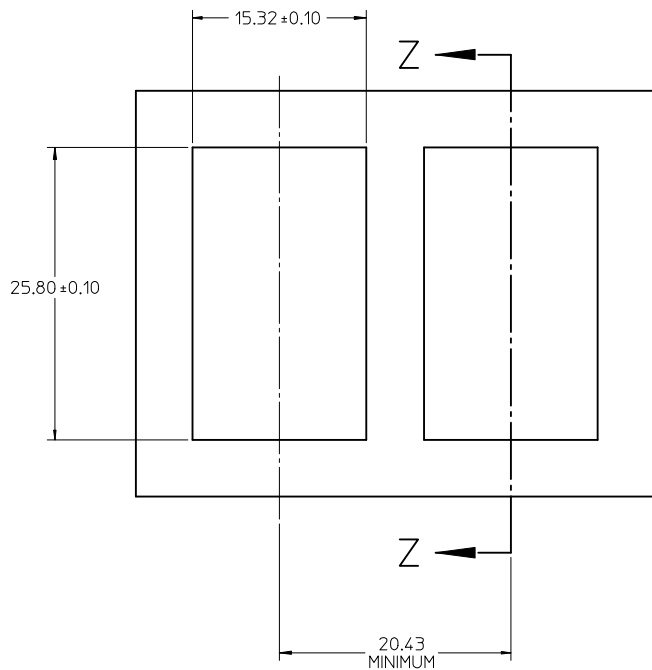

BEZEL CUT-OUT CENTER SPACING DETAIL  
BEZEL THICKNESS 0.8-2.6

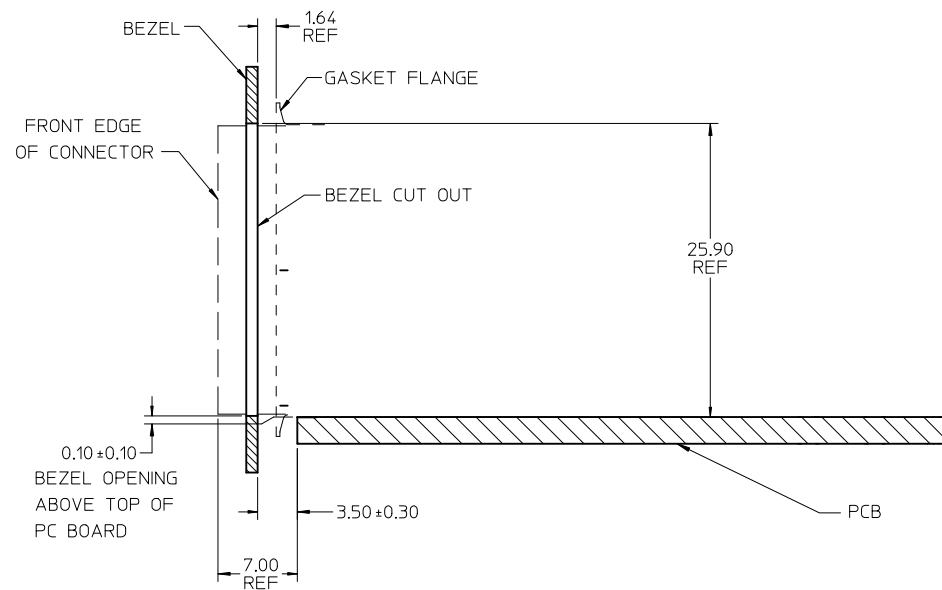

SECTION Z-Z

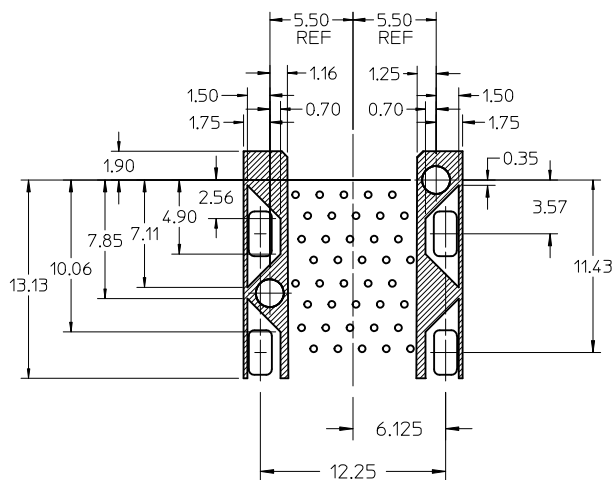

KEEPOUT ZONE DETAIL - LIGHTPIPE LOCATION AND OTHER ZONES  
SCALE 4:1

THE HATCHED AREA IN THIS VIEW INDICATES ZONES THAT ARE OCCUPIED BY THE PLASTIC HOUSING THAT SEATS AGAINST THE PCB AND BY THE VERTICAL METAL CAGE WALL THAT STOPS JUST SHORT OF THE PCB

<b>SEE SHEET 1</b> EC NO: UCP2011-3362 DRAWN BY: DRWINWOLFE CHKD BY: SMART APPR: SMILLER DATE: 2011/02/28 DATE: 2011/05/09	QUALITY SYMBOLS $\nabla = 0$ $\nabla = 0$ $\nabla = 0$	GENERAL TOLERANCES (UNLESS SPECIFIED) <table border="1"> <thead> <tr> <th></th> <th>mm</th> <th>INCH</th> </tr> </thead> <tbody> <tr> <td>4 PLACES</td> <td>± ---</td> <td>± ---</td> </tr> <tr> <td>3 PLACES</td> <td>± ---</td> <td>± ---</td> </tr> <tr> <td>2 PLACES</td> <td>± 0.13</td> <td>± ---</td> </tr> <tr> <td>1 PLACE</td> <td>± 0.25</td> <td>± ---</td> </tr> </tbody> </table>		mm	INCH	4 PLACES	± ---	± ---	3 PLACES	± ---	± ---	2 PLACES	± 0.13	± ---	1 PLACE	± 0.25	± ---	DIMENSION STYLE <b>MM ONLY</b> DRAWN BY: JJANTELEZ DATE: 01-18-2007 CHECKED BY: MSANDBERG DATE: 01-18-2007 APPROVED BY: KREGNIER DATE: 01-18-2007	SCALE <b>3:1</b> DESIGN UNITS <b>METRIC</b> THIRD ANGLE PROJECTION	TITLE <b>STACKED SFP+ 2X1 ASS'Y WITH ELASTOMERIC GASKET AND LIGHTPIPES</b>
		mm	INCH																	
4 PLACES	± ---	± ---																		
3 PLACES	± ---	± ---																		
2 PLACES	± 0.13	± ---																		
1 PLACE	± 0.25	± ---																		
MATERIAL NO. <b>SEE SHEET 1</b> DRAFT WHERE APPLICABLE MUST REMAIN WITHIN DIMENSIONS SIZE <b>C</b> THIS DRAWING CONTAINS INFORMATION THAT IS PROPRIETARY TO MOLEX INCORPORATED AND SHOULD NOT BE USED WITHOUT WRITTEN PERMISSION	DOCUMENT NO. <b>SD-76090-001</b>	SHEET NO. <b>4 OF 4</b>																		