



Chipsmall Limited consists of a professional team with an average of over 10 year of expertise in the distribution of electronic components. Based in Hongkong, we have already established firm and mutual-benefit business relationships with customers from,Europe,America and south Asia,supplying obsolete and hard-to-find components to meet their specific needs.

With the principle of “Quality Parts,Customers Priority,Honest Operation,and Considerate Service”,our business mainly focus on the distribution of electronic components. Line cards we deal with include Microchip,ALPS,ROHM,Xilinx,Pulse,ON,Everlight and Freescale. Main products comprise IC,Modules,Potentiometer,IC Socket,Relay,Connector.Our parts cover such applications as commercial,industrial, and automotives areas.

We are looking forward to setting up business relationship with you and hope to provide you with the best service and solution. Let us make a better world for our industry!



Contact us

Tel: +86-755-8981 8866 Fax: +86-755-8427 6832

Email & Skype: info@chipsmall.com Web: www.chipsmall.com

Address: A1208, Overseas Decoration Building, #122 Zhenhua RD., Futian, Shenzhen, China



PART NUMBER		STATUS	CKTS	DIM A	DIM B	DIM C	DIM D	POWER POS.	DIM E
TIN	TIN FINISH/TREND								
762910008	762910008	NOT TOOLED	8	8.19	4.40	5.65	4.25	-	10.84
762910014	762910014	NOT TOOLED	14	10.44	6.65	7.90	6.50	-	10.84
762910020	762910020	NOT TOOLED	20	12.69	8.90	10.15	8.75	-	10.84
762910026	762910026	NOT TOOLED	26	14.94	11.15	12.40	11.00	-	10.84
762910032	762910032	NOT TOOLED	32	17.19	13.40	14.65	13.25	-	10.84
762910038	762910038	NOT TOOLED	38	19.44	15.60	16.90	15.50	-	10.84
762910044	762910044	NOT TOOLED	44	21.69	17.90	19.15	17.75	-	10.84
762910050	762910050	NOT TOOLED	50	23.94	20.15	21.40	20.00	-	10.84
762910056	762910056	NOT TOOLED	56	26.19	22.40	23.65	22.25	-	10.84
762910062	762910062	NOT TOOLED	62	28.44	24.65	25.90	24.50	-	10.84
762910068	762910068	NOT TOOLED	68	30.69	26.90	28.15	26.75	-	10.84
762910074	762910074	NOT TOOLED	74	32.94	29.15	30.40	29.00	-	10.84
762910080	762910080	NOT TOOLED	80	35.19	31.40	32.65	31.25	-	10.84
762910086	762910086	NOT TOOLED	86	37.44	33.65	34.90	33.50	-	10.84
762910092	762910092	NOT TOOLED	92	39.69	35.90	37.15	35.75	-	10.84
762910098	762910098	NOT TOOLED	98	41.94	38.15	39.40	38.00	-	10.84
762911004	762911004	NOT TOOLED	104	44.19	40.40	41.65	40.25	-	10.84
762911010	762911010	NOT TOOLED	110	46.44	42.65	43.90	42.50	-	10.84
762911016	762911016	NOT TOOLED	116	48.69	44.90	46.15	44.75	-	10.84
762911022	762911022	NOT TOOLED	122	50.94	47.15	48.40	47.00	-	10.84
762911028	762911028	NOT TOOLED	128	53.19	49.40	50.65	49.25	-	10.84
762911034	762911034	NOT TOOLED	134	55.44	51.65	52.90	51.50	-	10.84
762911040	762911040	NOT TOOLED	140	57.69	53.90	55.15	53.75	-	10.84
762911046	762911046	NOT TOOLED	146	59.94	56.15	57.40	56.00	-	10.84
762911052	762911052	NOT TOOLED	152	62.19	58.40	59.65	58.25	-	10.84
762911058	762911058	NOT TOOLED	158	64.44	60.65	61.90	60.50	-	10.84
762911064	762911064	NOT TOOLED	164	66.69	62.90	64.15	62.75	-	10.84
762911070	762911070	NOT TOOLED	170	68.94	65.15	66.40	65.00	-	10.84
762911076	762911076	NOT TOOLED	176	71.19	67.40	68.65	67.25	-	10.84
762911082	762911082	NOT TOOLED	182	73.44	69.65	70.90	69.50	-	10.84
762911088	762911088	NOT TOOLED	188	75.69	71.90	73.15	71.75	-	10.84
762911094	762911094	NOT TOOLED	194	77.94	74.15	75.40	74.00	-	10.84
762911100	762911100	NOT TOOLED	200	80.19	76.40	77.65	76.25	-	10.84
762911106	762911106	NOT TOOLED	206	82.44	78.65	79.90	78.50	-	10.84
762911112	762911112	NOT TOOLED	212	84.69	80.90	82.15	80.75	-	10.84
762911118	762911118	NOT TOOLED	218	86.94	83.15	84.40	83.00	-	10.84
762911124	762911124	NOT TOOLED	224	89.19	85.40	86.65	85.25	-	10.84
762911130	762911130	NOT TOOLED	230	91.44	87.65	88.90	87.50	-	10.84
762911136	762911136	NOT TOOLED	236	93.69	89.90	91.15	89.75	-	10.84
762911142	762911142	NOT TOOLED	242	95.94	92.15	93.40	92.00	-	10.84
762911148	762911148	NOT TOOLED	248	98.19	94.40	95.65	94.25	-	10.84
762911154	762911154	NOT TOOLED	254	100.44	96.65	97.90	96.50	-	10.84

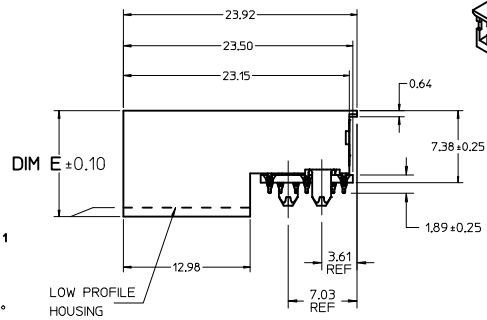
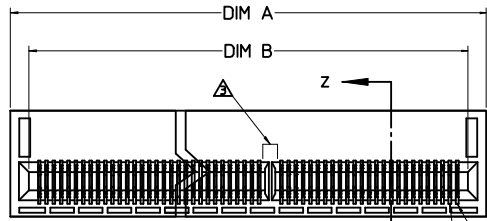
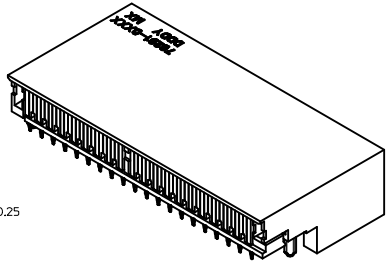
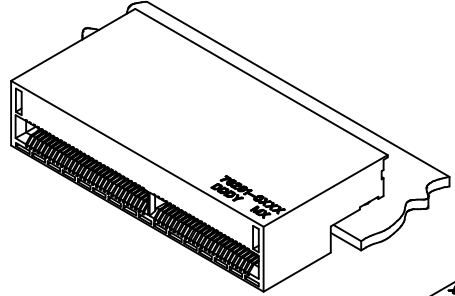
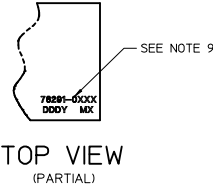

LOW PROFILE

LOW PROFILE HOUSING

100X45° CHAMFER ALL AROUND

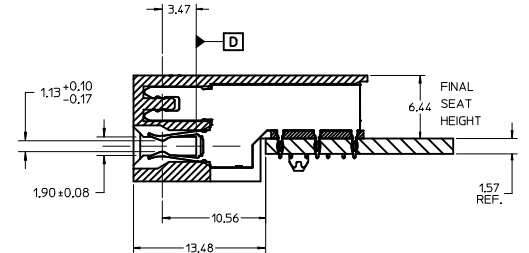
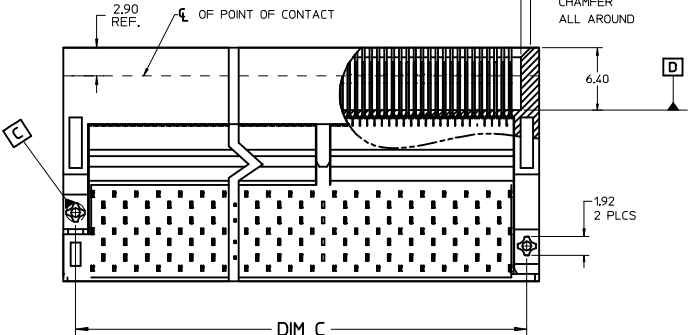

SECTION Z-Z

- NOTES:
- MATERIAL - CONNECTOR HOUSING - GLASS FILLED LCP, 94V-0, BLACK OVERMOLDING ON TERMINALS: GLASS FILLED LCP, 94V-0, BLACK TERMINALS: COPPER ALLOY, SPRING TEMPER
 - TERMINAL FINISH: CONTACT AREA: .75µm HARD GOLD OVER 3.8µm MIN NICKEL. COMPLIANT AREA: .75-1.50µm TIN OVER .75µm - 1.50µm NICKEL.
 - FOR CIRCUIT SIZES GREATER THAN 170, A CENTER ALIGNMENT KEY WILL BE USED.
 - REFER TO PS-76291-001 PRODUCT SPEC FOR ALL ELECTRICAL, MECHANICAL, AND ENVIRONMENTAL SPECIFICATIONS.
 - REFER TO PK-76291-001 FOR ALL PACKAGING SPECIFICATIONS.
 - REFER TO AS-76291-001 FOR BOARD APPLICATION INFORMATION.
 - MODULE BOARD CONTACT PAD PLATING TO BE .76µm MIN HARD GOLD OVER 2.54µm MIN NICKEL
 - MODULE BOARD CONTACT PAD SURFACE ROUGHNESS NOT TO EXCEED Ra 0.2µm.
 - PART TO BE LASER MARKED WITH PART NUMBER, WHERE XXX IS THE CIRCUIT SIZE OR POWER WAFER OPTION, MANUFACTURING FACILITY, AND DATE CODE IN THE FORMAT OF: DAY OF THE YEAR AND LAST DIGIT OF THE YEAR: DDDY

Rev: DIM E LowProfile EC NO: LCP2014-4718 DRWNS: B061E CHKD: APPR: MBANKIS 2013/11/19 2014/05/12	QUALITY SYMBOLS ∇=0 ∇=0 ∇=0	GENERAL TOLERANCES (UNLESS SPECIFIED): mm INCH 4 PLACES +--- +--- 3 PLACES +--- +--- 2 PLACES +0.13 +--- 1 PLACE +0.25 +--- 0 PLACE +--- +--- ANGULAR ±1/2° DRAFT WHERE APPLICABLE MUST REMAIN WITHIN DIMENSIONS	DIMENSION STYLE MM ONLY SCALE 4:1 DESIGN UNITS METRIC THIRD ANGLE PROJECTION	DRAWN BY HAVERY DATE 2010/11/16 CHECKED BY DATE APPROVED BY MBANKIS DATE 2010/11/17	TITLE .75 COPLANAR CONNECTOR GENERAL SALES DRAWING molex DOCUMENT NO. SD-76291-001	SHEET NO. 1 OF 3
	THIS DRAWING CONTAINS INFORMATION THAT IS PROPRIETARY TO MOLEX INCORPORATED AND SHOULD NOT BE USED WITHOUT WRITTEN PERMISSION					

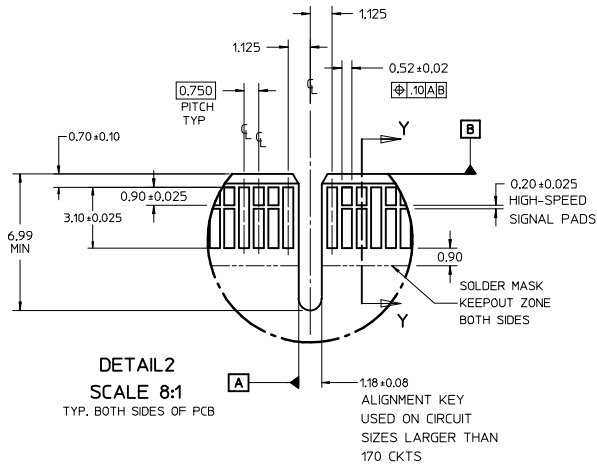
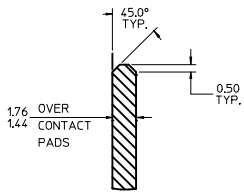
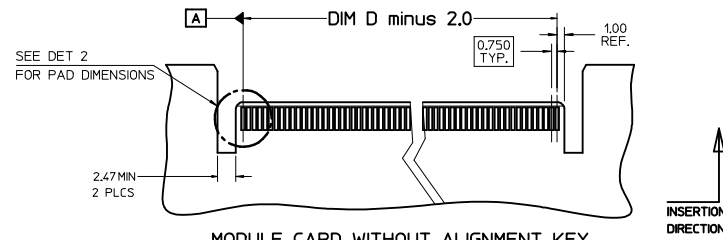
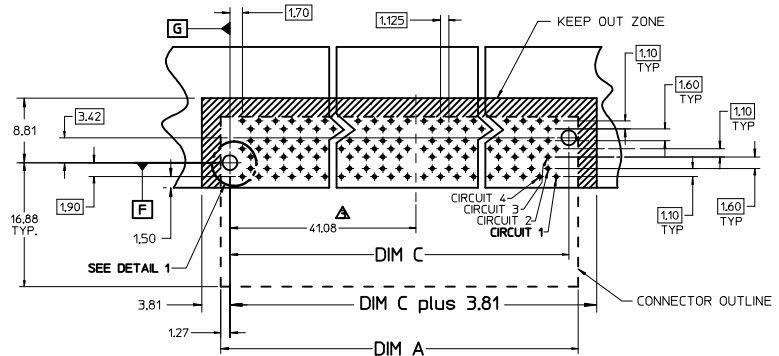
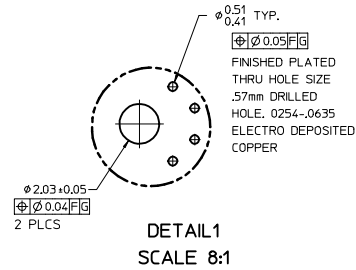

SEE SHEET 1 EEC NO: UCP2014-4718 DRAWNS: SPOGIEL 2013/11/19 CHKD: APPR: MBANKIS 2014/05/12	QUALITY SYMBOLS ∇=0 ∇=0 ∇=0	GENERAL TOLERANCES (UNLESS SPECIFIED) DIMENSION STYLE MM ONLY	DIMENSION STYLE MM ONLY DRAWN BY DATE HAVERY 2010/11/16 CHECKED BY DATE APPROVED BY DATE MBANKIS 2010/11/17	SCALE 4:1 DESIGN UNITS METRIC	THIRD ANGLE PROJECTION
	ANGULAR ±1/2° DRAFT WHERE APPLICABLE MUST REMAIN WITHIN DIMENSIONS	MATERIAL NO. SEE CHART	DOCUMENT NO. SD-76291-001	TITLE .75 COPLANAR CONNECTOR GENERAL SALES DRAWING	SHEET NO. 2 OF 3

PCB PIN-OUT ASSIGNMENTS

(TOP SIDE OF BOARD SHOWN)

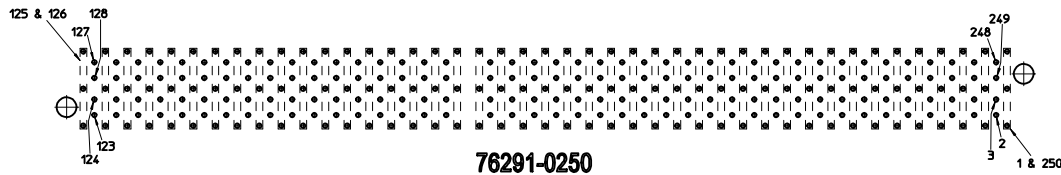
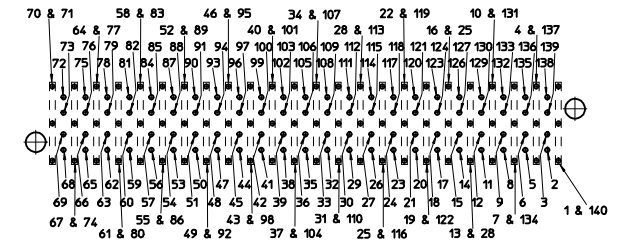
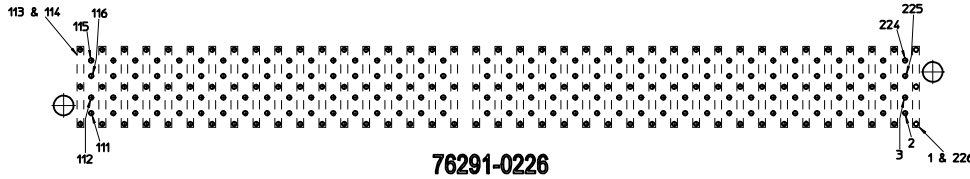
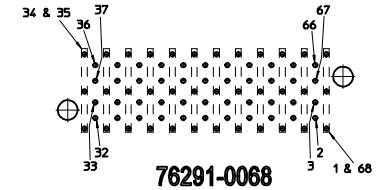
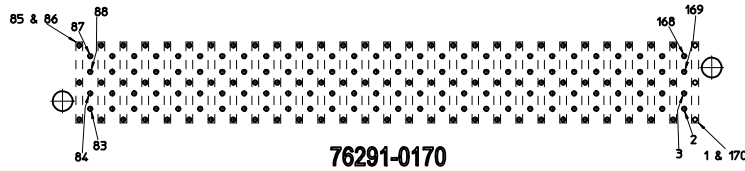
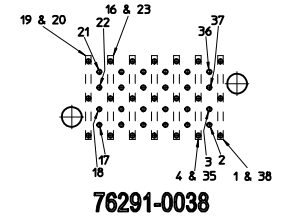
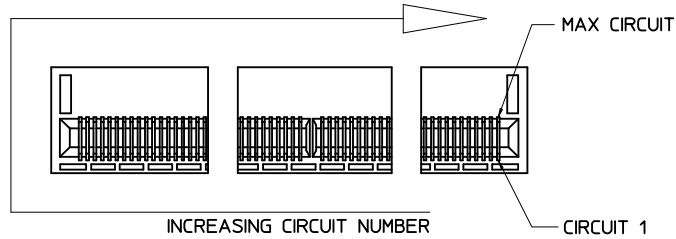

FRONT EDGE OF PCB

NOTES ON CIRCUIT DESIGNATIONS:

1. CIRCUIT 1 STARTS AT LOWER RIGHT HAND CORNER AND INCREASES TO THE LEFT ACROSS THE BOTTOM AND INCREASES TO THE RIGHT ACROSS THE TOP.
2. THERE IS NOT A 1:1 CORRESPONDENCE BETWEEN THE CIRCUIT NUMBER AND THE TAIL HOLE LOCATIONS. EACH GROUND HAS TWO CONTACTS AND THREE TAILS. THE BOXES AROUND THE THREE VERTICAL HOLES INDICATE THE UPPER AND LOWER GROUND CONTACTS SHARE THE THREE TAIL HOLE LOCATIONS.

SEE SHEET 1 EC NO: UCP2014-4718 DRWNSB01EL 2013/11/19 CHKD: APPROBANKIS 2014/05/12	QUALITY SYMBOLS	GENERAL TOLERANCES (UNLESS SPECIFIED)	DIMENSION STYLE	SCALE	DESIGN UNITS	THIRD ANGLE PROJECTION
	▽=0	4 PLACES ±--- INCH	MM ONLY	4:1	METRIC	☉
	▽=0	3 PLACES ±---	DRAWN BY DATE	TITLE		
	▽=0	2 PLACES ±0.13	HAVERY 2010/11/16	.75 COPLANAR CONNECTOR GENERAL SALES DRAWING		
	1 PLACE ±0.25	0 PLACE ±---	CHECKED BY DATE			
	ANGULAR ±1/2°	DRAFT WHERE APPLICABLE MUST REMAIN WITHIN DIMENSIONS	APPROVED BY DATE			
			MBANKIS 2010/11/17			
			MATERIAL NO.	DOCUMENT NO.	SHEET NO.	
			SEE CHART	SD-76291-001	3 OF 3	
			THIS DRAWING CONTAINS INFORMATION THAT IS PROPRIETARY TO MOLEX INCORPORATED AND SHOULD NOT BE USED WITHOUT WRITTEN PERMISSION			