



Chipsmall Limited consists of a professional team with an average of over 10 year of expertise in the distribution of electronic components. Based in Hongkong, we have already established firm and mutual-benefit business relationships with customers from,Europe,America and south Asia,supplying obsolete and hard-to-find components to meet their specific needs.

With the principle of “Quality Parts,Customers Priority,Honest Operation,and Considerate Service”,our business mainly focus on the distribution of electronic components. Line cards we deal with include Microchip,ALPS,ROHM,Xilinx,Pulse,ON,Everlight and Freescale. Main products comprise IC,Modules,Potentiometer,IC Socket,Relay,Connector.Our parts cover such applications as commercial,industrial, and automotives areas.

We are looking forward to setting up business relationship with you and hope to provide you with the best service and solution. Let us make a better world for our industry!



Contact us

Tel: +86-755-8981 8866 Fax: +86-755-8427 6832

Email & Skype: info@chipsmall.com Web: www.chipsmall.com

Address: A1208, Overseas Decoration Building, #122 Zhenhua RD., Futian, Shenzhen, China



08010100 BATTERY DISCONNECT SWITCHES

300A • SPST • IP65 • M10 Studs • 360° rotation



Description

Battery switch with a metal body, interchangeable with other products currently available on the market that share a similar footprint. The metal body of this battery switch is particularly robust and designed for use on agricultural machinery, construction equipment and commercial vehicles.

Features/Benefits

- 300A continuous current rating
- Fixed handle.
- Highly visible bright red handle.
- The “V contacts” position reduces risk of arcing
- Waterproof IP65

Mounting Diagram

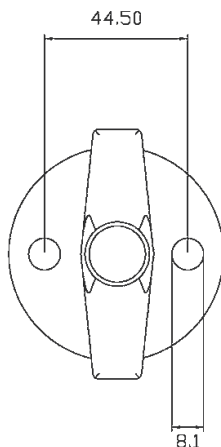

Specifications

Max Operating Voltage:	24V DC
Max Continuous Current:	300A
Intermittent Current:	1000A at 10 sec
Operating Temp:	-40 °C to +80 °C
Ingress Protection:	IP65
Contacts:	Copper
Terminals:	M10 (brass)

Applications

- Heavy trucks
- Commercial vehicles
- Buses
- Agricultural

Web Resources

Download 2D print and technical resources at:
littelfuse.com/ManualBatterySwitches

Electrical Diagram

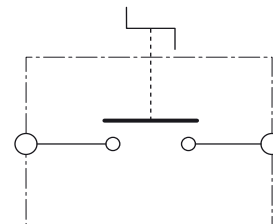

Ordering Information

PART NUMBER	VOLTAGE	AMPERAGE	CIRCUITRY	MOUNTING	INGRESS	TERMINAL NUTS	NOTES
08010100	12-24V DC	300A	SPST	Through-Hole	IP65	M10 brass	Fixed handle

08010100 BATTERY DISCONNECT SWITCHES

Dimensions in millimeters

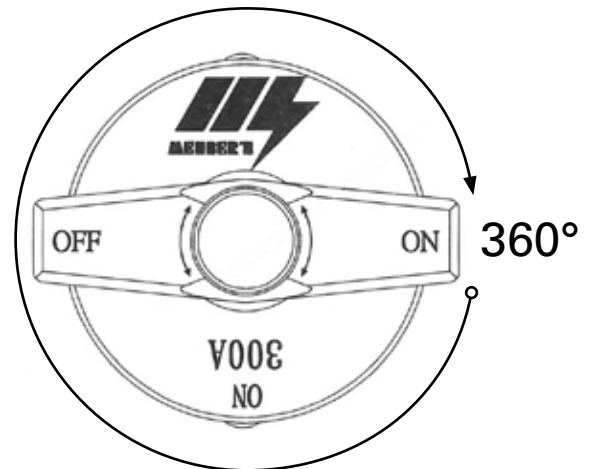
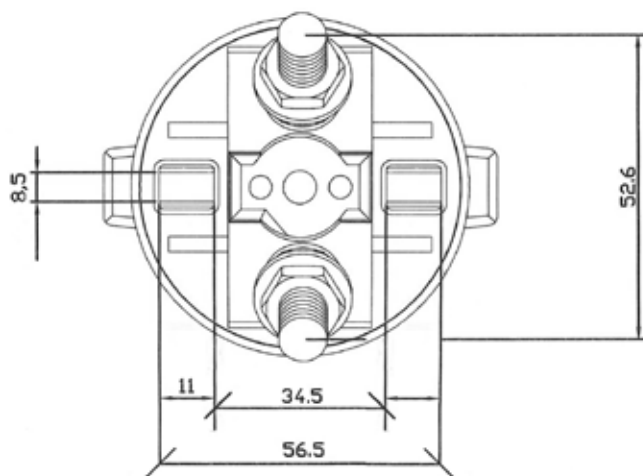
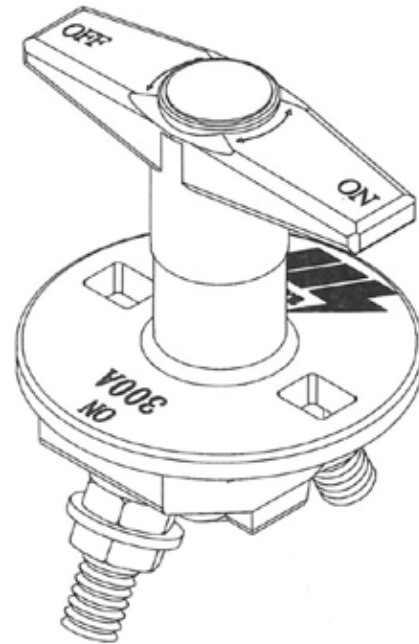
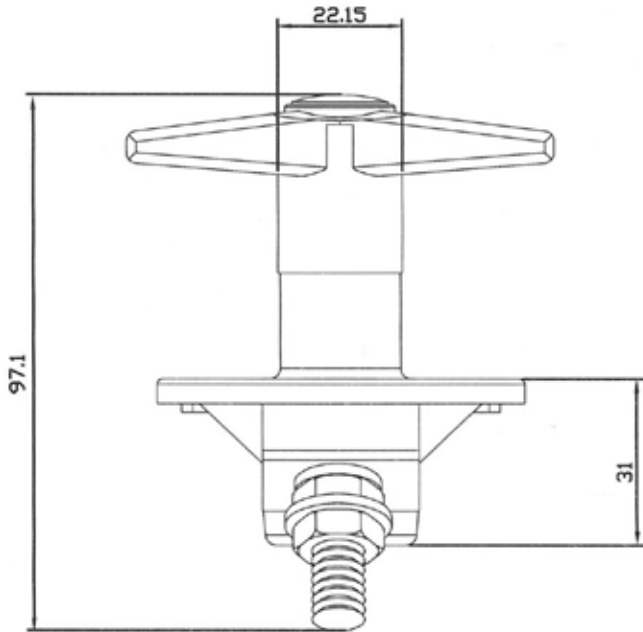

Visit Littelfuse.com for the most up-to-date product information. Littelfuse reserves the right to make product changes, without notice. Material in this document is as accurate as known at the time of publication.