



Chipsmall Limited consists of a professional team with an average of over 10 year of expertise in the distribution of electronic components. Based in Hongkong, we have already established firm and mutual-benefit business relationships with customers from,Europe,America and south Asia,supplying obsolete and hard-to-find components to meet their specific needs.

With the principle of "Quality Parts,Customers Priority,Honest Operation,and Considerate Service",our business mainly focus on the distribution of electronic components. Line cards we deal with include Microchip,ALPS,ROHM,Xilinx,Pulse,ON,Everlight and Freescale. Main products comprise IC,Modules,Potentiometer,IC Socket,Relay,Connector.Our parts cover such applications as commercial,industrial, and automotives areas.

We are looking forward to setting up business relationship with you and hope to provide you with the best service and solution. Let us make a better world for our industry!



## Contact us

Tel: +86-755-8981 8866 Fax: +86-755-8427 6832

Email & Skype: info@chipsmall.com Web: www.chipsmall.com

Address: A1208, Overseas Decoration Building, #122 Zhenhua RD., Futian, Shenzhen, China



## Snap-on frame - CES-B16-SF-PLBK - 0801651

Please be informed that the data shown in this PDF Document is generated from our Online Catalog. Please find the complete data in the user's documentation. Our General Terms of Use for Downloads are valid (<http://phoenixcontact.com/download>)



Size B16 snap-on frame including integrated mounting panel seal, for accommodating CES-B16-HFFS-PLBK or CES-B16-SFFS-PLBK sealing frames

### Product Description

Snap-on frame, medium



### Key Commercial Data

Packing unit	1 pc
Weight per Piece (excluding packing)	56.0 g
Custom tariff number	39174000
Country of origin	Germany

### Technical data

#### Dimensions

Length	128 mm
Width	64 mm
Height	38 mm

#### Ambient conditions

Degree of protection	IP54
Ambient temperature (operation)	-20 °C ... 80 °C

#### General

Product description	Snap-on frame, medium
Frame type	Snap-on frame
Material	PA
Flammability rating according to UL 94	V0
Color	black
Installation instructions	M4 mounting screw. 1.8 Nm torque

# Snap-on frame - CES-B16-SF-PLBK - 0801651

## Technical data

### General

	A video tutorial on how to assemble the product can be found in the Downloads area, in the Video category.
	Leak-tightness is guaranteed with underwall and perpendicular mounting.

### Standards and Regulations

Flammability rating according to UL 94	V0
--	----

## Classifications

### eCl@ss

eCl@ss 4.0	27081002
eCl@ss 4.1	27081002
eCl@ss 5.0	27081002
eCl@ss 5.1	27081002
eCl@ss 6.0	27081002
eCl@ss 7.0	27081002
eCl@ss 8.0	27069220

### ETIM

ETIM 3.0	EC000451
ETIM 4.0	EC000451
ETIM 5.0	EC000451

### UNSPSC

UNSPSC 6.01	30212109
UNSPSC 7.0901	39121708
UNSPSC 11	39121708
UNSPSC 12.01	39121708
UNSPSC 13.2	39121708

## Approvals

### Approvals

---

#### Approvals

GL

---

#### Ex Approvals

# Snap-on frame - CES-B16-SF-PLBK - 0801651

## Approvals

Approvals submitted

## Approval details

GL

## Drawings

Dimensional drawing

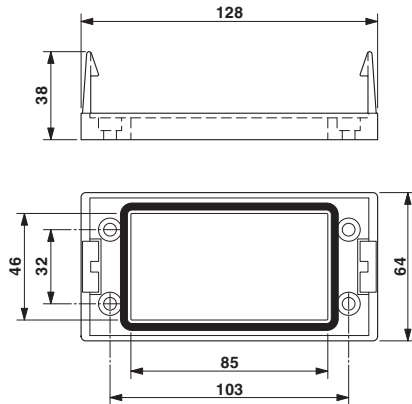

Dimensional drawing

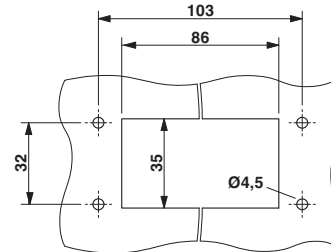

Panel cutout

## Dimensional drawing