



Chipsmall Limited consists of a professional team with an average of over 10 year of expertise in the distribution of electronic components. Based in Hongkong, we have already established firm and mutual-benefit business relationships with customers from,Europe,America and south Asia,supplying obsolete and hard-to-find components to meet their specific needs.

With the principle of “Quality Parts,Customers Priority,Honest Operation,and Considerate Service”,our business mainly focus on the distribution of electronic components. Line cards we deal with include Microchip,ALPS,ROHM,Xilinx,Pulse,ON,Everlight and Freescale. Main products comprise IC,Modules,Potentiometer,IC Socket,Relay,Connector.Our parts cover such applications as commercial,industrial, and automotives areas.

We are looking forward to setting up business relationship with you and hope to provide you with the best service and solution. Let us make a better world for our industry!



Contact us

Tel: +86-755-8981 8866 Fax: +86-755-8427 6832

Email & Skype: info@chipsmall.com Web: www.chipsmall.com

Address: A1208, Overseas Decoration Building, #122 Zhenhua RD., Futian, Shenzhen, China



End clamp - CLIPFIX 35 WH - 0802723

Please be informed that the data shown in this PDF Document is generated from our Online Catalog. Please find the complete data in the user's documentation. Our General Terms of Use for Downloads are valid (<http://phoenixcontact.com/download>)



Quick mounting end clamp, for 35 mm NS 35/7,5 or NS 35/15 DIN rail, can be fitted with ZB 8 and ZB 8/27 zack marker strips, KLM 2 and KLM terminal strip markers, width: 9.5 mm, color: white

The illustration shows the version in gray

Product Features

- ✓ Phoenix Contact has engineered its CLIPFIX end brackets to maintain a secure grip on the various DIN rail systems
- ✓ Design width of just 9.5 mm
- ✓ Large-surface labeling



Key Commercial Data

| | |
|--------------------------------------|----------|
| Packing unit | 1 pc |
| Minimum order quantity | 50 pc |
| Weight per Piece (excluding packing) | 6.4 g |
| Custom tariff number | 85389099 |
| Country of origin | Poland |

Technical data

Dimensions

| | |
|------------|--------|
| Length (b) | 57 mm |
| Width (a) | 9.5 mm |

General

| | |
|--|-------|
| Color | white |
| Flammability rating according to UL 94 | V2 |
| Material | PA |

Standards and Regulations

| | |
|--|----|
| Flammability rating according to UL 94 | V2 |
|--|----|

End clamp - CLIPFIX 35 WH - 0802723

Classifications

eCl@ss

| | |
|------------|----------|
| eCl@ss 4.0 | 27141199 |
| eCl@ss 4.1 | 27141199 |
| eCl@ss 5.0 | 27141135 |
| eCl@ss 5.1 | 27141135 |
| eCl@ss 6.0 | 27141135 |
| eCl@ss 7.0 | 27141135 |
| eCl@ss 8.0 | 27141135 |

ETIM

| | |
|----------|----------|
| ETIM 3.0 | EC001041 |
| ETIM 4.0 | EC001041 |
| ETIM 5.0 | EC001041 |

UNSPSC

| | |
|---------------|----------|
| UNSPSC 6.01 | 30212109 |
| UNSPSC 7.0901 | 39121708 |
| UNSPSC 11 | 39121708 |
| UNSPSC 12.01 | 39121708 |
| UNSPSC 13.2 | 39121708 |

Drawings

End clamp - CLIPFIX 35 WH - 0802723

Dimensional drawing

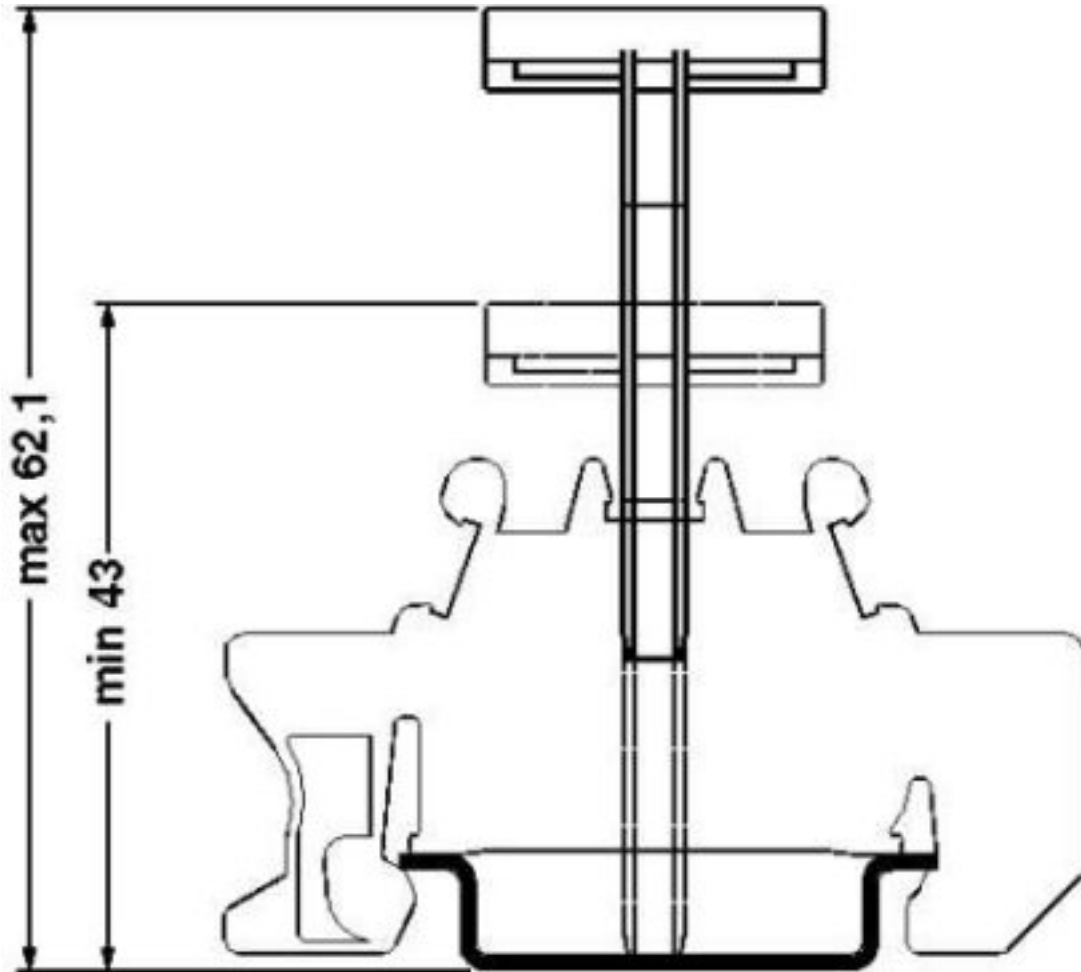

End clamp - CLIPFIX 35 WH - 0802723

Dimensional drawing

