



Chipsmall Limited consists of a professional team with an average of over 10 year of expertise in the distribution of electronic components. Based in Hongkong, we have already established firm and mutual-benefit business relationships with customers from,Europe,America and south Asia,supplying obsolete and hard-to-find components to meet their specific needs.

With the principle of "Quality Parts,Customers Priority,Honest Operation,and Considerate Service",our business mainly focus on the distribution of electronic components. Line cards we deal with include Microchip,ALPS,ROHM,Xilinx,Pulse,ON,Everlight and Freescale. Main products comprise IC,Modules,Potentiometer,IC Socket,Relay,Connector.Our parts cover such applications as commercial,industrial, and automotives areas.

We are looking forward to setting up business relationship with you and hope to provide you with the best service and solution. Let us make a better world for our industry!



## Contact us

Tel: +86-755-8981 8866 Fax: +86-755-8427 6832

Email & Skype: info@chipsmall.com Web: www.chipsmall.com

Address: A1208, Overseas Decoration Building, #122 Zhenhua RD., Futian, Shenzhen, China



NOTES:

1. MATERIALS AND FINISHES:  
 BODY - BRASS  
 CONTACT - BRASS  
 OUTER CONTACT - BRASS  
 INSULATOR - PTFE
2. MECHANICAL:  
 A. DURABILITY: 500 CYCLES MIN.  
 B. TEMPERATURE RANGE: -65° C TO +165° C
3. PACKAGING:  
 A. QUANTITY: SINGLE PACK  
 B. MARKING: BAG TO BE MARKED  
 "AMPHENOL, 82-4426, AND DATE CODE"
4. SHOWS CABLE ENTRY DIMENSIONS.
5. CUSTOMER NOTE: SOLDER CONTACT TO CABLE  
 CRIMP WITH AMPHENOL TOOL 227-944(M22520/5-01)  
 & DIE SET 227-1221-25 CAVITY B(M22520/5-25 CLOSURE B). (.100 HEX)
6. CRIMP WITH AMPHENOL TOOL 227-944(M22520/5-01)  
 & DIE SET 227-1221-25 CAVITY A(M22520/5-25 CLOSURE A). (.420 HEX)

82-4426		REVISIONS			
DRAWING NO.	REV	DESCRIPTION	DATE	ECO	APPR
THIRD ANGLE PROJ.	--	RELEASE TO MFG.	-----	-----	-----
	R	REDRAWN IN PRO/E, ADDED COD	1/14/13	48616	CPM
	T	SEE SHEET 1	4/16/13	49480	CPM

# MIL-C-39012 INSPECTION

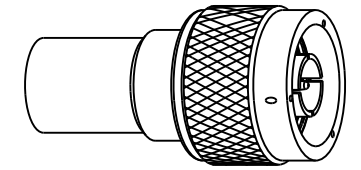

SCALE 1.000

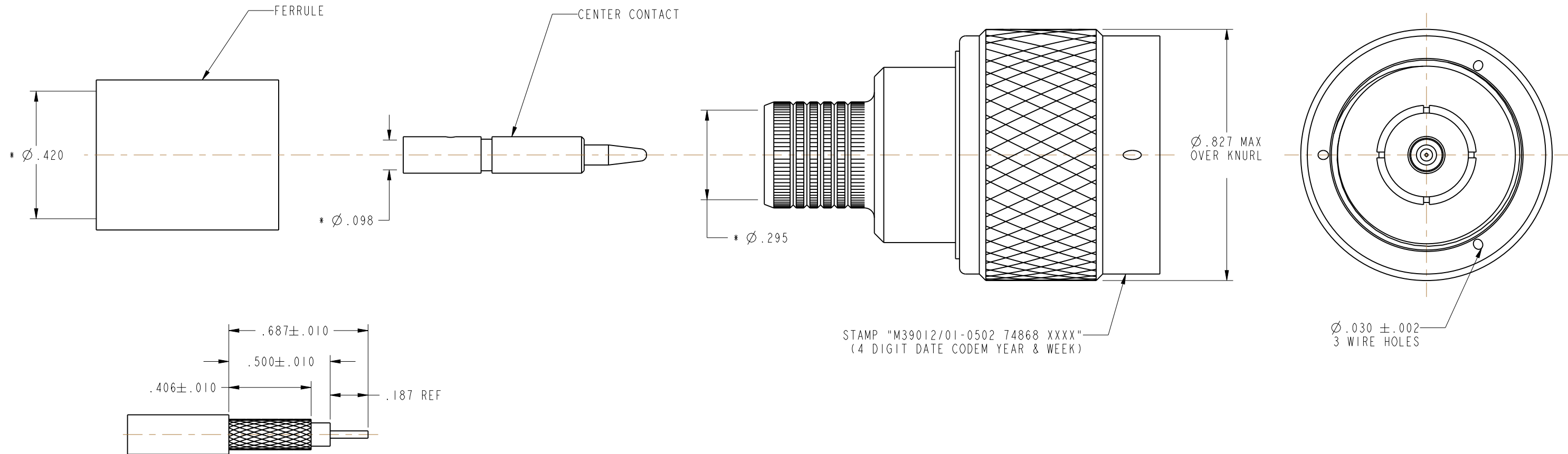

## RECOMMENDED CABLE STRIPPING DIMENSIONS

## CUSTOMER OUTLINE DRAWING

ALL OTHER SHEETS ARE FOR INTERNAL USE ONLY

UNLESS OTHERWISE SPECIFIED, DIMENSIONS ARE IN INCHES AND TOLERANCES ARE: 2 PLACE DECIMAL ±.015 (0,381 mm) 3 PLACE DECIMAL ±.005 (0,127 mm) ANGLES ± 1°	MATERIAL	DRAWN C. McGRATH	DATE 12/12/12	TITLE TYPE "N" PLUG MIL-CRIMP (CATEGORY D) RG 8 & 213/U	Amphenol RF Danbury, CT, USA Tainan, Taiwan Shenzhen, China www.amphenolrf.com		
	NOTICE - These drawings, specifications, or other data (1) are, and remain the property of Amphenol Corp. (2) must be returned upon request; and (3) are confidential and not to be disclosed to any person other than those to whom they are given by Amphenol Corp. The furnishing of these drawings, specifications, or other data by Amphenol Corp., or to any other person to anyone for any purpose is not to be regarded by implication or otherwise in any manner licensing, granting rights or permitting such holder or any other person to manufacture, use or sell any product, process or design, patented or otherwise, that may in any way be related to or disclosed by said drawings, specifications, or other data.	REFERENCE MIL-C-39012/01-0502	ENGINEER K. CAPOZZI		DATE 12/12/12	APPROVED K. CAPOZZI	DATE 1/14/13
		CAD FILE		CODE ID 74868	DWG SIZE B	DRAWING NO. 82-4426	REV T