



Chipsmall Limited consists of a professional team with an average of over 10 year of expertise in the distribution of electronic components. Based in Hongkong, we have already established firm and mutual-benefit business relationships with customers from,Europe,America and south Asia,supplying obsolete and hard-to-find components to meet their specific needs.

With the principle of “Quality Parts,Customers Priority,Honest Operation,and Considerate Service”,our business mainly focus on the distribution of electronic components. Line cards we deal with include Microchip,ALPS,ROHM,Xilinx,Pulse,ON,Everlight and Freescale. Main products comprise IC,Modules,Potentiometer,IC Socket,Relay,Connector.Our parts cover such applications as commercial,industrial, and automotives areas.

We are looking forward to setting up business relationship with you and hope to provide you with the best service and solution. Let us make a better world for our industry!



Contact us

Tel: +86-755-8981 8866 Fax: +86-755-8427 6832

Email & Skype: info@chipsmall.com Web: www.chipsmall.com

Address: A1208, Overseas Decoration Building, #122 Zhenhua RD., Futian, Shenzhen, China



NOTES:

- 1. MATERIALS AND FINISHES:
 BODY - BRASS, NICKEL PLATED.
 CONTACT - BERYLLIUM COPPER, SILVER PLATED
 INSULATOR - PTFE, NATURAL
- 2. ELECTRICAL:
 A. IMPEDANCE: 50 OHM
- 3. MECHANICAL:
 A. DURABILITY: 500 CYCLES MIN.
 B. TEMPERATURE RANGE: -65°C TO +165°C

THIRD ANGLE PROJ.

REVISIONS

REV	DESCRIPTION	DATE	ECO	APPR
	OFFICIAL ENG.RELEASE TO MFG.			
W	STAMP "AMPHENOL" WAS "74868" & ADDED COD\RD-DM12092001R3	23-Oct-12	49079	DH

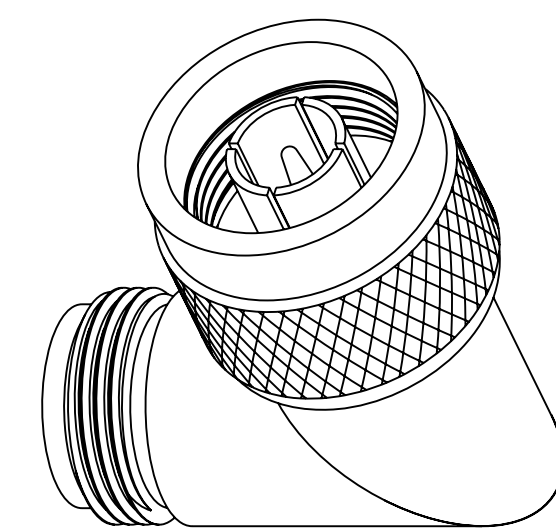
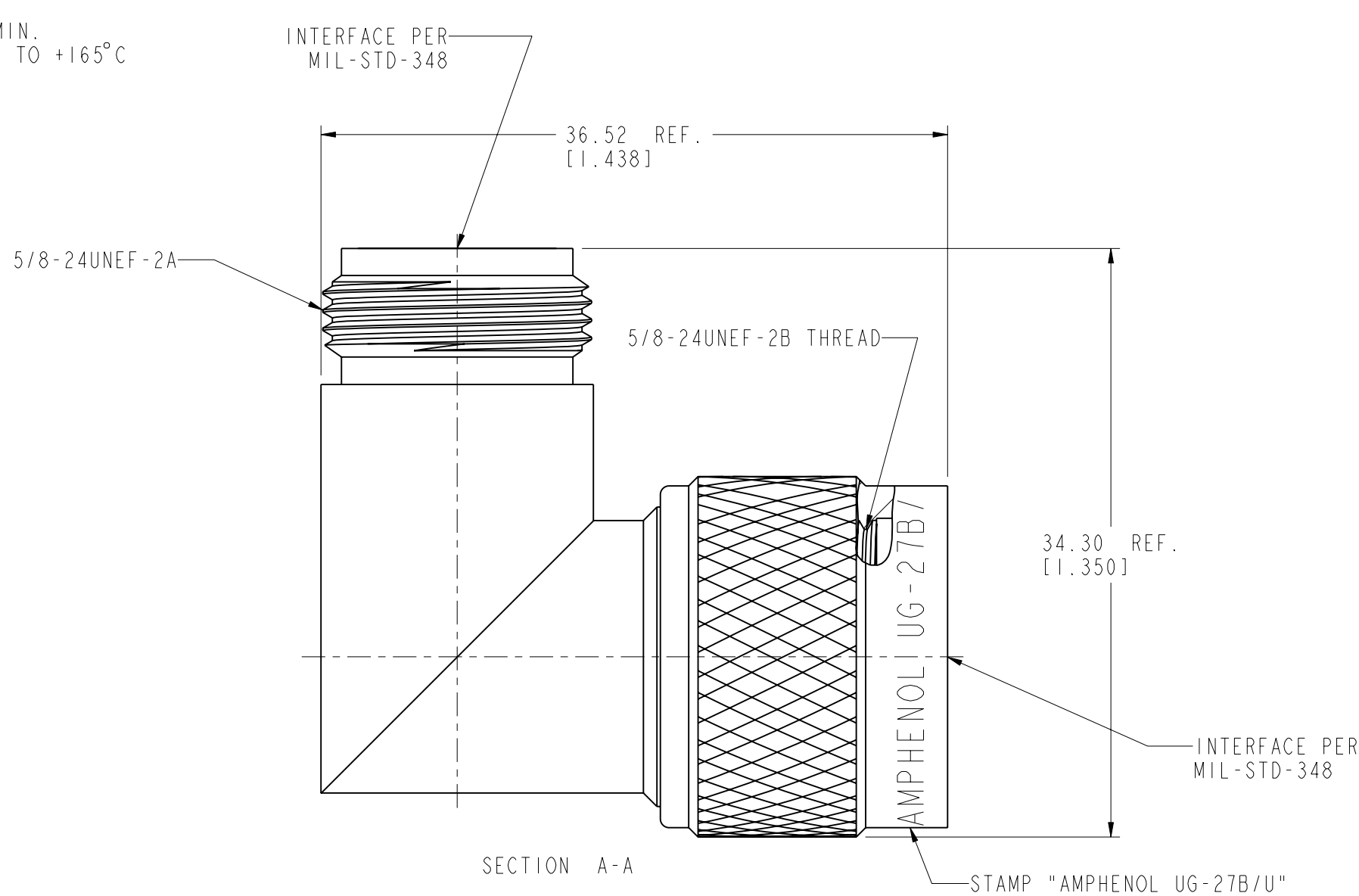

SCALE 2.000

CUSTOMER OUTLINE DRAWING
 ALL OTHER SHEETS ARE FOR INTERNAL USE ONLY

UNLESS OTHERWISE SPECIFIED, DIMENSIONS ARE IN METRIC AND TOLERANCES ARE: <0.5mm ±0.05mm 0.5 - 6mm ±0.1mm 6 - 30mm ±0.2mm 30 - 120mm ±0.3mm ANGLES ±1°	MATERIAL	DRAWN R. MAO	DATE 01-Aug-12	TITLE TYPE 'N' ADAPTOR RIGHT ANGLE UG-27B/U	Amphenol RF Danbury CT USA, Tainan, Taiwan, Shenzhen, China www.amphenolrf.com
	REFERENCE	ENGINEER S. P	DATE 07-Mar-66		
	FINISH	APPROVED S. HSIEH	DATE 01-Aug-12	ITEM NO. 82-98	
		CAD FILE		PART NO. 82-98	