



Chipsmall Limited consists of a professional team with an average of over 10 year of expertise in the distribution of electronic components. Based in Hongkong, we have already established firm and mutual-benefit business relationships with customers from,Europe,America and south Asia,supplying obsolete and hard-to-find components to meet their specific needs.

With the principle of “Quality Parts,Customers Priority,Honest Operation,and Considerate Service”,our business mainly focus on the distribution of electronic components. Line cards we deal with include Microchip,ALPS,ROHM,Xilinx,Pulse,ON,Everlight and Freescale. Main products comprise IC,Modules,Potentiometer,IC Socket,Relay,Connector.Our parts cover such applications as commercial,industrial, and automotives areas.

We are looking forward to setting up business relationship with you and hope to provide you with the best service and solution. Let us make a better world for our industry!



Contact us

Tel: +86-755-8981 8866 Fax: +86-755-8427 6832

Email & Skype: info@chipsmall.com Web: www.chipsmall.com

Address: A1208, Overseas Decoration Building, #122 Zhenhua RD., Futian, Shenzhen, China



MATERIAL NO.	ENGINEERING NO.	SIZE	A REF.	B ± .010
834219014	83421-9014	9	19.93 (.785)	14.35 (.565)
834229014	83422-9014	15	23.75(.935)	18.16 (.715)
834249014	83424-9014	25	30.10 (1.185)	24.51 (.965)

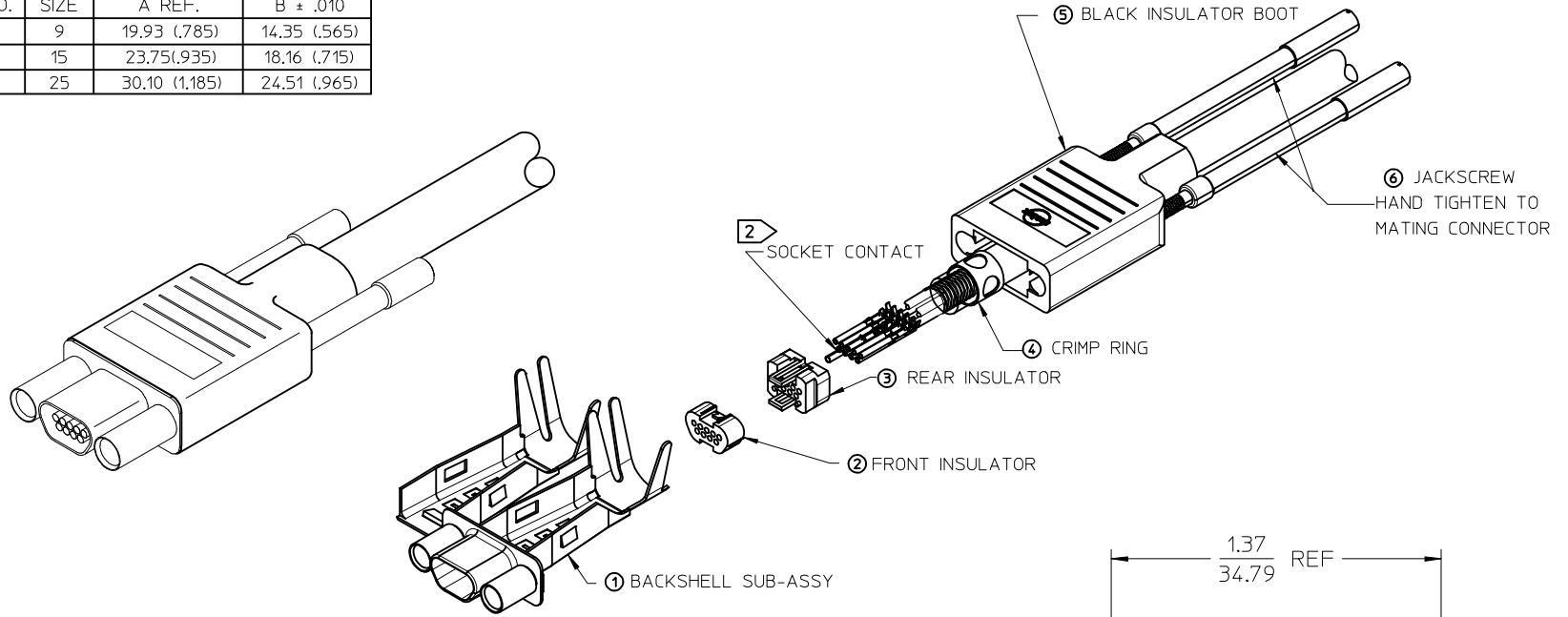

ITEM	ITEM	DESCRIPTION
7	1	ASSEMBLY INSTRUCTIONS NOT SHOWN
6	2	2-56 JACKSCREW UNDIPPED
5	1	RUBBER BOOT MICRO-D
4	1	CRIMP RING MICRO-D
3	1	REAR INSULATOR
2	1	FRONT INSULATOR
1	1	BACKSHELL SUB-ASSY, MICRO-D SIZE I5

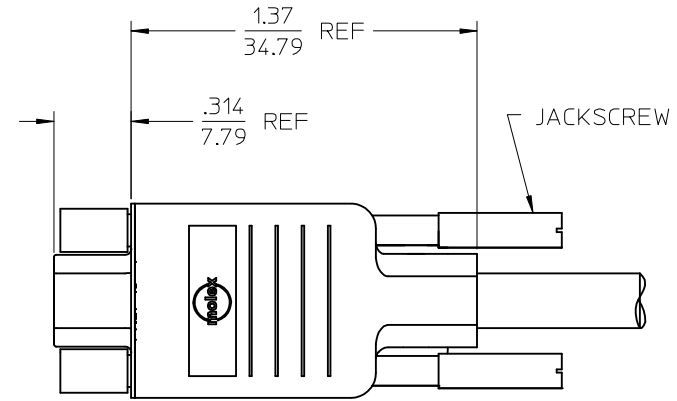
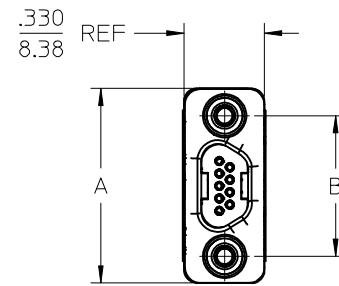

3. ROHS COMPLIANT

CONTACTS SOLD SEPARATELY. ORDER BY:
 P/N 830009502 (2500 CONTACT REEL)
 P/N 830009503 (50000 CONTACT REEL)
 P/N 830000083 (LOOSE CONTACTS)

1. REFER TO PS-83421-001 FOR PRODUCT SPECIFICATION

NOTES: UNLESS OTHERWISE SPECIFIED

ADDED LAYOUT VIEW EC NO: IPG2014-0111 DR: WILBARDEN CHKD: BWOODMAN APPR: BWOODMAN 2013/07/16 2013/07/25	QUALITY SYMBOLS	GENERAL TOLERANCES (UNLESS SPECIFIED)	DIMENSION STYLE	SCALE	DESIGN UNITS	THIRD ANGLE PROJECTION
	▽=0 ▽=0	mm INCH 4 PLACES ± --- ± --- 3 PLACES ± --- ± --- 2 PLACES ± --- ± --- 1 PLACE ± --- ± --- 0 PLACE ± --- ± ---	IN/MM	2:1	INCH	
		ANGULAR ±1/2° DRAFT WHERE APPLICABLE MUST REMAIN WITHIN DIMENSIONS	DRAWN BY DATE URBACH 99/09/03 CHECKED BY DATE HEB 02/01/31 APPROVED BY DATE RWD 02/01/31	TITLE	CONNECTOR KIT, RECEPTACLE, W/2-56 JACKSCREWS molex	
			SEE CHART	MATERIAL NO.	DOCUMENT NO.	SHEET NO.

THIS DRAWING CONTAINS INFORMATION THAT IS PROPRIETARY TO MOLEX INCORPORATED AND SHOULD NOT BE USED WITHOUT WRITTEN PERMISSION

10	9	8	7	6	5	4	3	2	1
MATERIAL NUMBER	ENGINEERING NUMBER								
834219101	83421-9101								

CONNECTOR ASSEMBLY INSTRUCTIONS

- 1 SLIDE INSULATOR BOOT OVER CABLE.
- 2 SLIDE CRIMP RING OVER CABLE.
BRAIDED SHIELD FOLDS BACK OVER CRIMP RING.
- 3 STRIP CABLE PER STRIPPING INSTRUCTIONS. (SH 1&2)

- 4 CRIMP CONTACTS PER CRIMP INSTRUCTIONS. (SH2)
SEE 638522000 & 638622000 FOR APPLICATOR, TERMINATOR DIE AND CRIMP SPEC..
SEE 638114800 FOR HAND TOOL AND CRIMP SPEC.

- 5 INSERT CONTACTS INTO BACK OF REAR INSULATOR USING NEEDLE NOSE PLIERS WITH A 3/64in/1MM TIP
(SPECIAL CARE MUST BE TAKEN NOT TO DAMAGE LOCKING WINGS).
PUSH CONTACT INTO REAR INSULATOR UNTIL "WINGS" ON CONTACT SNAP OPEN.
CONTACT SHOULD NOT EXTEND BEYOND THE BACK OF INSULATOR.
PLACE FRONT INSULATOR ONTO REAR INSULATOR ASSURING PROPER ALIGNMENT OF CONTACTS.
CONTINUE TO PUSH UNTIL FRONT AND REAR INSULATOR SNAP TOGETHER.
LIGHTLY PULL CRIMPED WIRE TO ENSURE TERMINAL HAS LOCKED INTO INSULATOR.
-WARNING PULLING TO HARD CAN DAMAGE CONTACT-

- 6 APPLY ADHESIVE LOCITE 416 OR EQUIVARIANT AROUND EACH WIRE AS SHOWN,
WHERE WIRE ENTERS INSULATOR

- 7 MOUNT INSULATOR SUBASSEMBLY IN BACKSHELL SUBASSEMBLY
PER ASSY INSTRUCTION. (SH2)

- 8 CLOSE BACKSHELL SUBASSEMBLY AROUND CABLE SHIELD PER
INSTRUCTIONS. (SH 2)

- 9 CRIMP BACKSHELL TO METAL BRAID PER INSTRUCTIONS. (SH 2)
SEE CRIMP SPEC.

	9 POSITION	15 POSITION	25 POSITION
MOLEX PRESS	622008900	622019800	622020000
CRIMP KIT	622009000	622019900	622020100

- 10 SLIDE BOOT OVER BACKSHELL SUBASSEMBLY.

- 11 INSERT JACKSCREWS INTO BOOT.

- 12 USE WITH MOLEX TERMINALS 830009502, 830009503 OR 830000083

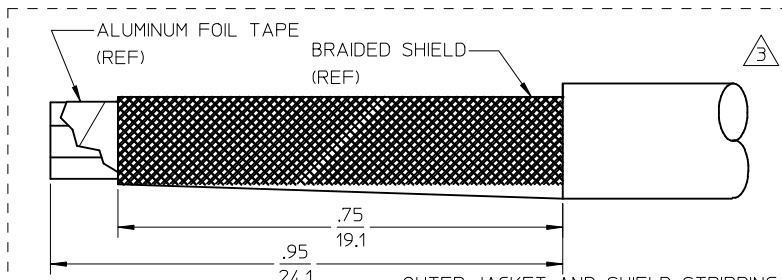
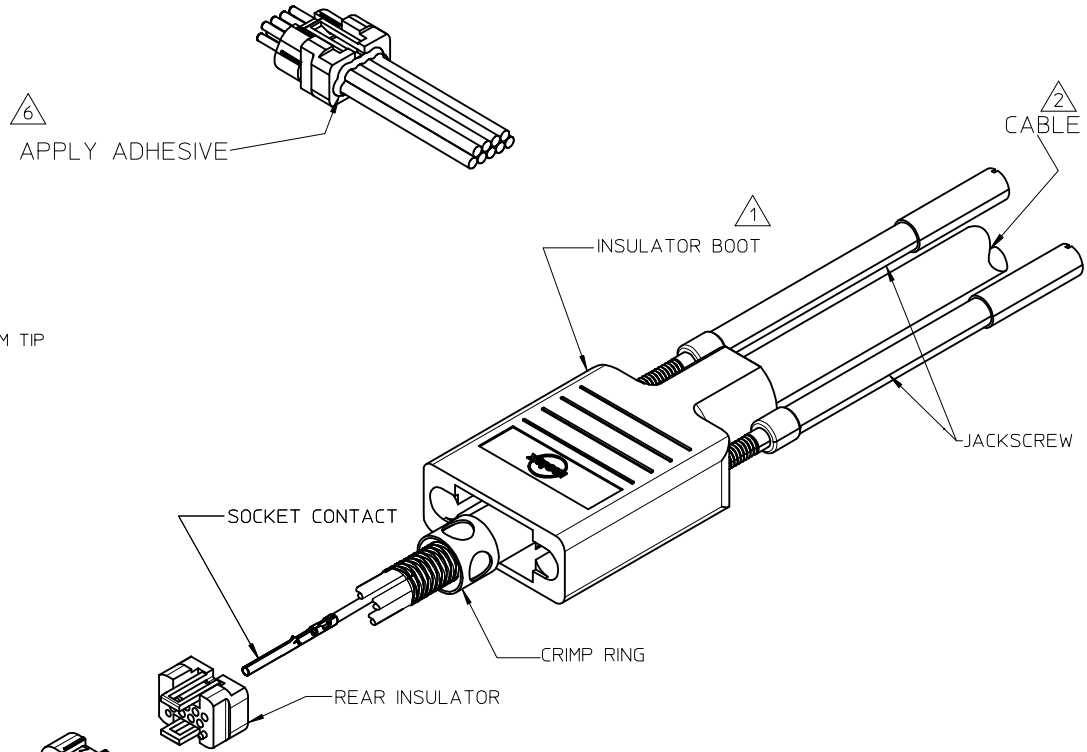
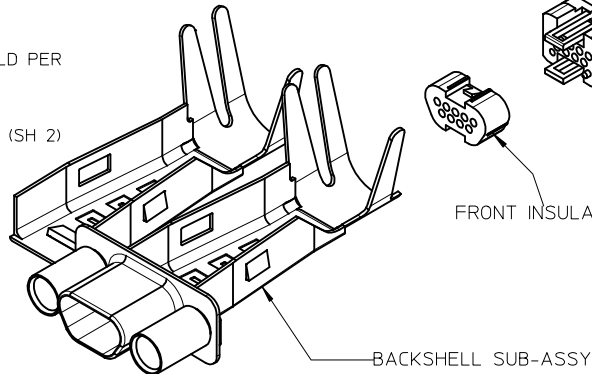

9 POSITION SHOWN

ADDED VIEW & NOTE EC NO: IPG2014-1862 DRWN:GGUSTAFSON 2014/04/25 CHKD: APPR:BWODMAN 2014/05/09	QUALITY SYMBOLS	DESCRIPTION
	▽=0	
	◻=0	
	REV	

GENERAL TOLERANCES (UNLESS SPECIFIED)	mm	INCH	
	4 PLACES	± .---	± .---
	3 PLACES	± .---	± .---
	2 PLACES	± .---	± .---
	1 PLACE	± .---	± .---
ANGULAR ± .---°			
DRAFT WHERE APPLICABLE MUST REMAIN WITHIN DIMENSIONS			

DIMENSION STYLE IN/MM	
DRAWN BY GGUSTAFSON	DATE 2014/03/26
CHECKED BY	DATE
APPROVED BY BWODMAN	DATE 2014/04/04
MATERIAL NO. SEE CHART	
SIZE A3	THIS DRAWING CONTAINS INFORMATION THAT IS PROPRIETARY TO MOLEX INCORPORATED AND SHOULD NOT BE USED WITHOUT WRITTEN PERMISSION

SCALE 2:1	DESIGN UNITS INCH	THIRD ANGLE PROJECTION
ASSEMBLY INSTRUCTIONS COMMERCIAL MICRO D CONNECTOR		
MOLEX INCORPORATED		SHEET NO. 1 OF 2
DOCUMENT NO. SD-83421-040		

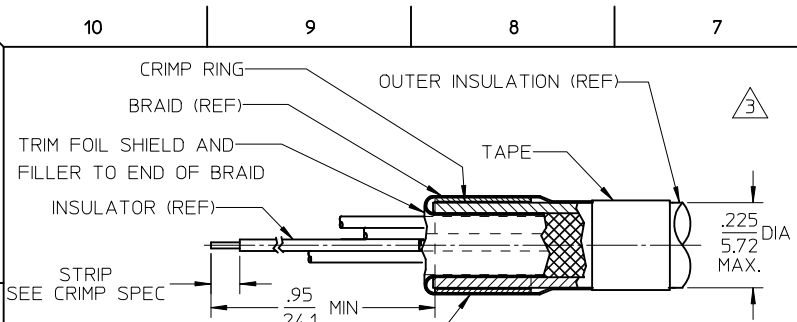

FOLD BRAID BACK OVER CRIMP RING AND COMB EVENLY 360° AROUND RING, PLACE ADHESIVE TAPE AROUND BRAID AS SHOWN
CONDUCTOR STRIPPING (SINGLE INSULATED WIRE)

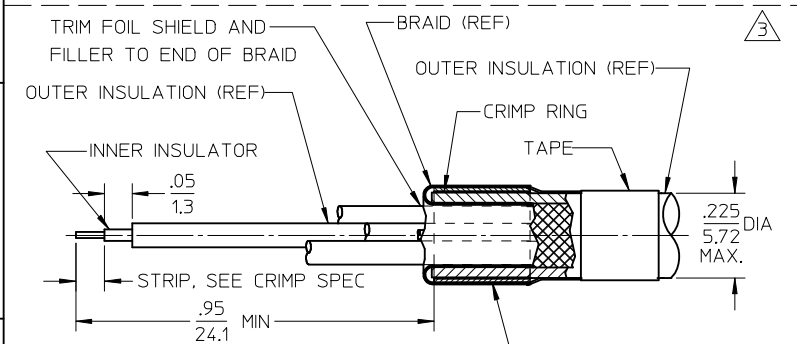

FOLD BRAID BACK OVER CRIMP RING AND COMB EVENLY 360° AROUND RING, PLACE ADHESIVE TAPE AROUND BRAID AS SHOWN.
CONDUCTOR STRIPPING DOUBLE INSULATED WIRE

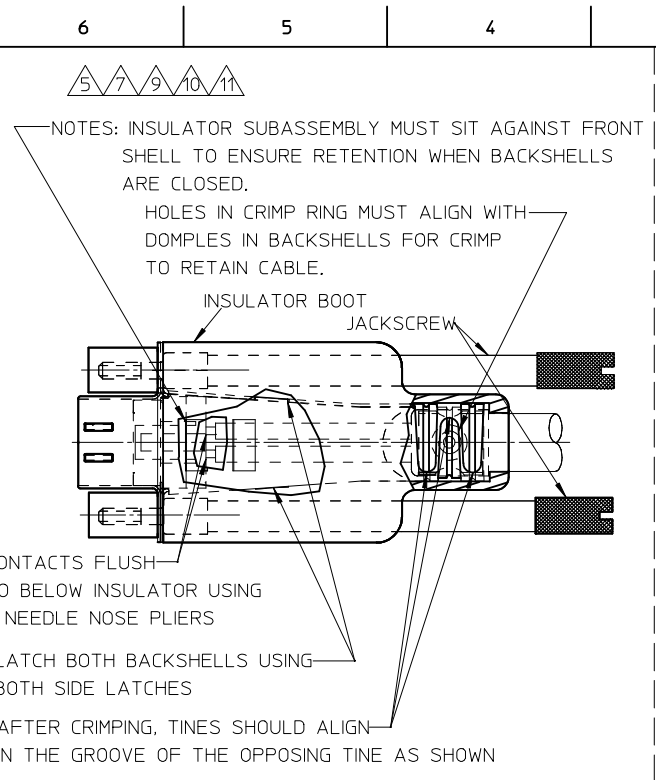
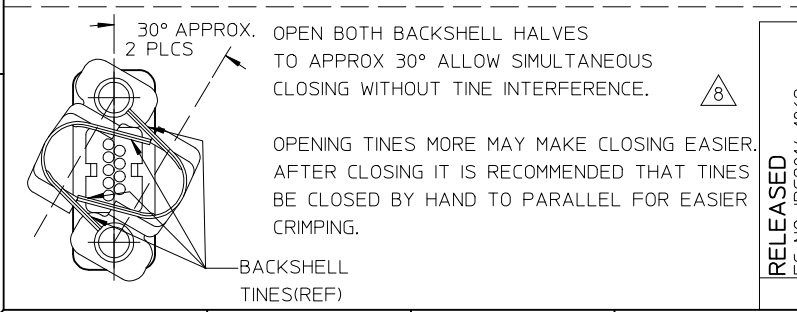
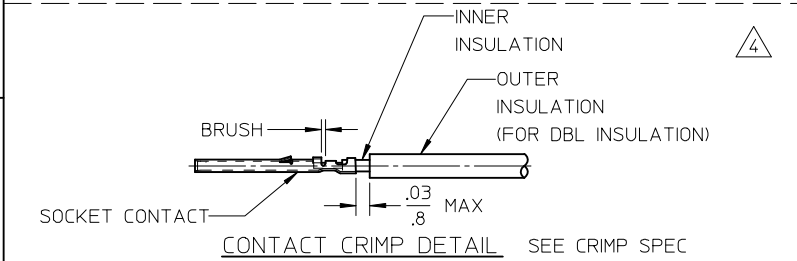

SIZE	DIM A (inch/mm)
9	.320/8.13
15	.370/9.40
25	.420/10.67

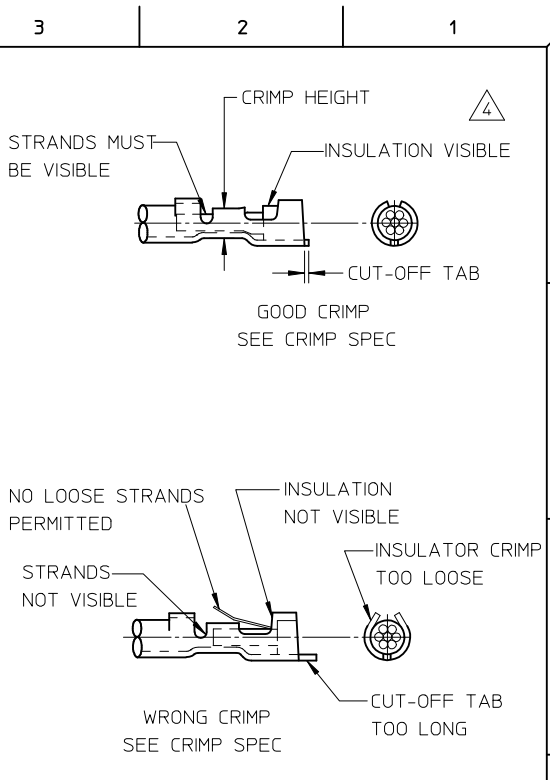
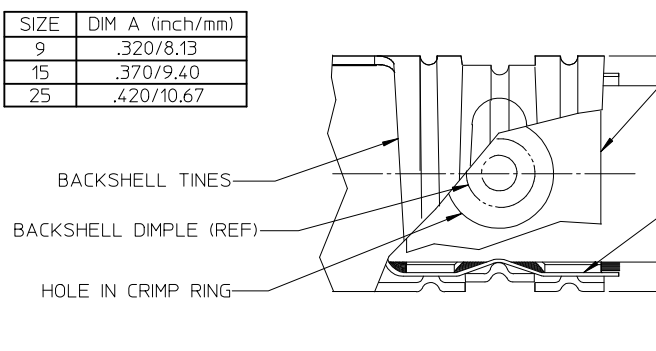

RELEASED EC NO: IPG2014-1862 DRWN:GGUSTAFSON 2014/04/25 CHKD: APPR:BWODMAN 2014/05/09 DESCRIPTION	QUALITY SYMBOLS ▽=0 ▽=0	GENERAL TOLERANCES (UNLESS SPECIFIED) <table border="1"> <thead> <tr> <th></th> <th>mm</th> <th>INCH</th> </tr> </thead> <tbody> <tr> <td>4 PLACES</td> <td>± ---</td> <td>± ---</td> </tr> <tr> <td>3 PLACES</td> <td>± ---</td> <td>± ---</td> </tr> <tr> <td>2 PLACES</td> <td>± ---</td> <td>± ---</td> </tr> <tr> <td>1 PLACE</td> <td>± ---</td> <td>± ---</td> </tr> </tbody> </table>		mm	INCH	4 PLACES	± ---	± ---	3 PLACES	± ---	± ---	2 PLACES	± ---	± ---	1 PLACE	± ---	± ---	DIMENSION STYLE IN/MM DRAWN BY: GGUSTAFSON DATE: 2014/03/26 CHECKED BY: _____ DATE: _____	SCALE: 2:1 DESIGN UNITS: INCH THIRD ANGLE PROJECTION	TITLE: ASSEMBLY INSTRUCTIONS COMMERCIAL MICRO D CONNECTOR
		mm	INCH																	
4 PLACES	± ---	± ---																		
3 PLACES	± ---	± ---																		
2 PLACES	± ---	± ---																		
1 PLACE	± ---	± ---																		
DRAFT WHERE APPLICABLE MUST REMAIN WITHIN DIMENSIONS SEE CHART	APPROVED BY: BWODMAN DATE: 2014/04/04 MATERIAL NO.	MOLEX INCORPORATED DOCUMENT NO. SD-83421-040	SHEET NO. 2 OF 2																	