



Chipsmall Limited consists of a professional team with an average of over 10 year of expertise in the distribution of electronic components. Based in Hongkong, we have already established firm and mutual-benefit business relationships with customers from,Europe,America and south Asia,supplying obsolete and hard-to-find components to meet their specific needs.

With the principle of “Quality Parts,Customers Priority,Honest Operation,and Considerate Service”,our business mainly focus on the distribution of electronic components. Line cards we deal with include Microchip,ALPS,ROHM,Xilinx,Pulse,ON,Everlight and Freescale. Main products comprise IC,Modules,Potentiometer,IC Socket,Relay,Connector.Our parts cover such applications as commercial,industrial, and automotives areas.

We are looking forward to setting up business relationship with you and hope to provide you with the best service and solution. Let us make a better world for our industry!



## Contact us

Tel: +86-755-8981 8866 Fax: +86-755-8427 6832

Email & Skype: info@chipsmall.com Web: www.chipsmall.com

Address: A1208, Overseas Decoration Building, #122 Zhenhua RD., Futian, Shenzhen, China





# XRC™ CONNECTOR ASSEMBLY INSTRUCTIONS

## PLUG AND RECEPTACLE ASSEMBLY

### TERMINAL INSERTION

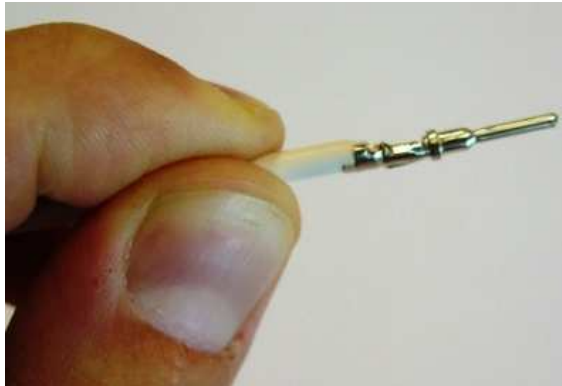

1

Grasp the terminal approximately 1 inch (25.4mm) behind insulation crimp.



2

Hold the connector with the wire seal grommet facing the terminal.

**Note:** For unused wire cavities, insert sealing plugs for full environmental sealing.



3

Push the terminal straight into the connector until a positive stop is felt. A slight tug will confirm that it is properly locked into place.

LOCKING MECHANISM

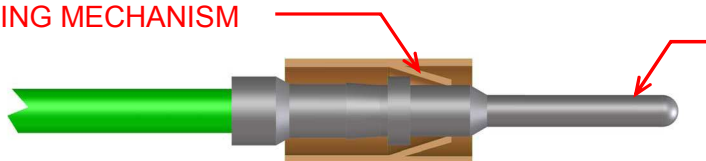

TERMINAL

TERMINAL BEING PUSHED INTO THE LOCKING MECHANISM

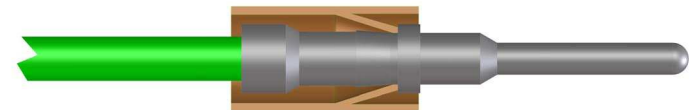

TERMINAL LOCKED INTO POSITION

<u>REVISION:</u>  <b>A</b>	<u>ECR/ECN INFORMATION:</u> <u>EC No:</u> WNA2010-0052 <u>DATE:</u> 2009 / 07 / 22	<u>TITLE:</u> <b>ASSEMBLY INSTRUCTIONS  FOR XRC™ (EXTRA RUGGED CIRCULAR)  SEALED CONNECTORS</b>	<u>SHEET No.</u>  <b>1 of 4</b>	
<u>DOCUMENT NUMBER:</u> <b>AS-84501-001</b>		<u>CREATED / REVISED BY:</u> <b>W. LEUNG</b>	<u>CHECKED BY:</u> <b>T. MOELLER</b>	<u>APPROVED BY:</u> <b>D. TITUS</b>



# XRC™ CONNECTOR ASSEMBLY INSTRUCTIONS

## PLUG AND RECEPTACLE ASSEMBLY

### TERMINAL EXTRACTION

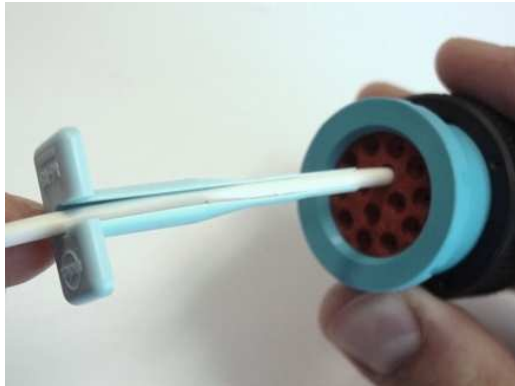

1

Hold the connector with the wire seal grommet facing the appropriate size extractor tool. Snap the tool onto the terminal wire.

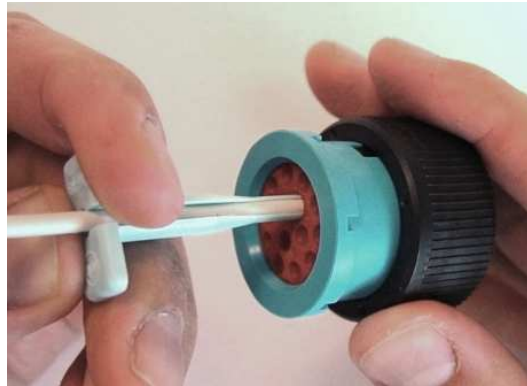

2

Slide tool along the wire into the insert cavity until it engages the terminal and resistance is felt.

**Note:** Do not twist or insert tool at an angle.

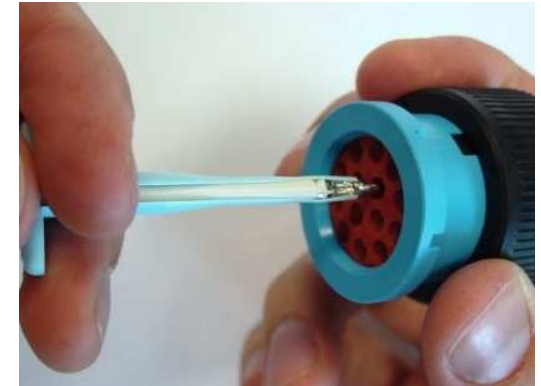

3

Pull the terminal wire lead along with the tool out of the connector.

EXTRACTION TOOL

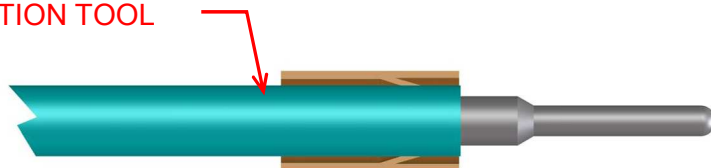

**EXTRACTION TOOL INSERTED  
TO UNLOCK TERMINAL**

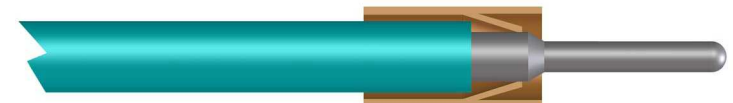

**TOOL AND TERMINAL BEING REMOVED**

<u>REVISION:</u>  <b>A</b>	<u>ECR/ECN INFORMATION:</u> <u>EC No:</u> WNA2010-0052 <u>DATE:</u> 2009 / 07 / 22	<u>TITLE:</u> <b>ASSEMBLY INSTRUCTIONS  FOR XRC™ (EXTRA RUGGED CIRCULAR)  SEALED CONNECTORS</b>	<u>SHEET No.</u>  <b>2 of 4</b>
<u>DOCUMENT NUMBER:</u>  <b>AS-84501-001</b>	<u>CREATED / REVISED BY:</u>  <b>W. LEUNG</b>	<u>CHECKED BY:</u>  <b>T. MOELLER</b>	<u>APPROVED BY:</u>  <b>D. TITUS</b>



# XRC™ CONNECTOR ASSEMBLY INSTRUCTIONS

## MATING/UNMATING PROCEDURE FOR XRC™ 18-14 CONNECTOR

### A. TO MATE THE PLUG TO THE RECEPTACLE –

1. LINE UP THE BLACK VISUAL ALIGNMENT SQUARE ON THE PLUG WITH EITHER THE FLAT SURFACE OR THE BLACK VISUAL ALIGNMENT SQUARE ON THE RECEPTACLE.
2. TURN THE COUPLING RING ¼ TURN CLOCKWISE UNTIL A POSITIVE STOP IS FELT.

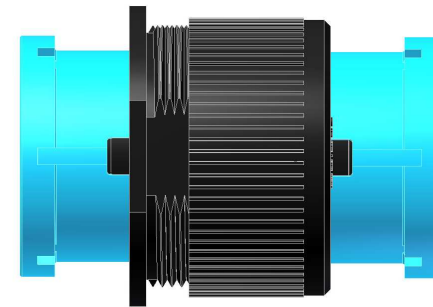
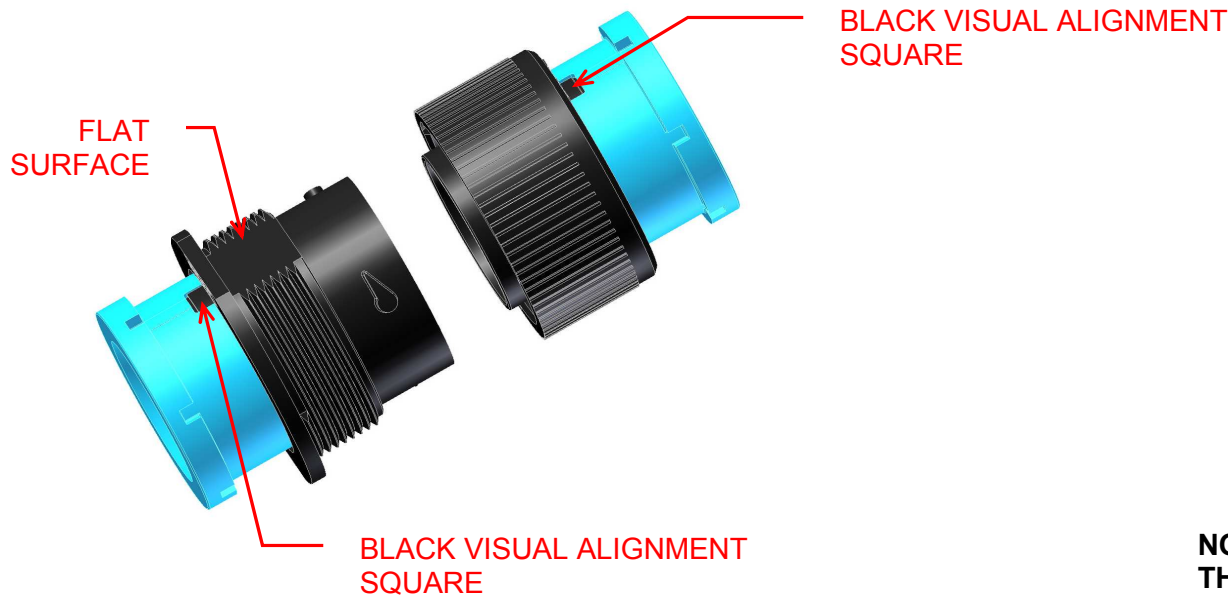

**NOTE:**  
THERE WILL BE A TACTILE AND AUDIBLE  
FEEDBACK WHEN MATED CORRECTLY.

### B. TO UNMATE THE PLUG FROM THE RECEPTACLE, REVERSE THE ABOVE PROCEDURE.

<u>REVISION:</u> <b>A</b>	<u>ECR/ECN INFORMATION:</u> EC No: <b>WNA2010-0052</b> DATE: <b>2009 / 07 / 22</b>	<u>TITLE:</u> <b>ASSEMBLY INSTRUCTIONS FOR XRC™ (EXTRA RUGGED CIRCULAR) SEALED CONNECTORS</b>	<u>SHEET No.</u> <b>3 of 4</b>
<u>DOCUMENT NUMBER:</u> <b>AS-84501-001</b>	<u>CREATED / REVISED BY:</u> <b>W. LEUNG</b>	<u>CHECKED BY:</u> <b>T. MOELLER</b>	<u>APPROVED BY:</u> <b>D. TITUS</b>



# XRC™ CONNECTOR ASSEMBLY INSTRUCTIONS

## MATING/UNMATING PROCEDURE FOR XRC™ 24-31 CONNECTOR

### A. TO MATE THE PLUG TO THE RECEPTACLE –

1. LINE UP THE VISUAL ALIGNMENT RAISED TAB ON THE PLUG WITH EITHER THE FLAT SURFACE OR THE VISUAL ALIGNMENT RAISED TAB ON THE RECEPTACLE.
2. TURN THE COUPLING RING ¼ TURN CLOCKWISE UNTIL A POSITIVE STOP IS FELT.

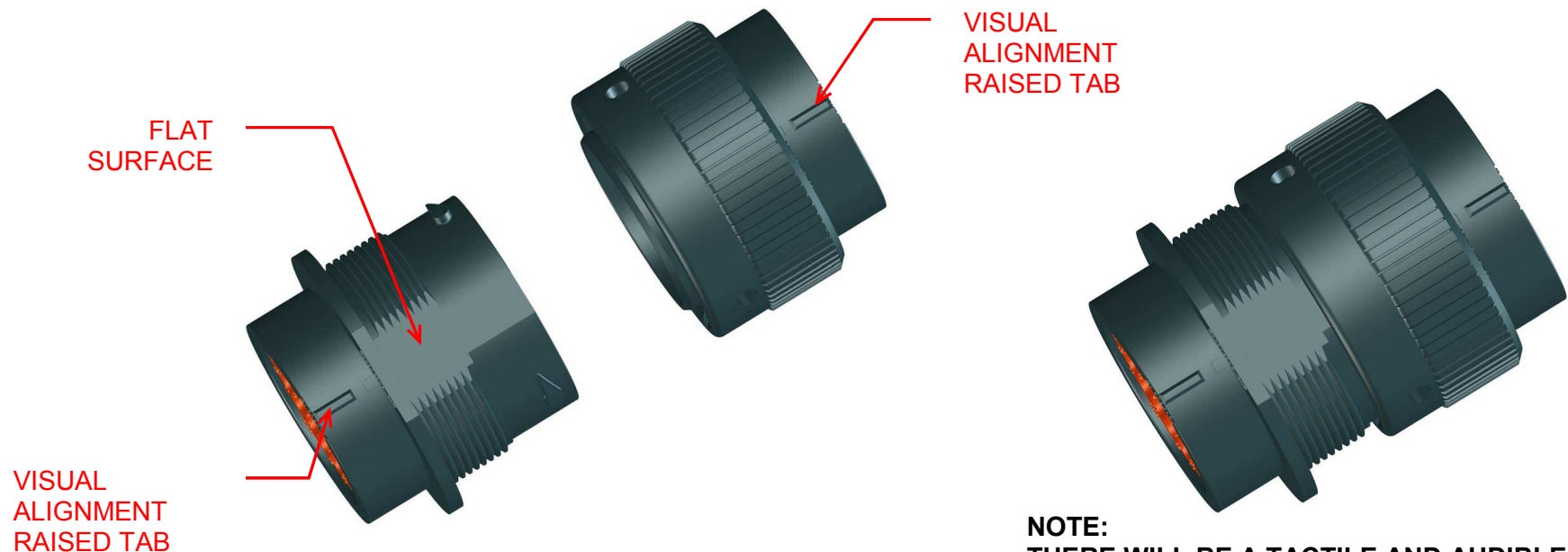

**NOTE:**  
THERE WILL BE A TACTILE AND AUDIBLE FEEDBACK WHEN MATED CORRECTLY.

### B. TO UNMATE THE PLUG FROM RECEPTACLE, REVERSE THE ABOVE PROCEDURE.

REVISION: <b>A</b>	ECR/ECN INFORMATION: EC No: <b>WNA2010-0052</b> DATE: <b>2009 / 07 / 22</b>	TITLE: <b>ASSEMBLY INSTRUCTIONS FOR XRC™ (EXTRA RUGGED CIRCULAR) SEALED CONNECTORS</b>	SHEET No. <b>4 of 4</b>
DOCUMENT NUMBER: <b>AS-84501-001</b>	CREATED / REVISED BY: <b>W. LEUNG</b>	CHECKED BY: <b>T. MOELLER</b>	APPROVED BY: <b>D. TITUS</b>