



Chipsmall Limited consists of a professional team with an average of over 10 year of expertise in the distribution of electronic components. Based in Hongkong, we have already established firm and mutual-benefit business relationships with customers from,Europe,America and south Asia,supplying obsolete and hard-to-find components to meet their specific needs.

With the principle of "Quality Parts,Customers Priority,Honest Operation,and Considerate Service",our business mainly focus on the distribution of electronic components. Line cards we deal with include Microchip,ALPS,ROHM,Xilinx,Pulse,ON,Everlight and Freescale. Main products comprise IC,Modules,Potentiometer,IC Socket,Relay,Connector.Our parts cover such applications as commercial,industrial, and automotives areas.

We are looking forward to setting up business relationship with you and hope to provide you with the best service and solution. Let us make a better world for our industry!



Contact us

Tel: +86-755-8981 8866 Fax: +86-755-8427 6832

Email & Skype: info@chipsmall.com Web: www.chipsmall.com

Address: A1208, Overseas Decoration Building, #122 Zhenhua RD., Futian, Shenzhen, China



GIGABIT SINGLE PORT MAGNETIC JACK
PoE+ MAGNETICS ACC. TO IEEE802.3at
FOR PSE OR PD APPLICATIONS

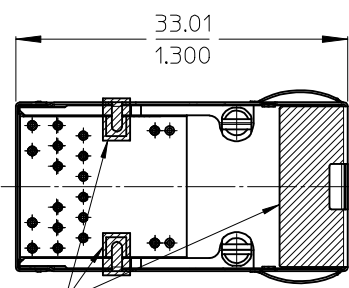
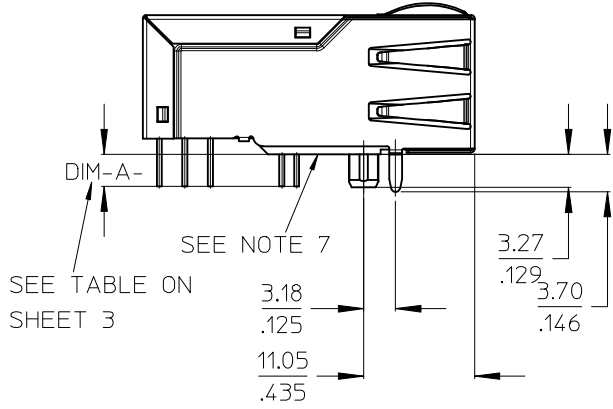
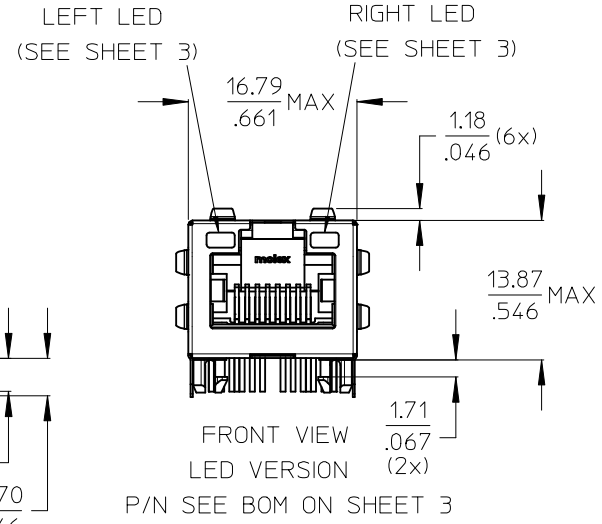
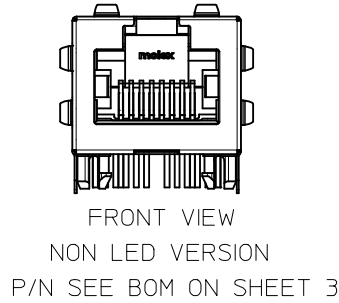
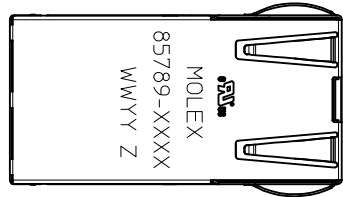

- NOTES:
- SHIELD MATERIAL: STAINLESS STEEL
(GROUND PINS ARE SOLDER DIPPED)
 - PLASTIC MATERIAL: PBT, BLACK, UL 94V-0
 - TERMINALS MATERIAL: PHOSPOR BRONZE
RJ45 CONTACTS PLATING: 0.76 MICROMETER GOLD
OVER 1.9 MICROMETER NICKEL ON MATING AREA
SOLDER TERMINALS: 3 MICROMETER TIN
 - MATING INTERFACE ACCORDING TO IEC 60603-7
 - PRODUCT SPECIFICATION: PS-85789-001
 - PACKAGING SPECIFICATION: PK-85759-001
 - STAND OFF TO SYSTEM BOARD
 - RECOMMENDED PCB THICKNESS: 1.6mm / 0.067inch
 - SHIELD AND SHIELD LATCHES: AVOID TO ROUTE TRACES OR TO PLACE ANY VIAS OR PADS IN THIS AREA.
 - INSCRIPTION MARKED BY LASER:
UL LOGO
1st : MOLEX
2st : P/N (SEE BOM)
3rd : DATE CODE(WEEK/YEAR)
Z=> MANUFACTURER CODE

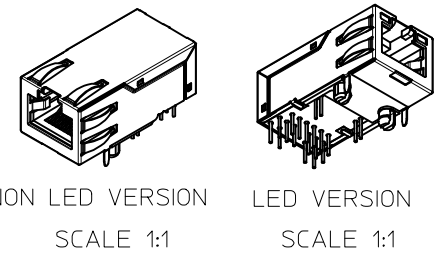

NOTES UPDATE IEC NO: DRWN:MMANGARUDOV 2014/11/28 CH'KD:DBYRNES 2014/12/05 APPR:SSSTE INKE 2014/12/22	QUALITY SYMBOLS ▽=0 ◻=0	GENERAL TOLERANCES (UNLESS SPECIFIED)		DIMENSION STYLE MM/IN		SCALE 2:1	DESIGN UNITS METRIC	THIRD ANGLE PROJECTION	
		4 PLACES ± --- ± ---	mm INCH	DRAWN BY JBADER	DATE 2014/04/25	TITLE GIGABIT MAGNETIC JACK POE PLUS ENABLED 1X1			
		3 PLACES ± --- ± .010		CHECKED BY MMANGARUDOV	DATE 2014/05/05	molex			
		2 PLACES ± 0.25 ± .020		APPROVED BY SSTE INKE	DATE 2014/06/11				
1 PLACE ± 0.5 ± ---		MATERIAL NO. SEE SHEET 3		DOCUMENT NO. SD-85789-401	SHEET NO. 1 OF 3				
0 PLACE ± ±	ANGULAR ± .5 °	DRAFT WHERE APPLICABLE MUST REMAIN WITHIN DIMENSIONS							

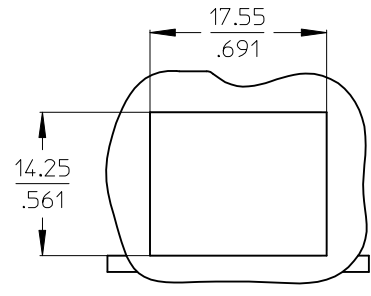
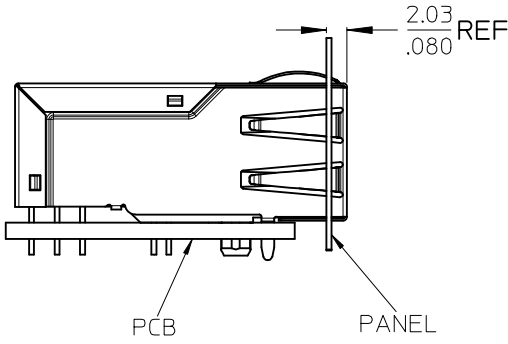

SUGGESTED PANEL CUTOUT

SUGGESTED BOARD LAYOUT - COMPONENT SIDE

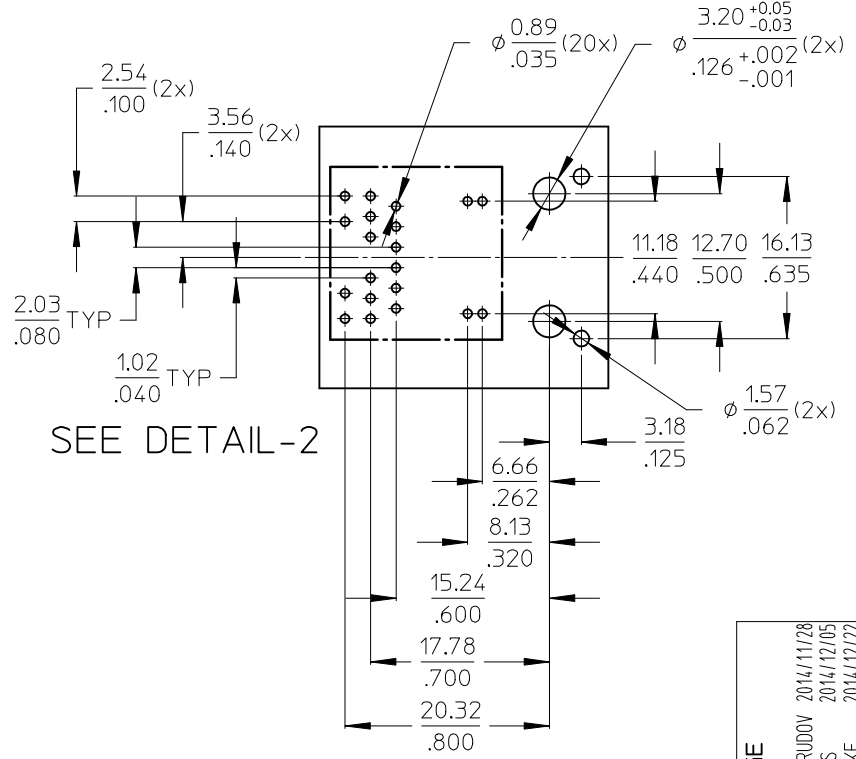

SEE DETAIL-2

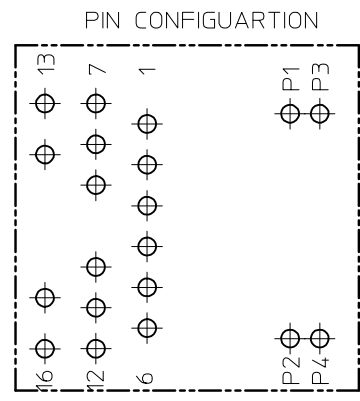

DETAIL-2
SCALE 4:1

SUGGESTED BOARD LAYOUT
NON LED VERSION

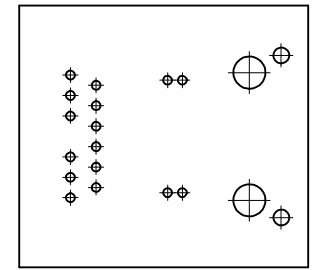

NO CHANGE EC NO: DRW:MMANGARUDOV 2014/11/28 CHK:DJBRYNES 2014/12/05 APPR:SSSTEINKE 2014/12/22	REV DESCRIPTION	QUALITY SYMBOLS	GENERAL TOLERANCES (UNLESS SPECIFIED)	DIMENSION STYLE	SCALE	DESIGN UNITS	THIRD ANGLE PROJECTION	
		$\nabla=0$ $\sphericalangle=0$	mm INCH 4 PLACES ± --- ± --- 3 PLACES ± --- ±.010 2 PLACES ± 0.25 ±.020 1 PLACE ± 0.5 ± --- 0 PLACE ± ±	MM/IN	2:1	METRIC	DRAWN BY: JBADER DATE: 2014/04/25 CHECKED BY: DATE: MMANGARUDOV 2014/05/05 APPROVED BY: DATE: SSTEINKE 2014/06/11	TITLE GIGABIT MAGNETIC JACK POE PLUS ENABLED 1X1 molex DOCUMENT NO. SD-85789-401 SHEET NO. 2 OF 3
		ANGULAR ± .5 ° DRAFT WHERE APPLICABLE MUST REMAIN WITHIN DIMENSIONS	MATERIAL NO. SEE SHEET 3	THIS DRAWING CONTAINS INFORMATION THAT IS PROPRIETARY TO MOLEX INCORPORATED AND SHOULD NOT BE USED WITHOUT WRITTEN PERMISSION				
		SIZE A3						

Electrical Specifications @25°C		
Operating temperature (-40°C to +85°C)		
Description	Value	
OCL POE+TRANSF. 20mA bias (-40°C to +85°C)	350μH min.	
OCL NONPOE TRANSF. 8mA bias (-40°C to +85°C)	350μH min.	
Turns Ratio	1CT:1CT	
Insertion Loss		
Frequency (MHz)	Limits (dB max.)	Typical Values (dB max.)
1.0-9.9 MHz	0.4+0.1*log(F)	0.5 @ 10MHz
10-49.9 MHz	0.5+0.3*log(F/10)	0.7 @ 50MHz
50-79.9 MHz	1+1.4*log(F/80)	1.0 @ 80MHz
80-100 MHz	1.3+3*log(F/100)	1.3 @ 100MHz
Return Loss		
Frequency (MHz)	Limits (dB min.)	TYPICAL Values (dB min.)
1-9.9 MHz	27dB min.	27 @ 10MHz
10-100 MHz	27-17*log(F/10)	10 @ 100MHz
CMR		
Frequency (MHz)	Limits (dB min.)	TYPICAL Values (dB min.)
1-9.9 MHz	34dB min.	34 @ 10MHz
10-79.9 MHz	27dB min.	27 @ 80MHz
80-199.9 MHz	27-14.5*log(F/80)	21.5 @ 200MHz
200-399.9 MHz	21.5-39*log(F/200)	10 @ 400MHz
400-1000 MHz	10	10 @ 1000MHz
NEXT		
Frequency (MHz)	Limits (dB min.)	TYPICAL Values (dB min.)
1-5.9 MHz	50	50 @ 6MHz
6-49.9 MHz	45-16*log(F/10)	34 @ 50MHz
50-100 MHz	25-30*log(F/100)	25 @ 100MHz
Isolation PHY to Wire side	2.25kVDC/60sec	

PHY SIDE / PCB SIDE ETHERNET MAGNETICS WIRE SIDE / RJ45

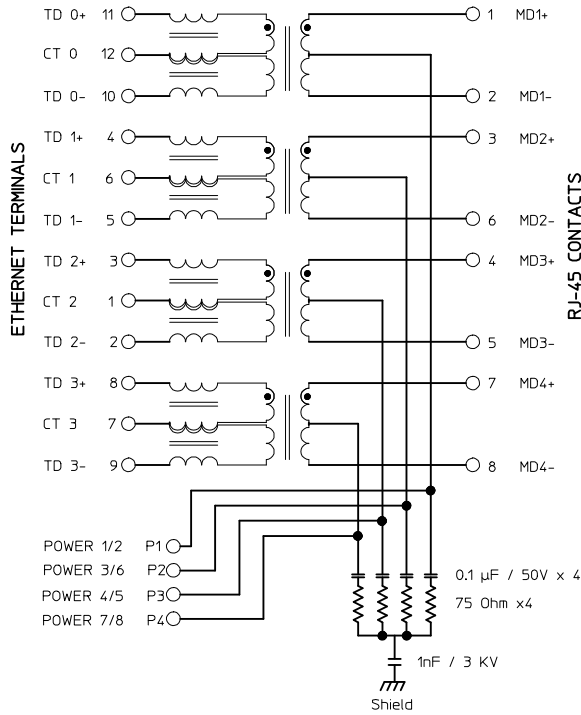

PART NUMBER	DIM-A-SHEET 1	LED1 POLARITY			LED2 POLARITY		
		PIN15	PIN16	COLOR	PIN13	PIN14	COLOR
85789-4008	2.50mm	-	+	GREEN	-	+	GREEN
		+	-	YELLOW	+	-	YELLOW
85789-4020	2.50mm	NON LED					

ADDITIONAL LED COLORS AND CONFIGURATIONS ARE AVAILABLE ON REQUEST

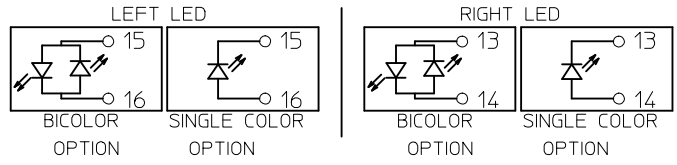

SEE TABLE FOR LED OPTIONS

BOM UPDATE EC NO: DRWIN:MANGARUDOV 2014/11/28 CHYKD:BYRNES 2014/12/05 APPR:SSTEINKE 2014/12/22	QUALITY SYMBOLS	GENERAL TOLERANCES (UNLESS SPECIFIED)	DIMENSION STYLE	SCALE	DESIGN UNITS	THIRD ANGLE PROJECTION																		
	▽=0 ◻=0	<table border="1"> <tr> <th></th> <th>mm</th> <th>INCH</th> </tr> <tr> <td>4 PLACES</td> <td>± ---</td> <td>± ---</td> </tr> <tr> <td>3 PLACES</td> <td>± ---</td> <td>± .010</td> </tr> <tr> <td>2 PLACES</td> <td>± 0.25</td> <td>± .020</td> </tr> <tr> <td>1 PLACE</td> <td>± 0.5</td> <td>± ---</td> </tr> <tr> <td>0 PLACE</td> <td>±</td> <td>±</td> </tr> </table>		mm	INCH	4 PLACES	± ---	± ---	3 PLACES	± ---	± .010	2 PLACES	± 0.25	± .020	1 PLACE	± 0.5	± ---	0 PLACE	±	±	MM/IN	5:1	METRIC	
		mm	INCH																					
	4 PLACES	± ---	± ---																					
	3 PLACES	± ---	± .010																					
2 PLACES	± 0.25	± .020																						
1 PLACE	± 0.5	± ---																						
0 PLACE	±	±																						
	ANGULAR ± .5 °	DRAWN BY	DATE	TITLE																				
	DRAFT WHERE APPLICABLE MUST REMAIN WITHIN DIMENSIONS	JBADER	2014/04/25	GIGABIT MAGNETIC JACK POE PLUS ENABLED 1X1																				
		CHECKED BY	DATE	MATERIAL NO.																				
		MMANGARUDOV	2014/05/05	DOCUMENT NO.																				
		APPROVED BY	DATE	SHEET NO.																				
		SSTEINKE	2014/06/11	SD-85789-401																				
				3 OF 3																				
				THIS DRAWING CONTAINS INFORMATION THAT IS PROPRIETARY TO MOLEX INCORPORATED AND SHOULD NOT BE USED WITHOUT WRITTEN PERMISSION																				

GIGABIT SINGLE PORT MAGNETIC JACK
PoE+ MAGNETICS ACC. TO IEEE802.3at
FOR PSE OR PD APPLICATIONS

- NOTES:**
- 1 - SHIELD MATERIAL: STAINLESS STEEL
(GROUND PINS ARE SOLDER DIPPED)
 - 2 - PLASTIC MATERIAL: PBT, BLACK, UL 94V-0
 - 3 - RJ45 TERMINALS MATERIAL: COPPER ALLOY
CONTACT PLATING: 0.76 MICROMETER GOLD
OVER 1.9 MICROMETER NICKEL
PHY TERMINALS: TIN PLATED
 - 4 - MATING INTERFACE ACCORDING TO IEC 60603-7
 - 5 - PRODUCT SPECIFICATION: PS-85789-001
 - 6 - PACKAGING SPECIFICATION: PK-85759-001
 - 7 - STAND OFF TO SYSTEM BOARD
 - 8 - RECOMMENDED PCB THICKNESS: 1.6mm / 0.067inch
 - 9 - SHIELD AND SHIELD LATCHES: AVOID TO ROUTE TRACES OR TO PLACE ANY VIAS OR PADS IN THIS AREA.
 - 10 - INSCRIPTION MARKED BY LASER:
UL LOGO
1st : MOLEX
2st : P/N (SEE BOM)
3rd : DATE CODE(WEEK/YEAR)
Z=> MANUFACTURER CODE

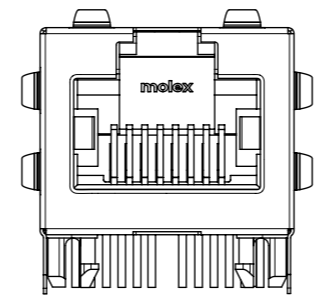
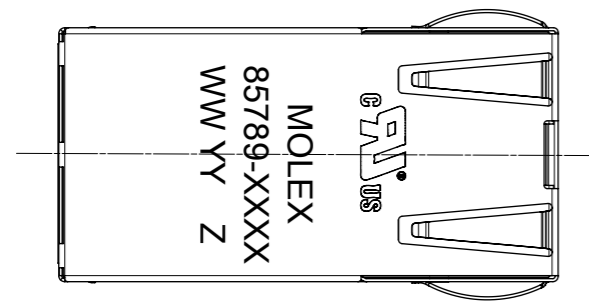

FRONT VIEW
NON LED VERSION
P/N 85789-1020

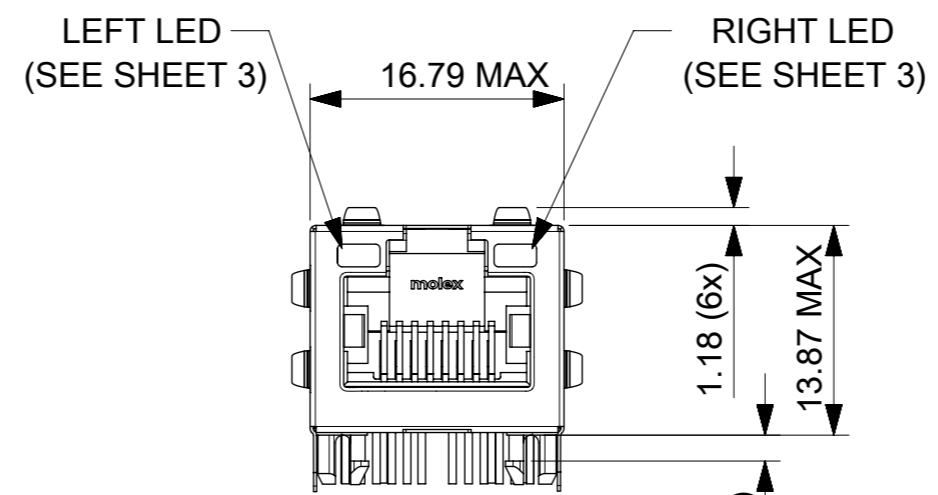
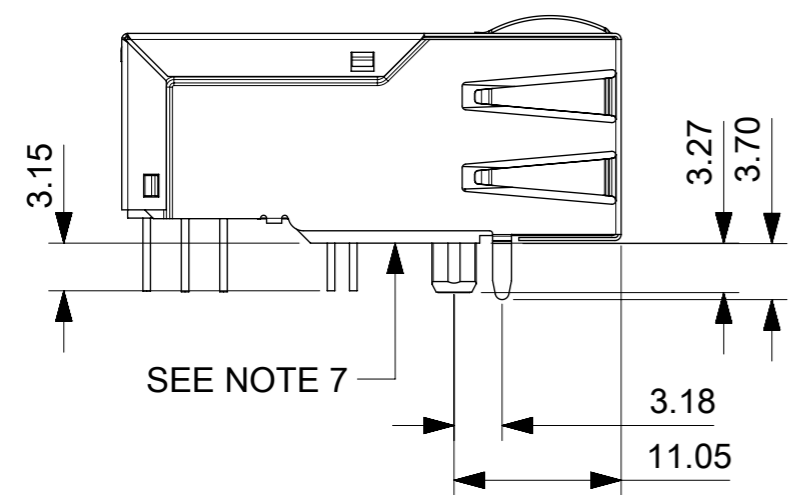

FRONT VIEW
LED VERSION
P/N SEE BOM ON SHEET 3

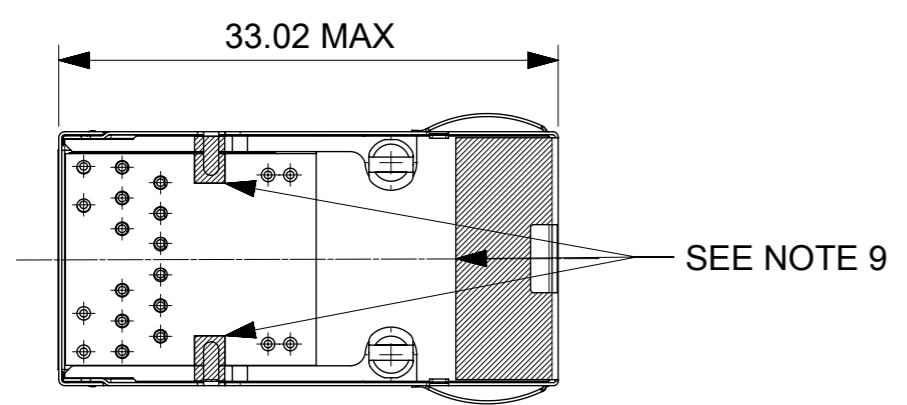
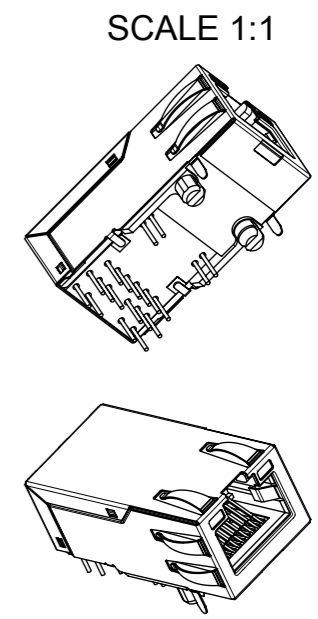

THIS DRAWING CONTAINS INFORMATION THAT IS PROPRIETARY TO MOLEX INCORPORATED AND SHOULD NOT BE USED WITHOUT WRITTEN PERMISSION										
EC DESCRIPTION EC NO: 102890 DRWN: MFURKEL CHK'D: APPR: RSILLER	2015/09/28	QUALITY SYMBOLS ∇ = 0 ∇ = 0 ∇ = 0 ▼ = 0 ∇ = 0 ⊠ = 0 ■ = 0 ∇ = 0	GENERAL TOLERANCES (UNLESS SPECIFIED)		DIMENSION UNITS	SCALE				
				ANGULAR TOL ± 0.5 °		MM				2:1
				4 PLACES ±		DRWN BY	DATE	GIGABIT MAGNETIC JACK POE PLUS ENABLED		
				3 PLACES ±		MFURKEL	2015/06/15			
		2 PLACES ± 0.25		CHK'D BY	DATE	PRODUCT CUSTOMER DRAWING				
		1 PLACE ± 0.5								
		0 PLACES ±		APPR BY	DATE	SERIES	MATERIAL NUMBER	CUSTOMER		
						85789	SEE BOM/SHEET 3/4			
						DOCUMENT NUMBER	DOC TYPE	DOC PART	SHEET NUMBER	
						857891001	PSD	000	1 OF 4	

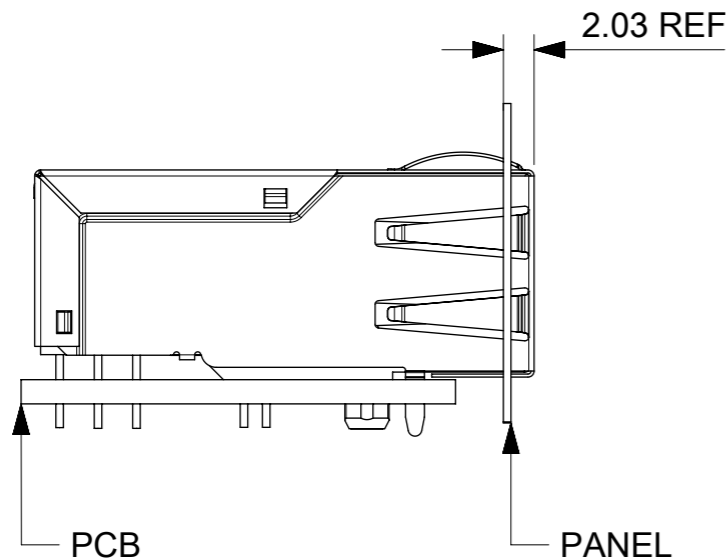

SUGGESTED PANEL CUTOUT

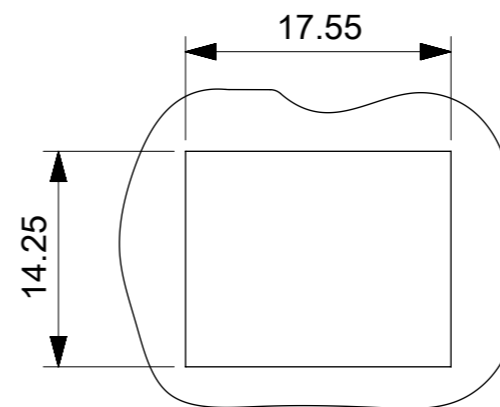

DETAIL X
SCALE 4:1
PIN CONFIGURATION

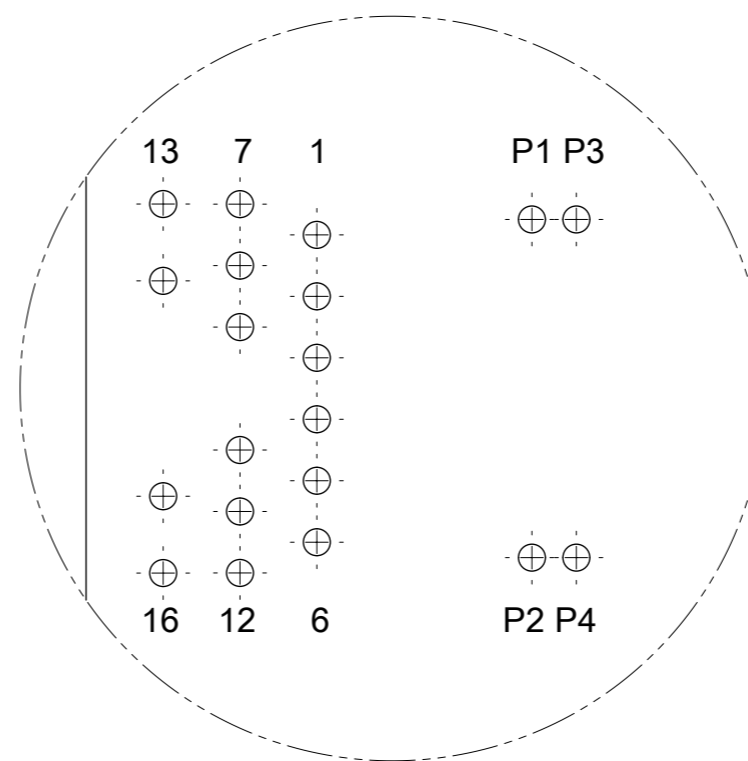

SUGGESTED BOARD LAYOUT- COMPONENT SIDE

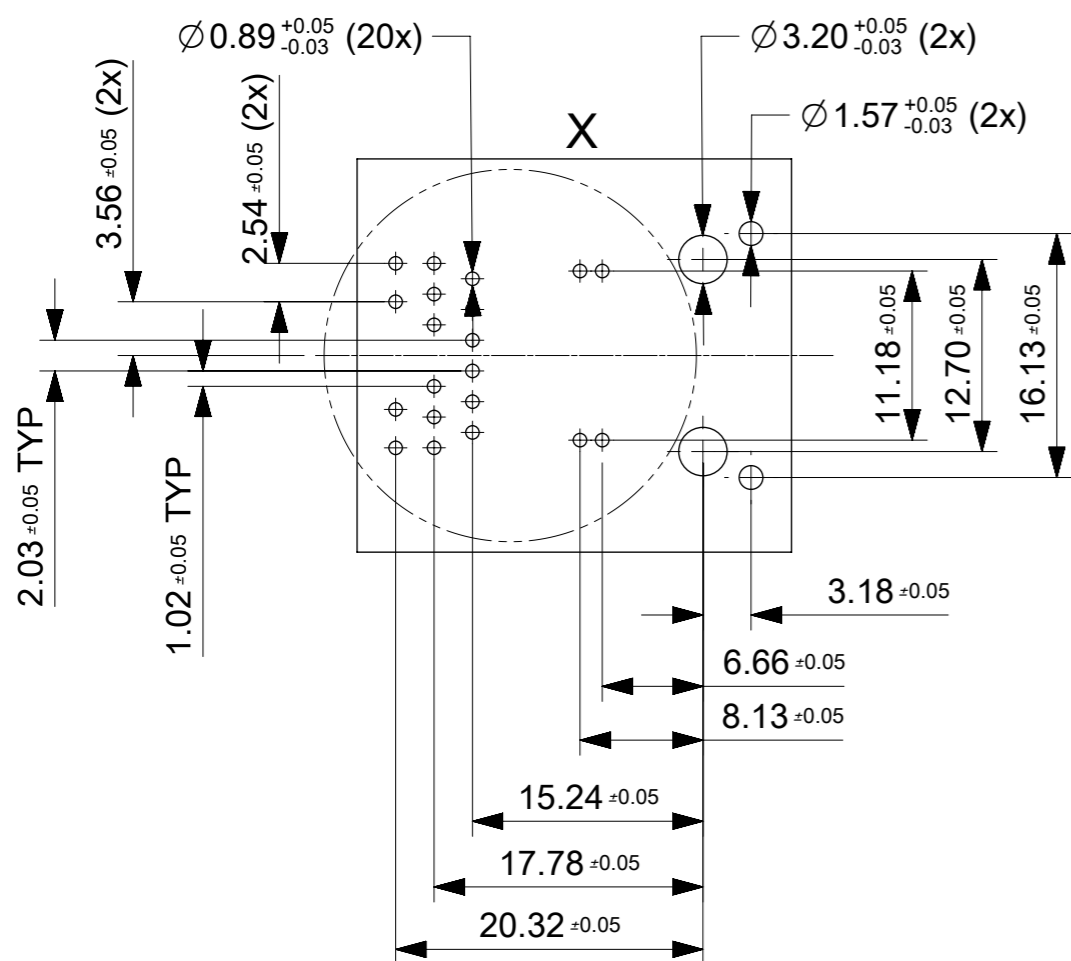

SUGGESTED BOARD LAYOUT FOR NON LED VERSION

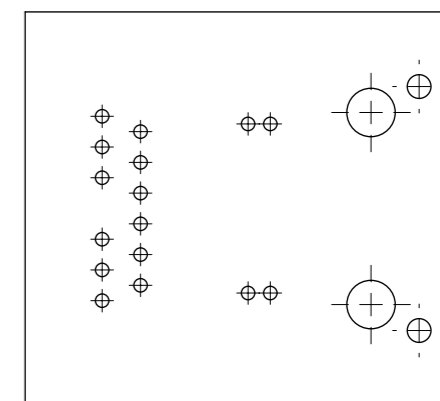

THIS DRAWING CONTAINS INFORMATION THAT IS PROPRIETARY TO MOLEX INCORPORATED AND SHOULD NOT BE USED WITHOUT WRITTEN PERMISSION												
EC DESCRIPTION EC NO: 102890 DRWN: MFURKEL CHK'D: REV: F	2015/09/28	2016/02/23	QUALITY SYMBOLS	GENERAL TOLERANCES (UNLESS SPECIFIED)	DIMENSION UNITS	SCALE	molex					
			▽ = 0	ANGULAR TOL ± 0.5 °	MM	2:1						
			▽ = 0	4 PLACES ±	DRWN BY	DATE	GIGABIT MAGNETIC JACK POE PLUS ENABLED					
			▽ = 0	3 PLACES ±	MFURKEL	2015/06/15						
▽ = 0	2 PLACES ± 0.25	CHK'D BY	DATE	PRODUCT CUSTOMER DRAWING								
▽ = 0	1 PLACE ± 0.5	APPR BY	DATE									
□ = 0	0 PLACES ±	DRAWING SIZE	THIRD ANGLE PROJECTION	SERIES	MATERIAL NUMBER	CUSTOMER	SEE BOM/SHEET 3/4					
■ = 0	DRAFT WHERE APPLICABLE MUST REMAIN WITHIN DIMENSIONS	A3		85789	857891001							
▽ = 0				DOCUMENT NUMBER	DOC TYPE	DOC PART	SHEET NUMBER	2 OF 4				
				857891001	PSD	000						

Electrical Specifications @25°C		
Operating temperature (0°C to +70°C)		
Description	VALUE	
OCL POE+TRANSF. 20mA bias (0°C to +70°C)	350µH min.	
OCL NONPOE TRANSF. 8mA bias (0°C to +70°C)	350µH min.	
Turns Ratio	1CT:1CT	
Insertion Loss		
Frequency (MHz)	Limits (dB max.)	Typical Values (dB max.)
1.0-9.9 MHz	0.4+0.1*log(F)	0.5 @ 10MHz
10-49.9 MHz	0.5+0.3*log(F/10)	0.7 @ 50MHz
50-79.9 MHz	1+1.4*log(F/80)	1.0 @ 80MHz
80-100 MHz	1.3+3*log(F/100)	1.3 @ 100MHz
Return Loss	Limits (dB min.)	TYPICAL Values (dB min.)
1-9.9 MHz	27dB min.	27 @ 10MHz
10-100 MHz	27-17*log(F/10)	10 @ 100MHz
CMR	Limits (dB min.)	TYPICAL Values (dB min.)
1-9.9 MHz	34dB min.	34 @ 10MHz
10-79.9 MHz	27dB min.	27 @ 80MHz
80-199.9 MHz	27-14.5*log(F/80)	21.5 @ 200MHz
200-399.9 MHz	21.5-39*log(F/200)	10 @ 400MHz
400-1000 MHz	10	10 @ 1000MHz
NEXT	Limits (dB min.)	TYPICAL Values (dB min.)
1-5.9 MHz	50	50 @ 6MHz
6-49.9 MHz	45-16*log(F/10)	34 @ 50MHz
50-100 MHz	25-30*log(F/100)	25 @ 100MHz
Isolation PHY to Wire side	2.25kVDC/60sec	

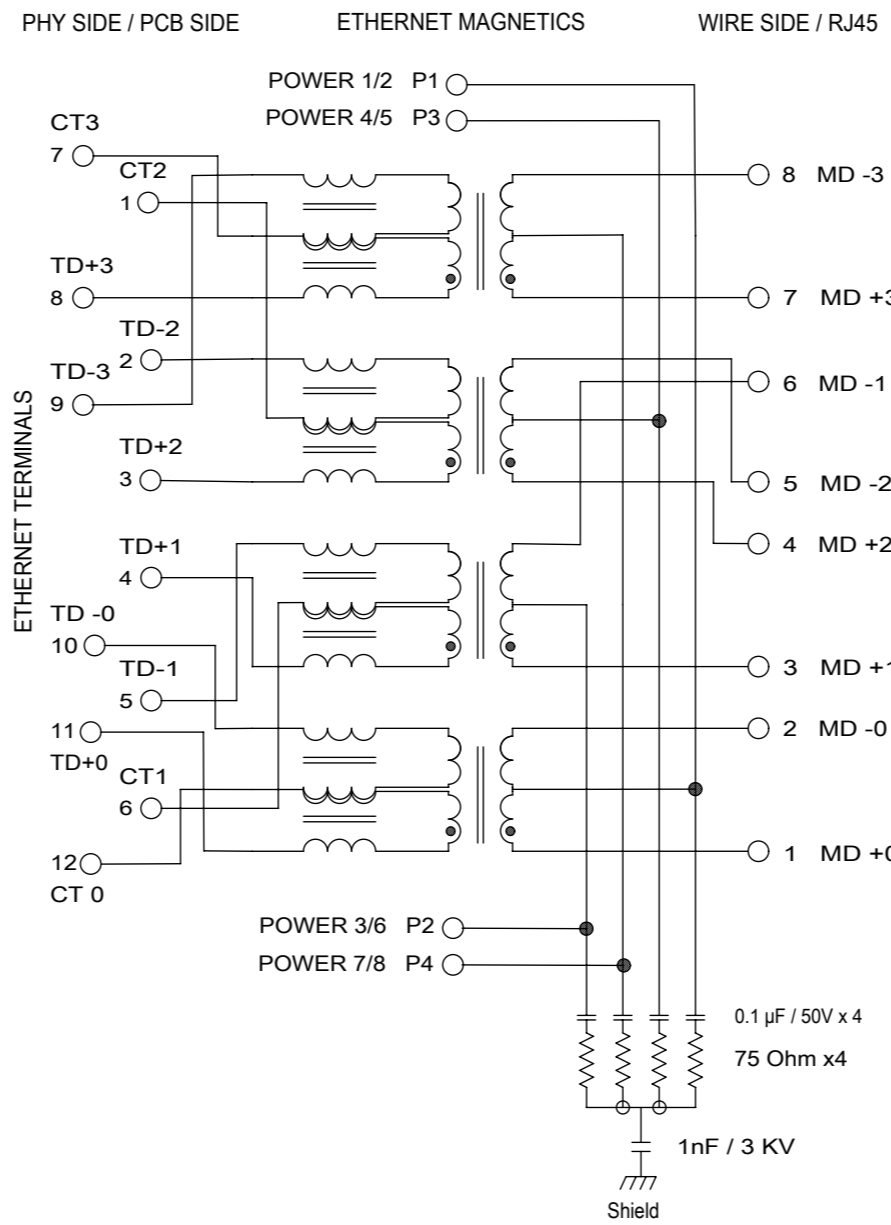

PART NUMBER	LED1 POLARITY			LED2 POLARITY		
	LEFT LED		COLOR	RIGHT LED		COLOR
	PIN15	PIN16		PIN13	PIN14	
857891001	-	+	GRN	-	+	GRN
857891003	-	+	GRN	-	+	GRN
857891006	-	+	GRN	-	+	YW
857891007	-	+	GRN	-	+	GRN
857891012	-	+	YW	-	+	GRN
857891013	-	+	YW	-	+	YW
857891014	-	+	GRN	+	-	GRN
857891015	-	+	YW	-	+	GRN
857891017	-	+	GRN	-	+	YW
857891020	NON LED					

ADDITIONAL LED COLORS AND CONFIGURATIONS ARE AVAILABLE ON REQUEST

SEE TABLE FOR LED OPTIONS

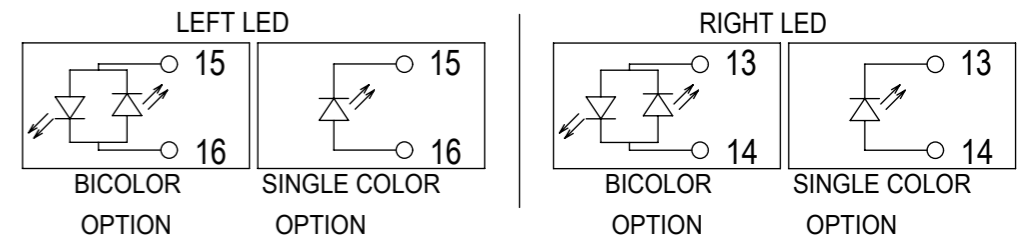

THIS DRAWING CONTAINS INFORMATION THAT IS PROPRIETARY TO MOLEX INCORPORATED AND SHOULD NOT BE USED WITHOUT WRITTEN PERMISSION

EC DESCRIPTION EC NO: 102890 DRWN: MFURKEL CHK'D: APPR: RSILLER REV: F	2015/09/28 2016/02/23	QUALITY SYMBOLS ▽ = 0 ▽ = 0 ▽ = 0 ▼ = 0 ▽ = 0 □ = 0 ■ = 0 ▽ = 0	GENERAL TOLERANCES (UNLESS SPECIFIED) ANGULAR TOL ± 0.5 ° 4 PLACES ± 3 PLACES ± 2 PLACES ± 0.25 1 PLACE ± 0.5 0 PLACES ± DRAFT WHERE APPLICABLE MUST REMAIN WITHIN DIMENSIONS	DIMENSION UNITS: MM SCALE: 5:1 DRWN BY: MFURKEL DATE: 2015/06/15 CHK'D BY: DATE: APPR BY: DATE: DRAWING SIZE: A3 THIRD ANGLE PROJECTION	
	PRODUCT CUSTOMER DRAWING			SERIES: 85789 MATERIAL NUMBER: SEE BOM/SHEET 3/4 CUSTOMER:	
	DOCUMENT NUMBER: 857891001		DOC TYPE: PSD DOC PART: 000 SHEET NUMBER: 3 OF 4		

Electrical Specifications @25°C		
Operating temperature (-40°C to +85°C)		
Description	VALUE	
OCL POE+TRANSF. 20mA bias (-40°C to +85°C)	350µH min.	
OCL NONPOE TRANSF. 8mA bias (-40°C to +85°C)	350µH min.	
Turns Ratio	1CT:1CT	
Insertion Loss		
Frequency (MHz)	Limits (dB max.)	Typical Values (dB max.)
1.0-9.9 MHz	0.4+0.1*log(F)	0.5 @ 10MHz
10-49.9 MHz	0.5+0.3*log(F/10)	0.7 @ 50MHz
50-79.9 MHz	1+1.4*log(F/80)	1.0 @ 80MHz
80-100 MHz	1.3+3*log(F/100)	1.3 @ 100MHz
Return Loss	Limits (dB min.)	TYPICAL Values (dB min.)
Frequency (MHz)		
1-9.9 MHz	27dB min.	27 @ 10MHz
10-100 MHz	27-17*log(F/10)	10 @ 100MHz
CMR	Limits (dB min.)	TYPICAL Values (dB min.)
Frequency (MHz)		
1-9.9 MHz	34dB min.	34 @ 10MHz
10-79.9 MHz	27dB min.	27 @ 80MHz
80-199.9 MHz	27-14.5*log(F/80)	21.5 @ 200MHz
200-399.9 MHz	21.5-39*log(F/200)	10 @ 400MHz
400-1000 MHz	10	10 @ 1000MHz
NEXT	Limits (dB min.)	TYPICAL Values (dB min.)
Frequency (MHz)		
1-5.9 MHz	50	50 @ 6MHz
6-49.9 MHz	45-16*log(F/10)	34 @ 50MHz
50-100 MHz	25-30*log(F/100)	25 @ 100MHz
Isolation PHY to Wire side	2.25kVDC/60sec	

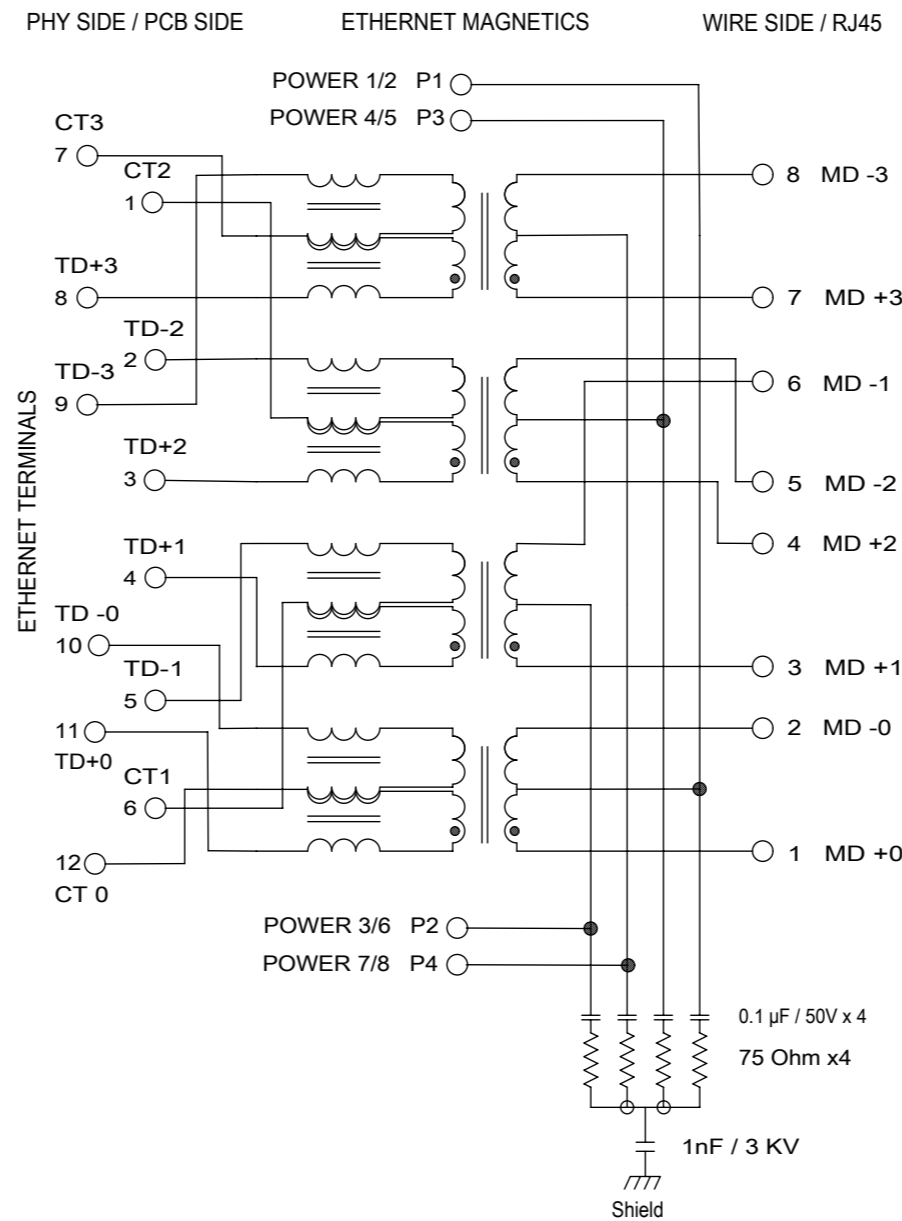

PART NUMBER	LED1 POLARITY			LED2 POLARITY		
	LEFT LED			RIGHT LED		
	PIN15	PIN16	COLOR	PIN13	PIN14	COLOR
857893006	-	+	GRN	-	+	YW
857893016	-	+	GRN	-	+	GRN
	+	-	YW			

ADDITIONAL LED COLORS AND CONFIGURATIONS ARE AVAILABLE ON REQUEST

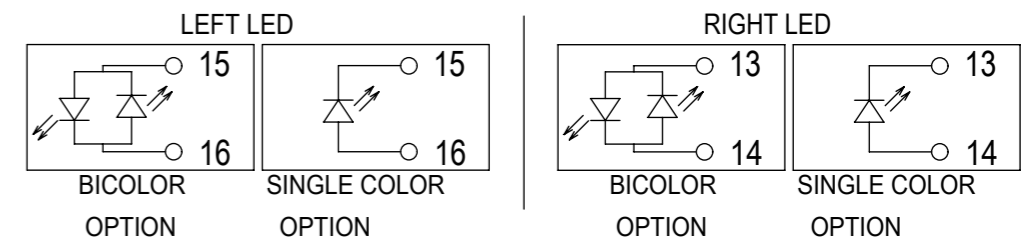

SEE TABLE FOR LED OPTIONS

THIS DRAWING CONTAINS INFORMATION THAT IS PROPRIETARY TO MOLEX INCORPORATED AND SHOULD NOT BE USED WITHOUT WRITTEN PERMISSION

EC DESCRIPTION EC NO: 102890 DRWN: MFURKEL CHK'D: APPR: RSILLER	2015/09/28	QUALITY SYMBOLS ▽ = 0 ▽ = 0 ▽ = 0 ▼ = 0 ▽ = 0 ☒ = 0 ■ = 0 ▽ = 0	GENERAL TOLERANCES (UNLESS SPECIFIED)		DIMENSION UNITS	SCALE	
			ANGULAR TOL ± 0.5 °		MM	5:1	
			4 PLACES ±	DRWN BY	DATE	GIGABIT MAGNETIC JACK POE PLUS ENABLED	
			3 PLACES ±	MFURKEL	2015/06/15		
	2 PLACES ± 0.25	CHK'D BY	DATE	PRODUCT CUSTOMER DRAWING			
	1 PLACE ± 0.5	APPR BY	DATE	SERIES MATERIAL NUMBER CUSTOMER			
	0 PLACES ±	DRAWING SIZE	THIRD ANGLE PROJECTION	85789 SEE BOM/SHEET 3/4			
	DRAFT WHERE APPLICABLE MUST REMAIN WITHIN DIMENSIONS	A3		DOCUMENT NUMBER DOC TYPE DOC PART SHEET NUMBER			
				857891001 PSD 000 4 OF 4			