



Chipsmall Limited consists of a professional team with an average of over 10 year of expertise in the distribution of electronic components. Based in Hongkong, we have already established firm and mutual-benefit business relationships with customers from,Europe,America and south Asia,supplying obsolete and hard-to-find components to meet their specific needs.

With the principle of “Quality Parts,Customers Priority,Honest Operation,and Considerate Service”,our business mainly focus on the distribution of electronic components. Line cards we deal with include Microchip,ALPS,ROHM,Xilinx,Pulse,ON,Everlight and Freescale. Main products comprise IC,Modules,Potentiometer,IC Socket,Relay,Connector.Our parts cover such applications as commercial,industrial, and automotives areas.

We are looking forward to setting up business relationship with you and hope to provide you with the best service and solution. Let us make a better world for our industry!



## Contact us

Tel: +86-755-8981 8866 Fax: +86-755-8427 6832

Email & Skype: info@chipsmall.com Web: www.chipsmall.com

Address: A1208, Overseas Decoration Building, #122 Zhenhua RD., Futian, Shenzhen, China



10 9 8 7 6 5 4 3 2 1

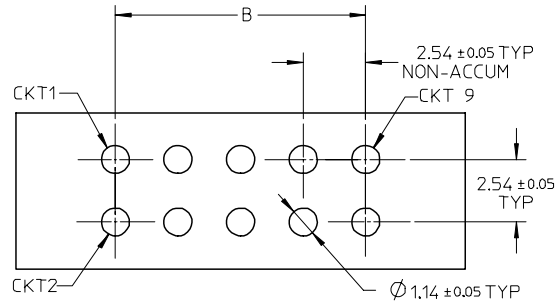
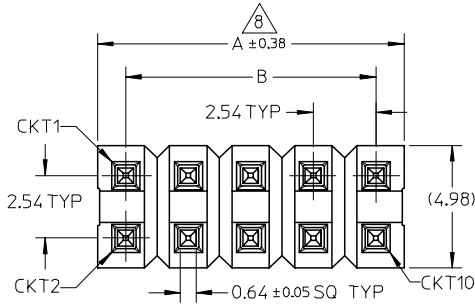

RECOMMENDED PCB LAYOUT

- NOTES:
- MATERIAL:  
HSG: LCP, GLASS-FILLED, UL94V-0, COLOR: BLACK  
PIN: 0.64MM SQ PIN, COPPER ALLOY
  - PLATING TYPE:  
(1) : 0.381 μm MIN. GOLD PLATE ON CONTACT AND 1.905 μm MIN. TIN ON SOLDERTAIL OVER 1.270 μm MIN. NICKEL OVERALL.  
(2) : 0.762 μm MIN. GOLD PLATE ON CONTACT AND 1.905 μm MIN. TIN ON SOLDERTAIL OVER 1.270 μm MIN. NICKEL OVERALL.  
(3) : 2.540 μm MIN. TIN IN SELECTED AREA OVER 1.270 μm MIN. NICKEL OVERALL.
  - THE ABOVE 10 CKT IS FOR ILLUSTRATION PURPOSE ONLY.
  - FOR PACKAGING OPTION PLEASE REFER TO THE TABLE.
  - RECOMMENDED PCB THICKNESS 1.60MM.
  - PRODUCT SPECIFICATION: PS-87920-019
  - WAFER TO BE FLAT WITHIN 0.003mm/mm
  - IRREGULAR CIRCUIT CUTOFF WITHIN BREAKAWAY SECTION IS PERMISSIBLE. CUTTING OR CHIPPING OF THE MAIN BODY IS NOT ACCEPTABLE.
  - PARTS ARE NOT STACKABLE ON 2.54 CENTER
  - PACKAGING SPECIFICATION:  
TRAY: PK-89990-489  
BULK: PK-89990-491

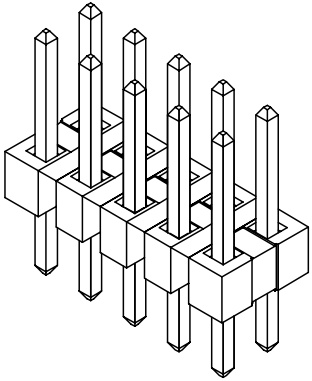
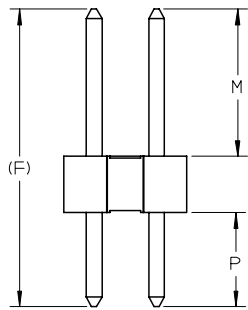
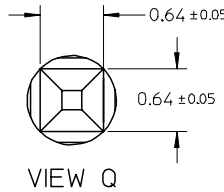
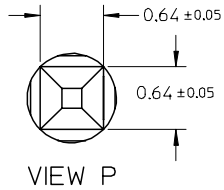
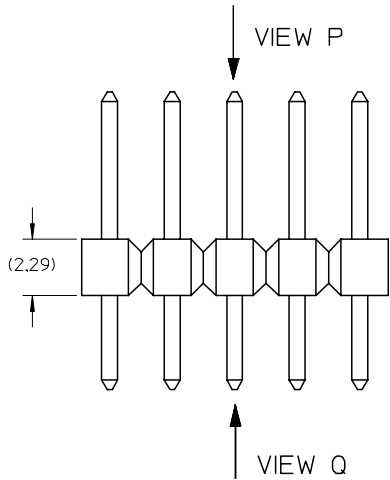

EWR# 1010 & 1021 EC NO: S2007-0182 DRWNS:SKL IM01 2006/09/11 CHKD:CWLAM 2006/09/12 APPR:KWLEE 2006/09/13	QUALITY SYMBOLS	GENERAL TOLERANCES (UNLESS SPECIFIED)		DIMENSION STYLE	SCALE	DESIGN UNITS	THIRD ANGLE PROJECTION	
	▼=0 ▽=0	mm	INCH	MM ONLY	NTS	METRIC		
	DESCRIPTION	4 PLACES	± ---	± ---	DRAWN BY	DATE	TITLE	
	REV	3 PLACES	± ---	± ---	SKL IM01	2006/08/21	CUSTOM HEADER C-GRID, SINGLE WAFER HDR, THROUGH HOLE, VERTICAL, LF	
	2 PLACES	± 0.2	± ---	CHECKED BY	DATE	MOLEX INCORPORATED		
	1 PLACE	± ---	± ---	CWLAM	2006/09/04		SD-87914-059	
			ANGULAR ± 3 °	APPROVED BY	DATE	SHEET NO.		
				KWLEE	2006/09/04	1 OF 9		
				MATERIAL NO.	DOCUMENT NO.			
				SEE TABLE				
				DRAFT WHERE APPLICABLE MUST REMAIN WITHIN DIMENSIONS				
				THIS DRAWING CONTAINS INFORMATION THAT IS PROPRIETARY TO MOLEX INCORPORATED AND SHOULD NOT BE USED WITHOUT WRITTEN PERMISSION				

9 8 7 6 5 4 3 2 1

PART NO FOR TRAY PACKAGING	PART NO FOR BULK PACKAGING	CKT SIZE	PLATING TYPE	DIMENSION				
				A	B	F	MATING END	SOLDER TAIL
							M	P
87914-0401	-----	4	1	5.08	2.54	13.21	8.13	2.79
87914-0402	-----	4	2	5.08	2.54	13.21	8.13	2.79
87914-0403	-----	4	3	5.08	2.54	13.21	8.13	2.79
87914-0601	-----	6	1	7.62	5.08	13.21	8.13	2.79
87914-0602	-----	6	2	7.62	5.08	13.21	8.13	2.79
87914-0603	-----	6	3	7.62	5.08	13.21	8.13	2.79
87914-0801	-----	8	1	10.16	7.62	13.21	8.13	2.79
87914-0802	-----	8	2	10.16	7.62	13.21	8.13	2.79
87914-0803	-----	8	3	10.16	7.62	13.21	8.13	2.79
87914-1001	-----	10	1	12.70	10.16	13.21	8.13	2.79
87914-1002	-----	10	2	12.70	10.16	13.21	8.13	2.79
87914-1003	-----	10	3	12.70	10.16	13.21	8.13	2.79

PART NO FOR TRAY PACKAGING	PART NO FOR BULK PACKAGING	CKT SIZE	PLATING TYPE	DIMENSION				
				A	B	F	MATING END	SOLDER TAIL
							M	P
87914-0204	-----	2	1	2.54	---	11.11	6.10	2.72
87914-0205	-----	2	2	2.54	---	11.11	6.10	2.72
87914-0206	-----	2	3	2.54	---	11.11	6.10	2.72
87914-0404	-----	4	1	5.08	2.54	11.11	6.10	2.72
87914-0405	-----	4	2	5.08	2.54	11.11	6.10	2.72
87914-0406	-----	4	3	5.08	2.54	11.11	6.10	2.72
87914-0604	-----	6	1	7.62	5.08	11.11	6.10	2.72
87914-0605	-----	6	2	7.62	5.08	11.11	6.10	2.72
87914-0606	-----	6	3	7.62	5.08	11.11	6.10	2.72
87914-0804	-----	8	1	10.16	7.62	11.11	6.10	2.72
87914-0805	-----	8	2	10.16	7.62	11.11	6.10	2.72
87914-0806	-----	8	3	10.16	7.62	11.11	6.10	2.72
87914-1004	-----	10	1	12.70	10.16	11.11	6.10	2.72
87914-1005	-----	10	2	12.70	10.16	11.11	6.10	2.72
87914-1006	-----	10	3	12.70	10.16	11.11	6.10	2.72

EWR# 1010 & 1021  
 EC NO: S2007-0182  
 DRWNS:SKLIM01 2006/09/11  
 CHKD:CWLAM 2006/09/12  
 APPR:KWLEE 2006/09/13

QUALITY SYMBOLS  
 ▼=0  
 ▽=0

GENERAL TOLERANCES (UNLESS SPECIFIED)  

	mm	INCH
4 PLACES	± ---	± ---
3 PLACES	± ---	± ---
2 PLACES	± 0.2	± ---
1 PLACE	± ---	± ---
ANGULAR ± 3 °		

 DRAFT WHERE APPLICABLE  
 MUST REMAIN WITHIN DIMENSIONS

DIMENSION STYLE  
 MM ONLY  
 DRAWN BY SKLIM01 DATE 2006/08/21  
 CHECKED BY CWLAM DATE 2006/09/04  
 APPROVED BY KWLEE DATE 2006/09/04  
 MATERIAL NO. SEE TABLE

SCALE NTS  
 DESIGN UNITS METRIC  
 THIRD ANGLE PROJECTION  
 TITLE  
 CUSTOM HEADER  
 C-GRID, SINGLE WAFER HDR,  
 THROU HOLE, VERTICAL, LF  
 MOLEX INCORPORATED  
 DOCUMENT NO. SD-87914-059  
 SHEET NO. 2 OF 9  
 THIS DRAWING CONTAINS INFORMATION THAT IS PROPRIETARY TO MOLEX INCORPORATED AND SHOULD NOT BE USED WITHOUT WRITTEN PERMISSION

10 9 8 7 6 5 4 3 2 1

	PART NO FOR TRAY PACKAGING	PART NO FOR BULK PACKAGING	CKT SIZE	PLATING TYPE	DIMENSION				
					A	B	F	MATING END	SOLDER TAIL
								M	P
F	87914-1201	-----	12	1	15.24	12.70	13.21	8.13	2.79
	87914-1202	-----	12	2	15.24	12.70	13.21	8.13	2.79
	87914-1203	-----	12	3	15.24	12.70	13.21	8.13	2.79
E	87914-1401	-----	14	1	17.78	15.24	13.21	8.13	2.79
	87914-1402	-----	14	2	17.78	15.24	13.21	8.13	2.79
	87914-1403	-----	14	3	17.78	15.24	13.21	8.13	2.79
	87914-1601	-----	16	1	20.32	17.78	13.21	8.13	2.79
	87914-1602	-----	16	2	20.32	17.78	13.21	8.13	2.79
	87914-1603	-----	16	3	20.32	17.78	13.21	8.13	2.79
D	87914-1801	-----	18	1	22.86	20.32	13.21	8.13	2.79
	87914-1802	-----	18	2	22.86	20.32	13.21	8.13	2.79
	87914-1803	-----	18	3	22.86	20.32	13.21	8.13	2.79
	87914-2001	-----	20	1	25.40	22.86	13.21	8.13	2.79
	87914-2002	-----	20	2	25.40	22.86	13.21	8.13	2.79
C	87914-2003	-----	20	3	25.40	22.86	13.21	8.13	2.79

	PART NO FOR TRAY PACKAGING	PART NO FOR BULK PACKAGING	CKT SIZE	PLATING TYPE	DIMENSION				
					A	B	F	MATING END	SOLDER TAIL
								M	P
F	87914-1204	-----	12	1	15.24	12.70	11.11	6.10	2.72
	87914-1205	-----	12	2	15.24	12.70	11.11	6.10	2.72
	87914-1206	-----	12	3	15.24	12.70	11.11	6.10	2.72
E	87914-1404	-----	14	1	17.78	15.24	11.11	6.10	2.72
	87914-1405	-----	14	2	17.78	15.24	11.11	6.10	2.72
	87914-1406	-----	14	3	17.78	15.24	11.11	6.10	2.72
	87914-1604	-----	16	1	20.32	17.78	11.11	6.10	2.72
	87914-1605	-----	16	2	20.32	17.78	11.11	6.10	2.72
	87914-1606	-----	16	3	20.32	17.78	11.11	6.10	2.72
D	87914-1804	-----	18	1	22.86	20.32	11.11	6.10	2.72
	87914-1805	-----	18	2	22.86	20.32	11.11	6.10	2.72
	87914-1806	-----	18	3	22.86	20.32	11.11	6.10	2.72
	87914-2004	-----	20	1	25.40	22.86	11.11	6.10	2.72
	87914-2005	-----	20	2	25.40	22.86	11.11	6.10	2.72
C	87914-2006	-----	20	3	25.40	22.86	11.11	6.10	2.72

B B

A	EWB# 1010 & 1021	DESCRIPTION	QUALITY SYMBOLS
	EC NO: S2007-0182		$\nabla = 0$ $\triangle = 0$
	DRWNS:SKLIM01 2006/09/11 CHKD:CWLAM 2006/09/12 APPR:KWLEE 2006/09/13		REV

GENERAL TOLERANCES (UNLESS SPECIFIED)	DIMENSION STYLE MM ONLY	SCALE NTS	DESIGN UNITS METRIC	THIRD ANGLE PROJECTION																								
<table border="1"> <tr><td>4 PLACES</td><td>± ---</td><td>± ---</td></tr> <tr><td>3 PLACES</td><td>± ---</td><td>± ---</td></tr> <tr><td>2 PLACES</td><td>± 0.2</td><td>± ---</td></tr> <tr><td>1 PLACE</td><td>± ---</td><td>± ---</td></tr> </table>	4 PLACES	± ---	± ---	3 PLACES	± ---	± ---	2 PLACES	± 0.2	± ---	1 PLACE	± ---	± ---	<table border="1"> <tr><td>DRAWN BY</td><td>DATE</td></tr> <tr><td>SKLIM01</td><td>2006/08/21</td></tr> <tr><td>CHECKED BY</td><td>DATE</td></tr> <tr><td>CWLAM</td><td>2006/09/04</td></tr> <tr><td>APPROVED BY</td><td>DATE</td></tr> <tr><td>KWLEE</td><td>2006/09/04</td></tr> </table>	DRAWN BY	DATE	SKLIM01	2006/08/21	CHECKED BY	DATE	CWLAM	2006/09/04	APPROVED BY	DATE	KWLEE	2006/09/04	TITLE CUSTOM HEADER C-GRID, SINGLE WAFER HDR, THROUGH HOLE, VERTICAL, LF		
4 PLACES	± ---	± ---																										
3 PLACES	± ---	± ---																										
2 PLACES	± 0.2	± ---																										
1 PLACE	± ---	± ---																										
DRAWN BY	DATE																											
SKLIM01	2006/08/21																											
CHECKED BY	DATE																											
CWLAM	2006/09/04																											
APPROVED BY	DATE																											
KWLEE	2006/09/04																											
ANGULAR ± 3°	MATERIAL NO.	DOCUMENT NO.	MOLEX INCORPORATED																									
DRAFT WHERE APPLICABLE MUST REMAIN WITHIN DIMENSIONS	SIZE A3	SEE TABLE	SD-87914-059	SHEET NO. 3 OF 9																								

id\_frame\_A3\_P\_AM\_T Rev. D 2004/06/28 9 8 7 6 5 4 3 2 1 A





F	PART NO FOR TRAY PACKAGING	PART NO FOR BULK PACKAGING	CKT SIZE	PLATING TYPE	DIMENSION					PART NO FOR TRAY PACKAGING	PART NO FOR BULK PACKAGING	CKT SIZE	PLATING TYPE	DIMENSION					F	
					A	B	F	M	P					A	B	F	M	P		E
	87914-2201	-----	22	1	27.94	25.40	13.21	8.13	2.79	87914-2204	-----	22	1	27.94	25.40	11.11	6.10	2.72		
	87914-2202	-----	22	2	27.94	25.40	13.21	8.13	2.79	87914-2205	-----	22	2	27.94	25.40	11.11	6.10	2.72		
	87914-2203	-----	22	3	27.94	25.40	13.21	8.13	2.79	87914-2206	-----	22	3	27.94	25.40	11.11	6.10	2.72		
	87914-2401	-----	24	1	30.48	27.94	13.21	8.13	2.79	87914-2404	-----	24	1	30.48	27.94	11.11	6.10	2.72		
	87914-2402	-----	24	2	30.48	27.94	13.21	8.13	2.79	87914-2405	-----	24	2	30.48	27.94	11.11	6.10	2.72		
	87914-2403	-----	24	3	30.48	27.94	13.21	8.13	2.79	87914-2406	-----	24	3	30.48	27.94	11.11	6.10	2.72		
	87914-2601	-----	26	1	33.02	30.48	13.21	8.13	2.79	87914-2604	-----	26	1	33.02	30.48	11.11	6.10	2.72		
	87914-2602	-----	26	2	33.02	30.48	13.21	8.13	2.79	87914-2605	-----	26	2	33.02	30.48	11.11	6.10	2.72		
	87914-2603	-----	26	3	33.02	30.48	13.21	8.13	2.79	87914-2606	-----	26	3	33.02	30.48	11.11	6.10	2.72		
	87914-2801	-----	28	1	35.56	33.02	13.21	8.13	2.79	87914-2804	-----	28	1	35.56	33.02	11.11	6.10	2.72		
	87914-2802	-----	28	2	35.56	33.02	13.21	8.13	2.79	87914-2805	-----	28	2	35.56	33.02	11.11	6.10	2.72		
	87914-2803	-----	28	3	35.56	33.02	13.21	8.13	2.79	87914-2806	-----	28	3	35.56	33.02	11.11	6.10	2.72		
	87914-3001	-----	30	1	38.10	35.56	13.21	8.13	2.79	87914-3004	-----	30	1	38.10	35.56	11.11	6.10	2.72		
	87914-3002	-----	30	2	38.10	35.56	13.21	8.13	2.79	87914-3005	-----	30	2	38.10	35.56	11.11	6.10	2.72		
	87914-3003	-----	30	3	38.10	35.56	13.21	8.13	2.79	87914-3006	-----	30	3	38.10	35.56	11.11	6.10	2.72		

B											B
---	--	--	--	--	--	--	--	--	--	--	---

EWR# 1010 & 1021 EC NO: S2007-0182 DRWNS:SKL IM01 2006/09/11 CHKD:CWLAM 2006/09/12 APPR:KWLEE 2006/09/13	QUALITY SYMBOLS ▽=0 ▽=0	GENERAL TOLERANCES (UNLESS SPECIFIED)		DIMENSION STYLE MM ONLY		SCALE NTS	DESIGN UNITS METRIC	THIRD ANGLE PROJECTION		
				4 PLACES ± --- ± ---	DRAWN BY SKL IM01 DATE 2006/08/21		CUSTOM HEADER C-GRID, SINGLE WAFER HDR, THROU HOLE, VERTICAL, LF MOLEX INCORPORATED			
				3 PLACES ± --- ± ---	CHECKED BY CWLAM DATE 2006/09/04					
				2 PLACES ± 0.2 ± ---	APPROVED BY KWLEE DATE 2006/09/04		MATERIAL NO.		DOCUMENT NO.	SHEET NO.
		1 PLACE ± --- ± ---	ANGULAR ± 3 °		SEE TABLE		SD-87914-059	4 OF 9		
		DRAFT WHERE APPLICABLE MUST REMAIN WITHIN DIMENSIONS		SIZE A3		THIS DRAWING CONTAINS INFORMATION THAT IS PROPRIETARY TO MOLEX INCORPORATED AND SHOULD NOT BE USED WITHOUT WRITTEN PERMISSION				

	10		9		8			7		6		5		4		3			2		1																
	PART NO FOR TRAY PACKAGING	PART NO FOR BULK PACKAGING	CKT SIZE	PLATING TYPE	DIMENSION					PART NO FOR TRAY PACKAGING	PART NO FOR BULK PACKAGING	CKT SIZE	PLATING TYPE	DIMENSION					PART NO FOR TRAY PACKAGING	PART NO FOR BULK PACKAGING	CKT SIZE	PLATING TYPE	DIMENSION														
					A	B	F	M	P					A	B	F	M	P					A	B	F	M	P										
F	87914-3201	-----	32	1	40.64	38.10	13.21	8.13	2.79	87914-3204	-----	32	1	40.64	38.10	11.11	6.10	2.72	87914-3205	-----	32	2	40.64	38.10	11.11	6.10	2.72	87914-3206	-----	32	3	40.64	38.10	11.11	6.10	2.72	
	87914-3401	-----	34	1	43.18	40.64	13.21	8.13	2.79	87914-3404	-----	34	1	43.18	40.64	11.11	6.10	2.72	87914-3405	-----	34	2	43.18	40.64	11.11	6.10	2.72	87914-3406	-----	34	3	43.18	40.64	11.11	6.10	2.72	
E	87914-3402	-----	34	2	43.18	40.64	13.21	8.13	2.79																												
	87914-3403	-----	34	3	43.18	40.64	13.21	8.13	2.79																												
	87914-3601	-----	36	1	45.72	43.18	13.21	8.13	2.79	87914-3604	-----	36	1	45.72	43.18	11.11	6.10	2.72	87914-3605	-----	36	2	45.72	43.18	11.11	6.10	2.72	87914-3606	-----	36	3	45.72	43.18	11.11	6.10	2.72	
	87914-3602	-----	36	2	45.72	43.18	13.21	8.13	2.79																												
	87914-3603	-----	36	3	45.72	43.18	13.21	8.13	2.79																												
D																																					
	87914-3801	-----	38	1	48.26	45.72	13.21	8.13	2.79	87914-3804	-----	38	1	48.26	45.72	11.11	6.10	2.72	87914-3805	-----	38	2	48.26	45.72	11.11	6.10	2.72	87914-3806	-----	38	3	48.26	45.72	11.11	6.10	2.72	
	87914-3802	-----	38	2	48.26	45.72	13.21	8.13	2.79																												
	87914-3803	-----	38	3	48.26	45.72	13.21	8.13	2.79																												
	87914-4001	-----	40	1	50.80	48.26	13.21	8.13	2.79	87914-4004	-----	40	1	50.80	48.26	11.11	6.10	2.72	87914-4005	-----	40	2	50.80	48.26	11.11	6.10	2.72	87914-4006	-----	40	3	50.80	48.26	11.11	6.10	2.72	
C	87914-4002	-----	40	2	50.80	48.26	13.21	8.13	2.79																												
	87914-4003	-----	40	3	50.80	48.26	13.21	8.13	2.79																												

B

A	EWR# 1010 & 1021 EC NO: S2007-0182 DRWNS:SKL M01 2006/09/11 CHKD:CWLAM 2006/09/12 APPR:KWLEE 2006/09/13	QUALITY SYMBOLS  = 0  = 0	GENERAL TOLERANCES (UNLESS SPECIFIED) <table border="1"> <tr> <th></th> <th>mm</th> <th>INCH</th> </tr> <tr> <td>4 PLACES</td> <td>± ---</td> <td>± ---</td> </tr> <tr> <td>3 PLACES</td> <td>± ---</td> <td>± ---</td> </tr> <tr> <td>2 PLACES</td> <td>± 0.2</td> <td>± ---</td> </tr> <tr> <td>1 PLACE</td> <td>± ---</td> <td>± ---</td> </tr> <tr> <td colspan="3">ANGULAR ± 3°</td> </tr> </table>		mm	INCH	4 PLACES	± ---	± ---	3 PLACES	± ---	± ---	2 PLACES	± 0.2	± ---	1 PLACE	± ---	± ---	ANGULAR ± 3°			DIMENSION STYLE MM ONLY DRAWN BY SKL M01 DATE 2006/08/21 CHECKED BY CWLAM DATE 2006/09/04 APPROVED BY KWLEE DATE 2006/09/04	SCALE NTS DESIGN UNITS METRIC  THIRD ANGLE PROJECTION	TITLE CUSTOM HEADER C-GRID, SINGLE WAFER HDR, THROU HOLE, VERTICAL, LF  MOLEX INCORPORATED	MATERIAL NO. DOCUMENT NO. SD-87914-059 SHEET NO. 5 OF 9
			mm	INCH																					
		4 PLACES	± ---	± ---																					
3 PLACES	± ---	± ---																							
2 PLACES	± 0.2	± ---																							
1 PLACE	± ---	± ---																							
ANGULAR ± 3°																									
DRAFT WHERE APPLICABLE MUST REMAIN WITHIN DIMENSIONS	SEE TABLE	THIS DRAWING CONTAINS INFORMATION THAT IS PROPRIETARY TO MOLEX INCORPORATED AND SHOULD NOT BE USED WITHOUT WRITTEN PERMISSION																							
SIZE A3																									



	10		9		8		7		6		5		4		3		2		1	
	PART NO FOR TRAY PACKAGING	PART NO FOR BULK PACKAGING	CKT SIZE	PLATING TYPE	DIMENSION					PART NO FOR TRAY PACKAGING	PART NO FOR BULK PACKAGING	CKT SIZE	PLATING TYPE	DIMENSION						
					A	B	F	M	P					A	B	F	M	P		
F	87914-4201	-----	42	1	53.34	50.80	13.21	8.13	2.79	87914-4204	-----	42	1	53.34	50.80	11.11	6.10	2.72		
	87914-4202	-----	42	2	53.34	50.80	13.21	8.13	2.79	87914-4205	-----	42	2	53.34	50.80	11.11	6.10	2.72		
	87914-4203	-----	42	3	53.34	50.80	13.21	8.13	2.79	87914-4206	-----	42	3	53.34	50.80	11.11	6.10	2.72		
	87914-4401	-----	44	1	55.88	53.34	13.21	8.13	2.79	87914-4404	-----	44	1	55.88	53.34	11.11	6.10	2.72		
	87914-4402	-----	44	2	55.88	53.34	13.21	8.13	2.79	87914-4405	-----	44	2	55.88	53.34	11.11	6.10	2.72		
E	87914-4403	-----	44	3	55.88	53.34	13.21	8.13	2.79	87914-4406	-----	44	3	55.88	53.34	11.11	6.10	2.72		
	87914-4601	-----	46	1	58.42	55.88	13.21	8.13	2.79	87914-4604	-----	46	1	58.42	55.88	11.11	6.10	2.72		
	87914-4602	-----	46	2	58.42	55.88	13.21	8.13	2.79	87914-4605	-----	46	2	58.42	55.88	11.11	6.10	2.72		
	87914-4603	-----	46	3	58.42	55.88	13.21	8.13	2.79	87914-4606	-----	46	3	58.42	55.88	11.11	6.10	2.72		
D	87914-4801	-----	48	1	60.96	58.42	13.21	8.13	2.79	87914-4804	-----	48	1	60.96	58.42	11.11	6.10	2.72		
	87914-4802	-----	48	2	60.96	58.42	13.21	8.13	2.79	87914-4805	-----	48	2	60.96	58.42	11.11	6.10	2.72		
	87914-4803	-----	48	3	60.96	58.42	13.21	8.13	2.79	87914-4806	-----	48	3	60.96	58.42	11.11	6.10	2.72		
	87914-5001	-----	50	1	63.50	60.96	13.21	8.13	2.79	87914-5004	-----	50	1	63.50	60.96	11.11	6.10	2.72		
	87914-5002	-----	50	2	63.50	60.96	13.21	8.13	2.79	87914-5005	-----	50	2	63.50	60.96	11.11	6.10	2.72		
C	87914-5003	-----	50	3	63.50	60.96	13.21	8.13	2.79	87914-5006	-----	50	3	63.50	60.96	11.11	6.10	2.72		

B

<b>EWR# 1010 &amp; 1021</b> EC NO: S2007-0182 DRWNS:SKL IM01 2006/09/11 CHKD:CWLAM 2006/09/12 APPR:KWLEE 2006/09/13	QUALITY SYMBOLS =0 =0	GENERAL TOLERANCES (UNLESS SPECIFIED)	DIMENSION STYLE <b>MM ONLY</b>	SCALE NTS	DESIGN UNITS METRIC	THIRD ANGLE PROJECTION		
		4 PLACES ± --- ± --- 3 PLACES ± --- ± --- 2 PLACES ± 0.2 ± --- 1 PLACE ± --- ± ---	DIMENSION STYLE mm INCH	DRAWN BY SKL IM01	DATE 2006/08/21	TITLE <b>CUSTOM HEADER          C-GRID, SINGLE WAFER HDR,          THROU HOLE, VERTICAL, LF</b>		
		ANGULAR ± 3 °	APPROVED BY KWLEE	DATE 2006/09/04	<b>MOLEX INCORPORATED</b>			
		DRAFT WHERE APPLICABLE MUST REMAIN WITHIN DIMENSIONS	MATERIAL NO. <b>SEE TABLE</b>	DOCUMENT NO. <b>SD-87914-059</b>	SHEET NO. <b>6 OF 9</b>			

F	10		9		8		7		6		5		4		3		2		1	
	PART NO FOR TRAY PACKAGING	PART NO FOR BULK PACKAGING	CKT SIZE	PLATING TYPE	DIMENSION					PART NO FOR TRAY PACKAGING	PART NO FOR BULK PACKAGING	CKT SIZE	PLATING TYPE	DIMENSION						
					A	B	F	M	P					A	B	F	M	P		
	-----	87914-5201	52	1	66.04	63.50	13.21	8.13	2.79	-----	87914-5204	52	1	66.04	63.50	11.11	6.10	2.72		
	-----	87914-5202	52	2	66.04	63.50	13.21	8.13	2.79	-----	87914-5205	52	2	66.04	63.50	11.11	6.10	2.72		
	-----	87914-5203	52	3	66.04	63.50	13.21	8.13	2.79	-----	87914-5206	52	3	66.04	63.50	11.11	6.10	2.72		
	-----	87914-5401	54	1	68.58	66.04	13.21	8.13	2.79	-----	87914-5404	54	1	68.58	66.04	11.11	6.10	2.72		
	-----	87914-5402	54	2	68.58	66.04	13.21	8.13	2.79	-----	87914-5405	54	2	68.58	66.04	11.11	6.10	2.72		
	-----	87914-5403	54	3	68.58	66.04	13.21	8.13	2.79	-----	87914-5406	54	3	68.58	66.04	11.11	6.10	2.72		
	-----	87914-5601	56	1	71.12	68.58	13.21	8.13	2.79	-----	87914-5604	56	1	71.12	68.58	11.11	6.10	2.72		
	-----	87914-5602	56	2	71.12	68.58	13.21	8.13	2.79	-----	87914-5605	56	2	71.12	68.58	11.11	6.10	2.72		
	-----	87914-5603	56	3	71.12	68.58	13.21	8.13	2.79	-----	87914-5606	56	3	71.12	68.58	11.11	6.10	2.72		
	-----	87914-5801	58	1	73.66	71.12	13.21	8.13	2.79	-----	87914-5804	58	1	73.66	71.12	11.11	6.10	2.72		
	-----	87914-5802	58	2	73.66	71.12	13.21	8.13	2.79	-----	87914-5805	58	2	73.66	71.12	11.11	6.10	2.72		
	-----	87914-5803	58	3	73.66	71.12	13.21	8.13	2.79	-----	87914-5806	58	3	73.66	71.12	11.11	6.10	2.72		
	-----	87914-6001	60	1	76.20	73.66	13.21	8.13	2.79	-----	87914-6004	60	1	76.20	73.66	11.11	6.10	2.72		
	-----	87914-6002	60	2	76.20	73.66	13.21	8.13	2.79	-----	87914-6005	60	2	76.20	73.66	11.11	6.10	2.72		
	-----	87914-6003	60	3	76.20	73.66	13.21	8.13	2.79	-----	87914-6006	60	3	76.20	73.66	11.11	6.10	2.72		

B																			
---	--	--	--	--	--	--	--	--	--	--	--	--	--	--	--	--	--	--	--

A	EWR# 1010 & 1021 EC NO: S2007-0182 DRWNS:SKL IM01 2006/09/11 CHKD:CWLAM 2006/09/12 APPR:KWLEE 2006/09/13	QUALITY SYMBOLS =0 =0	GENERAL TOLERANCES (UNLESS SPECIFIED) <table border="1"> <tr> <th></th> <th>mm</th> <th>INCH</th> </tr> <tr> <td>4 PLACES</td> <td>± .005</td> <td>± .0004</td> </tr> <tr> <td>3 PLACES</td> <td>± .005</td> <td>± .0004</td> </tr> <tr> <td>2 PLACES</td> <td>± 0.2</td> <td>± .008</td> </tr> <tr> <td>1 PLACE</td> <td>± .005</td> <td>± .0004</td> </tr> </table>		mm	INCH	4 PLACES	± .005	± .0004	3 PLACES	± .005	± .0004	2 PLACES	± 0.2	± .008	1 PLACE	± .005	± .0004	DIMENSION STYLE MM ONLY	SCALE NTS	DESIGN UNITS METRIC	THIRD ANGLE PROJECTION	DRAWN BY SKL IM01	DATE 2006/08/21	TITLE CUSTOM HEADER C-GRID, SINGLE WAFER HDR, THROU HOLE, VERTICAL, LF	CHECKED BY CWLAM	DATE 2006/09/04	APPROVED BY KWLEE	DATE 2006/09/04	MOLEX INCORPORATED	MATERIAL NO.	DOCUMENT NO. SD-87914-059	SHEET NO. 7 OF 9
			mm	INCH																													
		4 PLACES	± .005	± .0004																													
		3 PLACES	± .005	± .0004																													
2 PLACES	± 0.2	± .008																															
1 PLACE	± .005	± .0004																															
DRAFT WHERE APPLICABLE MUST REMAIN WITHIN DIMENSIONS	SEE TABLE	THIS DRAWING CONTAINS INFORMATION THAT IS PROPRIETARY TO MOLEX INCORPORATED AND SHOULD NOT BE USED WITHOUT WRITTEN PERMISSION																															
SIZE A3																																	



F	10		9		8		7		6		5		4		3		2		1	
	PART NO FOR TRAY PACKAGING	PART NO FOR BULK PACKAGING	CKT SIZE	PLATING TYPE	DIMENSION					PART NO FOR TRAY PACKAGING	PART NO FOR BULK PACKAGING	CKT SIZE	PLATING TYPE	DIMENSION						
					A	B	F	M	P					A	B	F	M	P		
	-----	87914-6201	62	1	78.74	76.20	13.21	8.13	2.79	-----	87914-6204	62	1	78.74	76.20	11.11	6.10	2.72		
	-----	87914-6202	62	2	78.74	76.20	13.21	8.13	2.79	-----	87914-6205	62	2	78.74	76.20	11.11	6.10	2.72		
	-----	87914-6203	62	3	78.74	76.20	13.21	8.13	2.79	-----	87914-6206	62	3	78.74	76.20	11.11	6.10	2.72		
	-----	87914-6401	64	1	81.28	78.74	13.21	8.13	2.79	-----	87914-6404	64	1	81.28	78.74	11.11	6.10	2.72		
	-----	87914-6402	64	2	81.28	78.74	13.21	8.13	2.79	-----	87914-6405	64	2	81.28	78.74	11.11	6.10	2.72		
	-----	87914-6403	64	3	81.28	78.74	13.21	8.13	2.79	-----	87914-6406	64	3	81.28	78.74	11.11	6.10	2.72		
	-----	87914-6601	66	1	83.82	81.28	13.21	8.13	2.79	-----	87914-6604	66	1	83.82	81.28	11.11	6.10	2.72		
	-----	87914-6602	66	2	83.82	81.28	13.21	8.13	2.79	-----	87914-6605	66	2	83.82	81.28	11.11	6.10	2.72		
	-----	87914-6603	66	3	83.82	81.28	13.21	8.13	2.79	-----	87914-6606	66	3	83.82	81.28	11.11	6.10	2.72		
	-----	87914-6801	68	1	86.36	83.82	13.21	8.13	2.79	-----	87914-6804	68	1	86.36	83.82	11.11	6.10	2.72		
	-----	87914-6802	68	2	86.36	83.82	13.21	8.13	2.79	-----	87914-6805	68	2	86.36	83.82	11.11	6.10	2.72		
	-----	87914-6803	68	3	86.36	83.82	13.21	8.13	2.79	-----	87914-6806	68	3	86.36	83.82	11.11	6.10	2.72		
	-----	87914-7001	70	1	88.90	86.36	13.21	8.13	2.79	-----	87914-7004	70	1	88.90	86.36	11.11	6.10	2.72		
	-----	87914-7002	70	2	88.90	86.36	13.21	8.13	2.79	-----	87914-7005	70	2	88.90	86.36	11.11	6.10	2.72		
	-----	87914-7003	70	3	88.90	86.36	13.21	8.13	2.79	-----	87914-7006	70	3	88.90	86.36	11.11	6.10	2.72		

--	--	--	--	--	--	--	--	--	--	--	--	--	--	--	--	--	--	--	--

<b>EWR# 1010 &amp; 1021</b> EC NO: S2007-0182 DRWNS:SKL IM01 2006/09/11 CHKD:CWLAM 2006/09/12 APPR:KWLEE 2006/09/13	QUALITY SYMBOLS =0 =0	GENERAL TOLERANCES (UNLESS SPECIFIED) <table border="1"> <tr> <th></th> <th>mm</th> <th>INCH</th> </tr> <tr> <td>4 PLACES</td> <td>± .005</td> <td>± .0002</td> </tr> <tr> <td>3 PLACES</td> <td>± .005</td> <td>± .0002</td> </tr> <tr> <td>2 PLACES</td> <td>± 0.2</td> <td>± .008</td> </tr> <tr> <td>1 PLACE</td> <td>± .005</td> <td>± .0002</td> </tr> </table>		mm	INCH	4 PLACES	± .005	± .0002	3 PLACES	± .005	± .0002	2 PLACES	± 0.2	± .008	1 PLACE	± .005	± .0002	DIMENSION STYLE <b>MM ONLY</b>	SCALE <b>NTS</b>	DESIGN UNITS <b>METRIC</b>	<b>THIRD ANGLE PROJECTION</b>
			mm	INCH																	
		4 PLACES	± .005	± .0002																	
		3 PLACES	± .005	± .0002																	
2 PLACES	± 0.2	± .008																			
1 PLACE	± .005	± .0002																			
DRAWN BY: SKL IM01 DATE: 2006/08/21 CHECKED BY: CWLAM DATE: 2006/09/04 APPROVED BY: KWLEE DATE: 2006/09/04		<b>CUSTOM HEADER</b> <b>C-GRID, SINGLE WAFER HDR, THROU HOLE, VERTICAL, LF</b>																			
MATERIAL NO.		DOCUMENT NO.		SHEET NO.																	
DRAFT WHERE APPLICABLE MUST REMAIN WITHIN DIMENSIONS		SEE TABLE		SD-87914-059																	

F	10		9		8		7		6		5		4		3		2		1	
	PART NO FOR TRAY PACKAGING	PART NO FOR BULK PACKAGING	CKT SIZE	PLATING TYPE	DIMENSION					PART NO FOR TRAY PACKAGING	PART NO FOR BULK PACKAGING	CKT SIZE	PLATING TYPE	DIMENSION						
					A	B	F	M	P					A	B	F	M	P		
	-----	87914-7201	72	1	91.44	88.90	13.21	8.13	2.79	-----	87914-7204	72	1	91.44	88.90	11.11	6.10	2.72		
	-----	87914-7202	72	2	91.44	88.90	13.21	8.13	2.79	-----	87914-7205	72	2	91.44	88.90	11.11	6.10	2.72		
	-----	87914-7203	72	3	91.44	88.90	13.21	8.13	2.79	-----	87914-7206	72	3	91.44	88.90	11.11	6.10	2.72		
	-----	87914-7401	74	1	93.98	91.44	13.21	8.13	2.79	-----	87914-7404	74	1	93.98	91.44	11.11	6.10	2.72		
	-----	87914-7402	74	2	93.98	91.44	13.21	8.13	2.79	-----	87914-7405	74	2	93.98	91.44	11.11	6.10	2.72		
	-----	87914-7403	74	3	93.98	91.44	13.21	8.13	2.79	-----	87914-7406	74	3	93.98	91.44	11.11	6.10	2.72		
	-----	87914-7601	76	1	96.52	93.98	13.21	8.13	2.79	-----	87914-7604	76	1	96.52	93.98	11.11	6.10	2.72		
	-----	87914-7602	76	2	96.52	93.98	13.21	8.13	2.79	-----	87914-7605	76	2	96.52	93.98	11.11	6.10	2.72		
	-----	87914-7603	76	3	96.52	93.98	13.21	8.13	2.79	-----	87914-7606	76	3	96.52	93.98	11.11	6.10	2.72		
	-----	87914-7801	78	1	99.06	96.52	13.21	8.13	2.79	-----	87914-7804	78	1	99.06	96.52	11.11	6.10	2.72		
	-----	87914-7802	78	2	99.06	96.52	13.21	8.13	2.79	-----	87914-7805	78	2	99.06	96.52	11.11	6.10	2.72		
	-----	87914-7803	78	3	99.06	96.52	13.21	8.13	2.79	-----	87914-7806	78	3	99.06	96.52	11.11	6.10	2.72		
	-----	87914-8001	80	1	101.60	99.06	13.21	8.13	2.79	-----	87914-8004	80	1	101.60	99.06	11.11	6.10	2.72		
	-----	87914-8002	80	2	101.60	99.06	13.21	8.13	2.79	-----	87914-8005	80	2	101.60	99.06	11.11	6.10	2.72		
	-----	87914-8003	80	3	101.60	99.06	13.21	8.13	2.79	-----	87914-8006	80	3	101.60	99.06	11.11	6.10	2.72		

B

A	EWR# 1010 & 1021 EC NO: S2007-0182 DRWNS:SKL IM01 2006/09/11 CHKD:CWLAM 2006/09/12 APPR:KWLEE 2006/09/13	QUALITY SYMBOLS =0 =0	GENERAL TOLERANCES (UNLESS SPECIFIED) <table border="1"> <tr> <th></th> <th>mm</th> <th>INCH</th> </tr> <tr> <td>4 PLACES</td> <td>± ---</td> <td>± ---</td> </tr> <tr> <td>3 PLACES</td> <td>± ---</td> <td>± ---</td> </tr> <tr> <td>2 PLACES</td> <td>± 0.2</td> <td>± ---</td> </tr> <tr> <td>1 PLACE</td> <td>± ---</td> <td>± ---</td> </tr> <tr> <td colspan="3">ANGULAR ± 3 °</td> </tr> </table>		mm	INCH	4 PLACES	± ---	± ---	3 PLACES	± ---	± ---	2 PLACES	± 0.2	± ---	1 PLACE	± ---	± ---	ANGULAR ± 3 °			DIMENSION STYLE <b>MM ONLY</b>	SCALE NTS	DESIGN UNITS METRIC	THIRD ANGLE PROJECTION
			mm	INCH																					
		4 PLACES	± ---	± ---																					
		3 PLACES	± ---	± ---																					
2 PLACES	± 0.2	± ---																							
1 PLACE	± ---	± ---																							
ANGULAR ± 3 °																									
DRAWN BY SKL IM01	DATE 2006/08/21	TITLE <b>CUSTOM HEADER          C-GRID, SINGLE WAFER HDR,          THROU HOLE, VERTICAL, LF</b>																							
CHECKED BY CWLAM	DATE 2006/09/04	MOLEX INCORPORATED																							
APPROVED BY KWLEE	DATE 2006/09/04	MATERIAL NO. <b>SEE TABLE</b>	DOCUMENT NO. <b>SD-87914-059</b>	SHEET NO. <b>9 OF 9</b>																					