



Chipsmall Limited consists of a professional team with an average of over 10 year of expertise in the distribution of electronic components. Based in Hongkong, we have already established firm and mutual-benefit business relationships with customers from,Europe,America and south Asia,supplying obsolete and hard-to-find components to meet their specific needs.

With the principle of “Quality Parts,Customers Priority,Honest Operation,and Considerate Service”,our business mainly focus on the distribution of electronic components. Line cards we deal with include Microchip,ALPS,ROHM,Xilinx,Pulse,ON,Everlight and Freescale. Main products comprise IC,Modules,Potentiometer,IC Socket,Relay,Connector.Our parts cover such applications as commercial,industrial, and automotives areas.

We are looking forward to setting up business relationship with you and hope to provide you with the best service and solution. Let us make a better world for our industry!



## Contact us

Tel: +86-755-8981 8866 Fax: +86-755-8427 6832

Email & Skype: info@chipsmall.com Web: www.chipsmall.com

Address: A1208, Overseas Decoration Building, #122 Zhenhua RD., Futian, Shenzhen, China



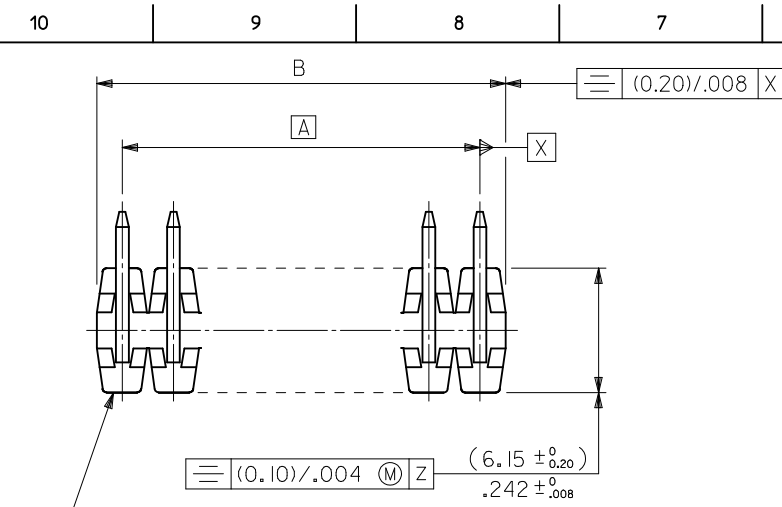

WAFER: 15% GLASS FILLED POLYESTER TO UL 94V-0. COLOUR: BLACK.

PINS: (0.650)/.0255 SQ. BRASS WIRE. PLATED AS PER SHEETS 2 TO 6.

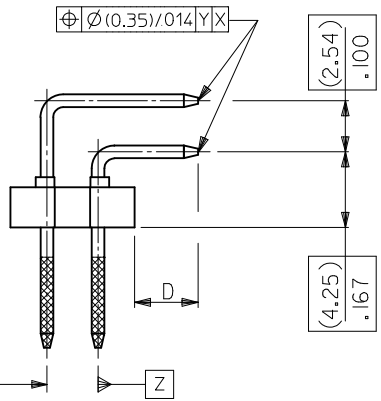
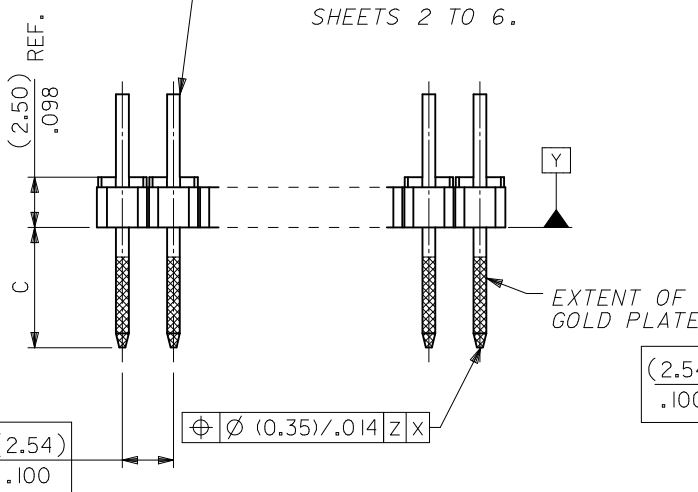

NOTES  
1. FOR ASSY NUMBERS WITH FINISH OPTIONS AND DIM'S C & D SEE SHEETS 2 TO 6.

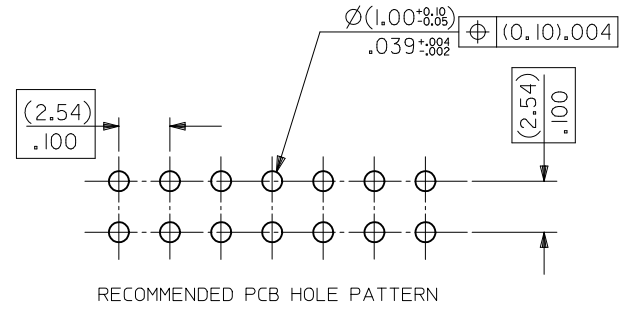

NOTES  
2. RECOMMENDED PCB THICKNESS: 1.6MM  
3. PRODUCT SPECIFICATION: PS-99020-0001

| CKT SIZE | DIM. "A" |       | DIM. "B" ( $\begin{smallmatrix} +0.20 \\ -0.35 \\ -0.008 \\ -0.014 \end{smallmatrix}$ ) |       | CKT SIZE | DIM. "A" |       | DIM. "B" ( $\begin{smallmatrix} \pm 0.20 \\ \pm .008 \end{smallmatrix}$ ) |       |
|----------|----------|-------|---|-------|----------|----------|-------|---|-------|
| 2X 1     |          |       | (2.54)  | .100  | 2X21     | (50.80)  | 2.000 | (53.34)   | 2.100 |
| 2X 2     | (2.54)   | .100  | (5.08)  | .200  | 2X22     | (53.34)  | 2.100 | (55.88)   | 2.200 |
| 2X 3     | (5.08)   | .200  | (7.62)  | .300  | 2X23     | (55.88)  | 2.200 | (58.42)   | 2.300 |
| 2X 4     | (7.62)   | .300  | (10.16)   | .400  | 2X24     | (58.42)  | 2.300 | (60.96)   | 2.400 |
| 2X 5     | (10.16)  | .400  | (12.70)   | .500  | 2X25     | (60.96)  | 2.400 | (63.50)   | 2.500 |
| 2X 6     | (12.70)  | .500  | (15.24)   | .600  | 2X26     | (63.50)  | 2.500 | (66.04)   | 2.600 |
| 2X 7     | (15.24)  | .600  | (17.78)   | .700  | 2X27     | (66.04)  | 2.600 | (68.58)   | 2.700 |
| 2X 8     | (17.78)  | .700  | (20.32)   | .800  | 2X28     | (68.58)  | 2.700 | (71.12)   | 2.800 |
| 2X 9     | (20.32)  | .800  | (22.86)   | .900  | 2X29     | (71.12)  | 2.800 | (73.66)   | 2.900 |
| 2X10     | (22.86)  | .900  | (25.40)   | 1.000 | 2X30     | (73.66)  | 2.900 | (76.20)   | 3.000 |
| 2X11     | (25.40)  | 1.000 | (27.94)   | 1.100 | 2X31     | (76.20)  | 3.000 | (78.74)   | 3.100 |
| 2X12     | (27.94)  | 1.100 | (30.48)   | 1.200 | 2X32     | (78.74)  | 3.100 | (81.28)   | 3.200 |
| 2X13     | (30.48)  | 1.200 | (33.02)   | 1.300 | 2X33     | (81.28)  | 3.200 | (83.82)   | 3.300 |
| 2X14     | (33.02)  | 1.300 | (35.56)   | 1.400 | 2X34     | (83.82)  | 3.300 | (86.36)   | 3.400 |
| 2X15     | (35.56)  | 1.400 | (38.10)   | 1.500 | 2X35     | (86.36)  | 3.400 | (88.90)   | 3.500 |
| 2X16     | (38.10)  | 1.500 | (40.64)   | 1.600 | 2X36     | (88.90)  | 3.500 | (91.44)   | 3.600 |
| 2X17     | (40.64)  | 1.600 | (43.18)   | 1.700 | 2X37     | (91.44)  | 3.600 | (93.98)   | 3.700 |
| 2X18     | (43.18)  | 1.700 | (45.72)   | 1.800 | 2X38     | (93.98)  | 3.700 | (96.52)   | 3.800 |
| 2X19     | (45.72)  | 1.800 | (48.26)   | 1.900 | 2X39     | (96.52)  | 3.800 | (99.06)   | 3.900 |
| 2X20     | (48.26)  | 1.900 | (50.80)   | 2.000 | 2X40     | (99.06)  | 3.900 | (101.60)  | 4.000 |

REVISE PIN DIM  
EC NO: S2012-0325  
DRWN:SKANG  
CHKD:ATSEE  
APPR:MLONG

QUALITY SYMBOLS  
F<sub>A</sub>=0  
F<sub>B</sub>=0  
F<sub>P</sub>=0

GENERAL TOLERANCES (UNLESS SPECIFIED)

|                | mm     | INCH   |
|----------------|--------|--------|
| 4 PLACES       | ± ---  | ± ---  |
| 3 PLACES       | ± ---  | ± ---  |
| 2 PLACES       | ± 0.05 | ± .002 |
| 1 PLACE        | ± ---  | ± ---  |
| ANGULAR ± ---° |        |        |

DRAFT WHERE APPLICABLE MUST REMAIN WITHIN DIMENSIONS

DIMENSION STYLE  
MM ONLY

DRAWN BY: DB  
DATE: 16/07/87

CHECKED BY: DB  
DATE: 1987/07/16

APPROVED BY: DB  
DATE: 1987/07/16

MATERIAL NO. SEE TABLE

SCALE: NTS  
DESIGN UNITS: METRIC  
THIRD ANGLE PROJECTION

C-GRID III  
DUAL ROW RIGHT  
ANGLE HEADER

MOLEX INCORPORATED  
SDA-90122

SHEET NO. 1 OF 6

THIS DRAWING CONTAINS INFORMATION THAT IS PROPRIETARY TO MOLEX INCORPORATED AND SHOULD NOT BE USED WITHOUT WRITTEN PERMISSION

10 9 8 7 6 5 4 3 2 1

| CIRCUIT SIZE | PLATING TYPE A | PLATING TYPE E | PLATING TYPE F |
|--------------|----------------|----------------|----------------|
|              | PART NO.       | PART NO.       | PART NO.       |
| 2 X 1        | 90122-0121     | 90122-0761     | 90122-0921     |
| 2 X 2        | ▲ -0122        | ▲ -0762        | ▲ -0922        |
| 2 X 3        | -0123          | -0763          | -0923          |
| 2 X 4        | -0124          | -0764          | -0924          |
| 2 X 5        | -0125          | -0765          | -0925          |
| 2 X 6        | -0126          | -0766          | -0926          |
| 2 X 7        | -0127          | -0767          | -0927          |
| 2 X 8        | -0128          | -0768          | -0928          |
| 2 X 9        | -0129          | -0769          | -0929          |
| 2 X 10       | -0130          | -0770          | -0930          |
| 2 X 11       | -0131          | -0771          | -0931          |
| 2 X 12       | -0132          | -0772          | -0932          |
| 2 X 13       | -0133          | -0773          | -0933          |
| 2 X 14       | -0134          | -0774          | -0934          |
| 2 X 15       | -0135          | -0775          | -0935          |
| 2 X 16       | -0136          | -0776          | -0936          |
| 2 X 17       | -0137          | -0777          | -0937          |
| 2 X 18       | -0138          | -0778          | -0938          |
| 2 X 19       | -0139          | -0779          | -0939          |
| 2 X 20       | -0140          | -0780          | -0940          |
| 2 X 21       | -0141          | -0781          | -0941          |
| 2 X 22       | -0142          | -0782          | -0942          |
| 2 X 23       | -0143          | -0783          | -0943          |
| 2 X 24       | -0144          | -0784          | -0944          |
| 2 X 25       | -0145          | -0785          | -0945          |
| 2 X 26       | -0146          | -0786          | -0946          |
| 2 X 27       | -0147          | -0787          | -0947          |
| 2 X 28       | -0148          | -0788          | -0948          |
| 2 X 29       | -0149          | -0789          | -0949          |
| 2 X 30       | -0150          | -0790          | -0950          |
| 2 X 31       | -0151          | -0791          | -0951          |
| 2 X 32       | -0152          | -0792          | -0952          |
| 2 X 33       | -0153          | -0793          | -0953          |
| 2 X 34       | -0154          | -0794          | -0954          |
| 2 X 35       | -0155          | -0795          | -0955          |
| 2 X 36       | -0156          | -0796          | -0956          |
| 2 X 37       | -0157          | -0797          | -0957          |
| 2 X 38       | -0158          | -0798          | -0958          |
| 2 X 39       | ▼ -0159        | ▼ -0799        | ▼ -0959        |
| 2 X 40       | 90122-0160     | 90122-0800     | 90122-0960     |

DIM C (±0.20) ±.008 (6.75) .266

DIM D (±0.25) ±.010 (2.90) .114

NOTES:  
FOR PLATING VARIATIONS SEE  
ENG.STD. SDES-99000-0003.

|   |  |                                       |   |  |              |                        |
|---|--|---------------------------------------|---|--|--------------|------------------------|
| REVISE PIN DIM<br>EC NO: S2012-0325<br>DRWN:SKANG<br>CHKD:ATSEE<br>APPR:MLONG<br>2011/10/21<br>2011/10/31<br>2011/10/31 | QUALITY SYMBOLS                                    | GENERAL TOLERANCES (UNLESS SPECIFIED) | DIMENSION STYLE   | SCALE  | DESIGN UNITS | THIRD ANGLE PROJECTION |
|   | $\nabla_A = 0$<br>$\nabla_E = 0$<br>$\nabla_F = 0$ | mm INCH                               | MM ONLY   | NTS  | METRIC       |                        |
|   |  | 4 PLACES ± --- ± ---                  | DRAWN BY DATE   | TITLE  |              |                        |
|   |  | 3 PLACES ± --- ± ---                  | DB 16/07/87   | C-GRID III<br>DUAL ROW RIGHT<br>ANGLE HEADER |              |                        |
|   | 2 PLACES ± 0.05 ± .002                             | CHECKED BY DATE                       | MOLEX INCORPORATED  |  |              |                        |
|   | 1 PLACE ± --- ± ---                                | DB 1987/07/16                         | DOCUMENT NO. SDA-90122  |  |              |                        |
|   | ANGULAR ± ---°                                     | APPROVED BY DATE                      | SHEET NO. 2 OF 6  |  |              |                        |
|   |  | DB 1987/07/16                         | THIS DRAWING CONTAINS INFORMATION THAT IS PROPRIETARY TO MOLEX INCORPORATED AND SHOULD NOT BE USED WITHOUT WRITTEN PERMISSION |  |              |                        |
|   |  | MATERIAL NO.                          |   |  |              |                        |
|   |  | SEE TABLE                             |   |  |              |                        |
|   |  | SIZE A3                               |   |  |              |                        |
|   |  |                                       |   |  |              |                        |

9 8 7 6 5 4 3 2 1

|   | 10 | 9            | 8                       | 7                       | 6                       | 5 | 4            | 3                       | 2                       | 1                       |   |
|---|----|--------------|-------------------------|-------------------------|-------------------------|---|--------------|-------------------------|-------------------------|-------------------------|---|
| F |    | CIRCUIT SIZE | PLATING TYPE A PART NO. | PLATING TYPE E PART NO. | PLATING TYPE F PART NO. |   | CIRCUIT SIZE | PLATING TYPE A PART NO. | PLATING TYPE E PART NO. | PLATING TYPE F PART NO. | F |
|   |    | 2 X 1        | 90122-0041              | 90122-0681              | 90122-0841              |   | 2 X 1        | 90122-0081              | 90122-0721              | 90122-0881              |   |
|   |    | 2 X 2        | ▲ -0042                 | ▲ -0682                 | ▲ -0842                 |   | 2 X 2        | ▲ -0082                 | ▲ -0722                 | ▲ -0882                 |   |
|   |    | 2 X 3        | -0043                   | -0683                   | -0843                   |   | 2 X 3        | -0083                   | -0723                   | -0883                   |   |
|   |    | 2 X 4        | -0044                   | -0684                   | -0844                   |   | 2 X 4        | -0084                   | -0724                   | -0884                   |   |
|   |    | 2 X 5        | -0045                   | -0685                   | -0845                   |   | 2 X 5        | -0085                   | -0725                   | -0885                   |   |
|   |    | 2 X 6        | -0046                   | -0686                   | -0846                   |   | 2 X 6        | -0086                   | -0726                   | -0886                   |   |
|   |    | 2 X 7        | -0047                   | -0687                   | -0847                   |   | 2 X 7        | -0087                   | -0727                   | -0887                   |   |
|   |    | 2 X 8        | -0048                   | -0688                   | -0848                   |   | 2 X 8        | -0088                   | -0728                   | -0888                   |   |
|   |    | 2 X 9        | -0049                   | -0689                   | -0849                   |   | 2 X 9        | -0089                   | -0729                   | -0889                   |   |
| E |    | 2 X 10       | -0050                   | -0690                   | -0850                   |   | 2 X 10       | -0090                   | -0730                   | -0890                   | E |
|   |    | 2 X 11       | -0051                   | -0691                   | -0851                   |   | 2 X 11       | -0091                   | -0731                   | -0891                   |   |
|   |    | 2 X 12       | -0052                   | -0692                   | -0852                   |   | 2 X 12       | -0092                   | -0732                   | -0892                   |   |
|   |    | 2 X 13       | -0053                   | -0693                   | -0853                   |   | 2 X 13       | -0093                   | -0733                   | -0893                   |   |
|   |    | 2 X 14       | -0054                   | -0694                   | -0854                   |   | 2 X 14       | -0094                   | -0734                   | -0894                   |   |
|   |    | 2 X 15       | -0055                   | -0695                   | -0855                   |   | 2 X 15       | -0095                   | -0735                   | -0895                   |   |
|   |    | 2 X 16       | -0056                   | -0696                   | -0856                   |   | 2 X 16       | -0096                   | -0736                   | -0896                   |   |
|   |    | 2 X 17       | -0057                   | -0697                   | -0857                   |   | 2 X 17       | -0097                   | -0737                   | -0897                   |   |
|   |    | 2 X 18       | -0058                   | -0698                   | -0858                   |   | 2 X 18       | -0098                   | -0738                   | -0898                   |   |
|   |    | 2 X 19       | -0059                   | -0699                   | -0859                   |   | 2 X 19       | -0099                   | -0739                   | -0899                   |   |
| D |    | 2 X 20       | -0060                   | -0700                   | -0860                   |   | 2 X 20       | -0100                   | -0740                   | -0900                   | D |
|   |    | 2 X 21       | -0061                   | -0701                   | -0861                   |   | 2 X 21       | -0101                   | -0741                   | -0901                   |   |
|   |    | 2 X 22       | -0062                   | -0702                   | -0862                   |   | 2 X 22       | -0102                   | -0742                   | -0902                   |   |
|   |    | 2 X 23       | -0063                   | -0703                   | -0863                   |   | 2 X 23       | -0103                   | -0743                   | -0903                   |   |
|   |    | 2 X 24       | -0064                   | -0704                   | -0864                   |   | 2 X 24       | -0104                   | -0744                   | -0904                   |   |
|   |    | 2 X 25       | -0065                   | -0705                   | -0865                   |   | 2 X 25       | -0105                   | -0745                   | -0905                   |   |
|   |    | 2 X 26       | -0066                   | -0706                   | -0866                   |   | 2 X 26       | -0106                   | -0746                   | -0906                   |   |
|   |    | 2 X 27       | -0067                   | -0707                   | -0867                   |   | 2 X 27       | -0107                   | -0747                   | -0907                   |   |
|   |    | 2 X 28       | -0068                   | -0708                   | -0868                   |   | 2 X 28       | -0108                   | -0748                   | -0908                   |   |
|   |    | 2 X 29       | -0069                   | -0709                   | -0869                   |   | 2 X 29       | -0109                   | -0749                   | -0909                   |   |
| C |    | 2 X 30       | -0070                   | -0710                   | -0870                   |   | 2 X 30       | -0110                   | -0750                   | -0910                   | C |
|   |    | 2 X 31       | -0071                   | -0711                   | -0871                   |   | 2 X 31       | -0111                   | -0751                   | -0911                   |   |
|   |    | 2 X 32       | -0072                   | -0712                   | -0872                   |   | 2 X 32       | -0112                   | -0752                   | -0912                   |   |
|   |    | 2 X 33       | -0073                   | -0713                   | -0873                   |   | 2 X 33       | -0113                   | -0753                   | -0913                   |   |
|   |    | 2 X 34       | -0074                   | -0714                   | -0874                   |   | 2 X 34       | -0114                   | -0754                   | -0914                   |   |
|   |    | 2 X 35       | -0075                   | -0715                   | -0875                   |   | 2 X 35       | -0115                   | -0755                   | -0915                   |   |
|   |    | 2 X 36       | -0076                   | -0716                   | -0876                   |   | 2 X 36       | -0116                   | -0756                   | -0916                   |   |
|   |    | 2 X 37       | -0077                   | -0717                   | -0877                   |   | 2 X 37       | -0117                   | -0757                   | -0917                   |   |
|   |    | 2 X 38       | -0078                   | -0718                   | -0878                   |   | 2 X 38       | -0118                   | -0758                   | -0918                   |   |
| B |    | 2 X 39       | ▼ -0079                 | ▼ -0719                 | ▼ -0879                 |   | 2 X 39       | ▼ -0119                 | ▼ -0759                 | ▼ -0919                 | B |
|   |    | 2 X 40       | 90122-0080              | 90122-0720              | 90122-0880              |   | 2 X 40       | 90122-0120              | 90122-0760              | 90122-0920              |   |

DIM C (±0.20) ±.008 (5.75) .226

DIM D (±0.25) ±.010 (2.90) .114

DIM C (±0.20) ±.008 (5.75) .226

DIM D (±0.25) ±.010 (4.50) .177

NOTES:  
FOR PLATING VARIATIONS SEE  
ENG.STD. SDES-99000-0003.

| REVISE PIN DIM<br>EC NO: S2012-0325<br>DRWN:SKANG<br>CHKD:ATSEE<br>APPR:MLONG<br>2011/10/21<br>2011/10/31<br>2011/10/31 | QUALITY SYMBOLS   | GENERAL TOLERANCES (UNLESS SPECIFIED)   | DIMENSION STYLE | SCALE  | DESIGN UNITS | THIRD ANGLE PROJECTION |  |            |          |             |       |          |            |  |              |              |           |           |           |        |  |
|---|---|---|-----------------|--|--------------|------------------------|--|------------|----------|-------------|-------|----------|------------|--|--------------|--------------|-----------|-----------|-----------|--------|--|
|   | $\nabla_A = 0$<br>$\nabla_C = 0$<br>$\nabla_P = 0$  | <table border="1"> <tr> <th></th> <th>mm</th> <th>INCH</th> </tr> <tr> <td>4 PLACES</td> <td>± ---</td> <td>± ---</td> </tr> <tr> <td>3 PLACES</td> <td>± ---</td> <td>± ---</td> </tr> <tr> <td>2 PLACES</td> <td>± 0.05</td> <td>± .002</td> </tr> <tr> <td>1 PLACE</td> <td>± ---</td> <td>± ---</td> </tr> </table> |                 | mm   | INCH         | 4 PLACES               | ± ---  | ± ---      | 3 PLACES | ± ---       | ± --- | 2 PLACES | ± 0.05     | ± .002   | 1 PLACE      | ± ---        | ± ---     | MM ONLY   | NTS       | METRIC |  |
|   |   | mm  | INCH            |  |              |                        |  |            |          |             |       |          |            |  |              |              |           |           |           |        |  |
|   | 4 PLACES  | ± ---   | ± ---           |  |              |                        |  |            |          |             |       |          |            |  |              |              |           |           |           |        |  |
| 3 PLACES  | ± ---   | ± ---   |                 |  |              |                        |  |            |          |             |       |          |            |  |              |              |           |           |           |        |  |
| 2 PLACES  | ± 0.05  | ± .002  |                 |  |              |                        |  |            |          |             |       |          |            |  |              |              |           |           |           |        |  |
| 1 PLACE   | ± ---   | ± ---   |                 |  |              |                        |  |            |          |             |       |          |            |  |              |              |           |           |           |        |  |
| DESCRIPTION   | <table border="1"> <tr> <td>DRAWN BY</td> <td>DATE</td> <td>TITLE</td> </tr> <tr> <td>DB</td> <td>16/07/87</td> <td rowspan="4">           C-GRID III<br/>           DUAL ROW RIGHT<br/>           ANGLE HEADER<br/> <br/>            MOLEX INCORPORATED         </td> </tr> <tr> <td>CHECKED BY</td> <td>DATE</td> </tr> <tr> <td>APPROVED BY</td> <td>DATE</td> </tr> <tr> <td>DB</td> <td>1987/07/16</td> </tr> </table> | DRAWN BY  | DATE            | TITLE  | DB           | 16/07/87               | C-GRID III<br>DUAL ROW RIGHT<br>ANGLE HEADER<br><br>MOLEX INCORPORATED | CHECKED BY | DATE     | APPROVED BY | DATE  | DB       | 1987/07/16 | <table border="1"> <tr> <td>MATERIAL NO.</td> <td>DOCUMENT NO.</td> <td>SHEET NO.</td> </tr> <tr> <td>SEE TABLE</td> <td>SDA-90122</td> <td>3 OF 6</td> </tr> </table> | MATERIAL NO. | DOCUMENT NO. | SHEET NO. | SEE TABLE | SDA-90122 | 3 OF 6 |  |
| DRAWN BY  | DATE  | TITLE   |                 |  |              |                        |  |            |          |             |       |          |            |  |              |              |           |           |           |        |  |
| DB  | 16/07/87  | C-GRID III<br>DUAL ROW RIGHT<br>ANGLE HEADER<br><br>MOLEX INCORPORATED  |                 |  |              |                        |  |            |          |             |       |          |            |  |              |              |           |           |           |        |  |
| CHECKED BY  | DATE  |   |                 |  |              |                        |  |            |          |             |       |          |            |  |              |              |           |           |           |        |  |
| APPROVED BY   | DATE  |   |                 |  |              |                        |  |            |          |             |       |          |            |  |              |              |           |           |           |        |  |
| DB  | 1987/07/16  |   |                 |  |              |                        |  |            |          |             |       |          |            |  |              |              |           |           |           |        |  |
| MATERIAL NO.  | DOCUMENT NO.  | SHEET NO.   |                 |  |              |                        |  |            |          |             |       |          |            |  |              |              |           |           |           |        |  |
| SEE TABLE   | SDA-90122   | 3 OF 6  |                 |  |              |                        |  |            |          |             |       |          |            |  |              |              |           |           |           |        |  |
| REV   | DRAFT WHERE APPLICABLE<br>MUST REMAIN<br>WITHIN DIMENSIONS  | <table border="1"> <tr> <td>SIZE</td> <td>THIS DRAWING CONTAINS INFORMATION THAT IS PROPRIETARY TO MOLEX<br/>INCORPORATED AND SHOULD NOT BE USED WITHOUT WRITTEN PERMISSION</td> </tr> <tr> <td>A3</td> <td></td> </tr> </table>  | SIZE            | THIS DRAWING CONTAINS INFORMATION THAT IS PROPRIETARY TO MOLEX<br>INCORPORATED AND SHOULD NOT BE USED WITHOUT WRITTEN PERMISSION | A3           |                        |  |            |          |             |       |          |            |  |              |              |           |           |           |        |  |
| SIZE  | THIS DRAWING CONTAINS INFORMATION THAT IS PROPRIETARY TO MOLEX<br>INCORPORATED AND SHOULD NOT BE USED WITHOUT WRITTEN PERMISSION  |   |                 |  |              |                        |  |            |          |             |       |          |            |  |              |              |           |           |           |        |  |
| A3  |   |   |                 |  |              |                        |  |            |          |             |       |          |            |  |              |              |           |           |           |        |  |

10 9 8 7 6 5 4 3 2 1

| CIRCUIT SIZE | PLATING TYPE A PART NO. | PLATING TYPE E PART NO. | PLATING TYPE F PART NO. |
|--------------|-------------------------|-------------------------|-------------------------|
| 2 X 1        | 90122-0161              | 90122-0801              | 90122-0961              |
| 2 X 2        | ▲ -0162                 | ▲ -0802                 | ▲ -0962                 |
| 2 X 3        | -0163                   | -0803                   | -0963                   |
| 2 X 4        | -0164                   | -0804                   | -0964                   |
| 2 X 5        | -0165                   | -0805                   | -0965                   |
| 2 X 6        | -0166                   | -0806                   | -0966                   |
| 2 X 7        | -0167                   | -0807                   | -0967                   |
| 2 X 8        | -0168                   | -0808                   | -0968                   |
| 2 X 9        | -0169                   | -0809                   | -0969                   |
| 2 X 10       | -0170                   | -0810                   | -0970                   |
| 2 X 11       | -0171                   | -0811                   | -0971                   |
| 2 X 12       | -0172                   | -0812                   | -0972                   |
| 2 X 13       | -0173                   | -0813                   | -0973                   |
| 2 X 14       | -0174                   | -0814                   | -0974                   |
| 2 X 15       | -0175                   | -0815                   | -0975                   |
| 2 X 16       | -0176                   | -0816                   | -0976                   |
| 2 X 17       | -0177                   | -0817                   | -0977                   |
| 2 X 18       | -0178                   | -0818                   | -0978                   |
| 2 X 19       | -0179                   | -0819                   | -0979                   |
| 2 X 20       | -0180                   | -0820                   | -0980                   |
| 2 X 21       | -0181                   | -0821                   | -0981                   |
| 2 X 22       | -0182                   | -0822                   | -0982                   |
| 2 X 23       | -0183                   | -0823                   | -0983                   |
| 2 X 24       | -0184                   | -0824                   | -0984                   |
| 2 X 25       | -0185                   | -0825                   | -0985                   |
| 2 X 26       | -0186                   | -0826                   | -0986                   |
| 2 X 27       | -0187                   | -0827                   | -0987                   |
| 2 X 28       | -0188                   | -0828                   | -0988                   |
| 2 X 29       | -0189                   | -0829                   | -0989                   |
| 2 X 30       | -0190                   | -0830                   | -0990                   |
| 2 X 31       | -0191                   | -0831                   | -0991                   |
| 2 X 32       | -0192                   | -0832                   | -0992                   |
| 2 X 33       | -0193                   | -0833                   | -0993                   |
| 2 X 34       | -0194                   | -0834                   | -0994                   |
| 2 X 35       | -0195                   | -0835                   | -0995                   |
| 2 X 36       | -0196                   | -0836                   | -0996                   |
| 2 X 37       | -0197                   | -0837                   | -0997                   |
| 2 X 38       | -0198                   | -0838                   | -0998                   |
| 2 X 39       | ▼ -0199                 | ▼ -0839                 | ▼ -0999                 |
| 2 X 40       | 90122-0200              | 90122-0840              | 90122-1000              |

DIM C  
(±0.20)  
(6.75)  
±.008  
.266

DIM D  
(±0.25)  
(4.50)  
±.010  
.177

NOTES:  
FOR PLATING VARIATIONS SEE  
ENG.STD. SDES-99000-0003.

|   |  |  |   |  |              |                        |
|---|--|--|---|--|--------------|------------------------|
| REVISE PIN DIM<br>EC NO: S2012-0325<br>DRWN:SKANG<br>CHKD:ATSEE<br>APPR:MLONG<br>2011/10/21<br>2011/10/31<br>2011/10/31 | QUALITY SYMBOLS                              | GENERAL TOLERANCES (UNLESS SPECIFIED)                | DIMENSION STYLE   | SCALE  | DESIGN UNITS | THIRD ANGLE PROJECTION |
|   | $\nabla_A=0$<br>$\nabla_C=0$<br>$\nabla_P=0$ | mm INCH  | MM ONLY   | NTS  | METRIC       |                        |
|   |  | 4 PLACES ± --- ± ---                                 | DRAWN BY DATE   | TITLE  |              |                        |
|   |  | 3 PLACES ± --- ± ---                                 | DB 16/07/87   | C-GRID III<br>DUAL ROW RIGHT<br>ANGLE HEADER |              |                        |
|   | 2 PLACES ± 0.05 ± .002                       | CHECKED BY DATE                                      | MOLEX INCORPORATED  |  |              |                        |
|   | 1 PLACE ± --- ± ---                          | DB 1987/07/16  | DOCUMENT NO.  |  |              |                        |
|   | ANGULAR ± ---°                               | APPROVED BY DATE                                     | SDA-90122   |  |              |                        |
|   |  | DB 1987/07/16  | SHEET NO.   |  |              |                        |
|   |  | MATERIAL NO.   | 4 OF 6  |  |              |                        |
|   |  | SEE TABLE  | THIS DRAWING CONTAINS INFORMATION THAT IS PROPRIETARY TO MOLEX INCORPORATED AND SHOULD NOT BE USED WITHOUT WRITTEN PERMISSION |  |              |                        |
|   |  | DRAFT WHERE APPLICABLE MUST REMAIN WITHIN DIMENSIONS |   |  |              |                        |

9 8 7 6 5 4 3 2 1



|   | 10 | 9            | 8                       | 7                       | 6                       | 5                       | 4 | 3            | 2                       | 1                       |                         |                         |   |
|---|----|--------------|-------------------------|-------------------------|-------------------------|-------------------------|---|--------------|-------------------------|-------------------------|-------------------------|-------------------------|---|
| F |    | CIRCUIT SIZE | PLATING TYPE B PART NO. | PLATING TYPE C PART NO. | PLATING TYPE D PART NO. | PLATING TYPE G PART NO. |   | CIRCUIT SIZE | PLATING TYPE B PART NO. | PLATING TYPE C PART NO. | PLATING TYPE D PART NO. | PLATING TYPE G PART NO. | F |
|   |    | 2 X 1        | 90122-0281              | 90122-0441              | 90122-0601              | 90122-1081              |   | 2 X 1        | 90122-0201              | 90122-0361              | 90122-0521              | 90122-1001              |   |
|   |    | 2 X 2        | ▲ -0282                 | ▲ -0442                 | ▲ -0602                 | ▲ -1082                 |   | 2 X 2        | ▲ -0202                 | ▲ -0362                 | ▲ -0522                 | ▲ -1002                 |   |
|   |    | 2 X 3        | -0283                   | -0443                   | -0603                   | -1083                   |   | 2 X 3        | -0203                   | -0363                   | -0523                   | -1003                   |   |
|   |    | 2 X 4        | -0284                   | -0444                   | -0604                   | -1084                   |   | 2 X 4        | -0204                   | -0364                   | -0524                   | -1004                   |   |
|   |    | 2 X 5        | -0285                   | -0445                   | -0605                   | -1085                   |   | 2 X 5        | -0205                   | -0365                   | -0525                   | -1005                   |   |
|   |    | 2 X 6        | -0286                   | -0446                   | -0606                   | -1086                   |   | 2 X 6        | -0206                   | -0366                   | -0526                   | -1006                   |   |
|   |    | 2 X 7        | -0287                   | -0447                   | -0607                   | -1087                   |   | 2 X 7        | -0207                   | -0367                   | -0527                   | -1007                   |   |
|   |    | 2 X 8        | -0288                   | -0448                   | -0608                   | -1088                   |   | 2 X 8        | -0208                   | -0368                   | -0528                   | -1008                   |   |
|   |    | 2 X 9        | -0289                   | -0449                   | -0609                   | -1089                   |   | 2 X 9        | -0209                   | -0369                   | -0529                   | -1009                   |   |
|   |    | 2 X 10       | -0290                   | -0450                   | -0610                   | -1090                   |   | 2 X 10       | -0210                   | -0370                   | -0530                   | -1010                   |   |
|   |    | 2 X 11       | -0291                   | -0451                   | -0611                   | -1091                   |   | 2 X 11       | -0211                   | -0371                   | -0531                   | -1011                   |   |
|   |    | 2 X 12       | -0292                   | -0452                   | -0612                   | -1092                   |   | 2 X 12       | -0212                   | -0372                   | -0532                   | -1012                   |   |
|   |    | 2 X 13       | -0293                   | -0453                   | -0613                   | -1093                   |   | 2 X 13       | -0213                   | -0373                   | -0533                   | -1013                   |   |
|   |    | 2 X 14       | -0294                   | -0454                   | -0614                   | -1094                   |   | 2 X 14       | -0214                   | -0374                   | -0534                   | -1014                   |   |
|   |    | 2 X 15       | -0295                   | -0455                   | -0615                   | -1095                   |   | 2 X 15       | -0215                   | -0375                   | -0535                   | -1015                   |   |
|   |    | 2 X 16       | -0296                   | -0456                   | -0616                   | -1096                   |   | 2 X 16       | -0216                   | -0376                   | -0536                   | -1016                   |   |
|   |    | 2 X 17       | -0297                   | -0457                   | -0617                   | -1097                   |   | 2 X 17       | -0217                   | -0377                   | -0537                   | -1017                   |   |
|   |    | 2 X 18       | -0298                   | -0458                   | -0618                   | -1098                   |   | 2 X 18       | -0218                   | -0378                   | -0538                   | -1018                   |   |
|   |    | 2 X 19       | -0299                   | -0459                   | -0619                   | -1099                   |   | 2 X 19       | -0219                   | -0379                   | -0539                   | -1019                   |   |
|   |    | 2 X 20       | -0300                   | -0460                   | -0620                   | -1100                   |   | 2 X 20       | -0220                   | -0380                   | -0540                   | -1020                   |   |
|   |    | 2 X 21       | -0301                   | -0461                   | -0621                   | -1101                   |   | 2 X 21       | -0221                   | -0381                   | -0541                   | -1021                   |   |
|   |    | 2 X 22       | -0302                   | -0462                   | -0622                   | -1102                   |   | 2 X 22       | -0222                   | -0382                   | -0542                   | -1022                   |   |
|   |    | 2 X 23       | -0303                   | -0463                   | -0623                   | -1103                   |   | 2 X 23       | -0223                   | -0383                   | -0543                   | -1023                   |   |
|   |    | 2 X 24       | -0304                   | -0464                   | -0624                   | -1104                   |   | 2 X 24       | -0224                   | -0384                   | -0544                   | -1024                   |   |
|   |    | 2 X 25       | -0305                   | -0465                   | -0625                   | -1105                   |   | 2 X 25       | -0225                   | -0385                   | -0545                   | -1025                   |   |
|   |    | 2 X 26       | -0306                   | -0466                   | -0626                   | -1106                   |   | 2 X 26       | -0226                   | -0386                   | -0546                   | -1026                   |   |
|   |    | 2 X 27       | -0307                   | -0467                   | -0627                   | -1107                   |   | 2 X 27       | -0227                   | -0387                   | -0547                   | -1027                   |   |
|   |    | 2 X 28       | -0308                   | -0468                   | -0628                   | -1108                   |   | 2 X 28       | -0228                   | -0388                   | -0548                   | -1028                   |   |
|   |    | 2 X 29       | -0309                   | -0469                   | -0629                   | -1109                   |   | 2 X 29       | -0229                   | -0389                   | -0549                   | -1029                   |   |
|   |    | 2 X 30       | -0310                   | -0470                   | -0630                   | -1110                   |   | 2 X 30       | -0230                   | -0390                   | -0550                   | -1030                   |   |
|   |    | 2 X 31       | -0311                   | -0471                   | -0631                   | -1111                   |   | 2 X 31       | -0231                   | -0391                   | -0551                   | -1031                   |   |
|   |    | 2 X 32       | -0312                   | -0472                   | -0632                   | -1112                   |   | 2 X 32       | -0232                   | -0392                   | -0552                   | -1032                   |   |
|   |    | 2 X 33       | -0313                   | -0473                   | -0633                   | -1113                   |   | 2 X 33       | -0233                   | -0393                   | -0553                   | -1033                   |   |
|   |    | 2 X 34       | -0314                   | -0474                   | -0634                   | -1114                   |   | 2 X 34       | -0234                   | -0394                   | -0554                   | -1034                   |   |
|   |    | 2 X 35       | -0315                   | -0475                   | -0635                   | -1115                   |   | 2 X 35       | -0235                   | -0395                   | -0555                   | -1035                   |   |
|   |    | 2 X 36       | -0316                   | -0476                   | -0636                   | -1116                   |   | 2 X 36       | -0236                   | -0396                   | -0556                   | -1036                   |   |
|   |    | 2 X 37       | -0317                   | -0477                   | -0637                   | -1117                   |   | 2 X 37       | -0237                   | -0397                   | -0557                   | -1037                   |   |
|   |    | 2 X 38       | -0318                   | -0478                   | -0638                   | -1118                   |   | 2 X 38       | -0238                   | -0398                   | -0558                   | -1038                   |   |
|   |    | 2 X 39       | ▼ -0319                 | ▼ -0479                 | ▼ -0639                 | ▼ -1119                 |   | 2 X 39       | ▼ -0239                 | ▼ -0399                 | ▼ -0559                 | ▼ -1039                 |   |
|   |    | 2 X 40       | 90122-0320              | 90122-0480              | 90122-0640              | 90122-1120              |   | 2 X 40       | 90122-0240              | 90122-0400              | 90122-0560              | 90122-1040              |   |

DIM C (±0.20) ±.008 (6.75) .266

DIM C (±0.20) ±.008 (5.75) .226

DIM D (±0.25) ±.010 (2.90) .114

DIM D (±0.25) ±.010 (2.90) .114

NOTES:  
FOR PLATING VARIATIONS SEE  
ENG.STD. SDES-99000-0003.

|                   |             |  |
|-------------------|-------------|--|
| REVISE PIN DIM    | 2011/10/21  |  |
| EC NO: S2012-0325 | 2011/10/31  |  |
| DRWN:SKANG        | 2011/10/31  |  |
| CHKD:ATSEE        | 2011/10/31  |  |
| APPR:MLONG        | 2011/10/31  |  |
| REV               | DESCRIPTION |  |
| M2                |             |  |

|                 |         |
|-----------------|---------|
| QUALITY SYMBOLS | $F_A=0$ |
|                 | $F_C=0$ |
|                 | $F_B=0$ |

|  |       |       |
|--|-------|-------|
| GENERAL TOLERANCES (UNLESS SPECIFIED)                | mm    | INCH  |
| 4 PLACES   | ±---  | ±---  |
| 3 PLACES   | ±---  | ±---  |
| 2 PLACES   | ±0.05 | ±.002 |
| 1 PLACE  | ±---  | ±---  |
| ANGULAR ±---°  |       |       |
| DRAFT WHERE APPLICABLE MUST REMAIN WITHIN DIMENSIONS |       |       |

|                 |            |  |              |                        |
|-----------------|------------|--|--------------|------------------------|
| DIMENSION STYLE |            | SCALE  | DESIGN UNITS | THIRD ANGLE PROJECTION |
| MM ONLY         |            | NTS  | METRIC       |                        |
| DRAWN BY        | DATE       | TITLE  |              |                        |
| DB              | 16/07/87   | C-GRID III<br>DUAL ROW RIGHT<br>ANGLE HEADER |              |                        |
| CHECKED BY      | DATE       |  |              |                        |
| DB              | 1987/07/16 | MOLEX INCORPORATED                           |              |                        |
| APPROVED BY     | DATE       |  |              |                        |
| DB              | 1987/07/16 | MATERIAL NO.                                 | DOCUMENT NO. | SHEET NO.              |
| SEE TABLE       |            | SDA-90122                                    |              | 5 OF 6                 |

|   |  |  |  |  |
|---|--|--|--|--|
| THIS DRAWING CONTAINS INFORMATION THAT IS PROPRIETARY TO MOLEX INCORPORATED AND SHOULD NOT BE USED WITHOUT WRITTEN PERMISSION |  |  |  |  |
|---|--|--|--|--|

|   | 10 | 9            | 8                       | 7                       | 6                       | 5                       | 4 | 3            | 2                       | 1                       |                         |                         |   |
|---|----|--------------|-------------------------|-------------------------|-------------------------|-------------------------|---|--------------|-------------------------|-------------------------|-------------------------|-------------------------|---|
| F |    | CIRCUIT SIZE | PLATING TYPE B PART NO. | PLATING TYPE C PART NO. | PLATING TYPE D PART NO. | PLATING TYPE G PART NO. |   | CIRCUIT SIZE | PLATING TYPE B PART NO. | PLATING TYPE C PART NO. | PLATING TYPE D PART NO. | PLATING TYPE G PART NO. | F |
|   |    | 2 X 1        | 90122-0241              | 90122-0401              | 90122-0561              | 90122-1041              |   | 2 X 1        | 90122-0321              | 90122-0481              | 90122-0641              | 90122-1121              |   |
|   |    | 2 X 2        | ▲ -0242                 | ▲ -0402                 | ▲ -0562                 | ▲ -1042                 |   | 2 X 2        | ▲ -0322                 | ▲ -0482                 | ▲ -0642                 | ▲ -1122                 |   |
|   |    | 2 X 3        | -0243                   | -0403                   | -0563                   | -1043                   |   | 2 X 3        | -0323                   | -0483                   | -0643                   | -1123                   |   |
|   |    | 2 X 4        | -0244                   | -0404                   | -0564                   | -1044                   |   | 2 X 4        | -0324                   | -0484                   | -0644                   | -1124                   |   |
|   |    | 2 X 5        | -0245                   | -0405                   | -0565                   | -1045                   |   | 2 X 5        | -0325                   | -0485                   | -0645                   | -1125                   |   |
|   |    | 2 X 6        | -0246                   | -0406                   | -0566                   | -1046                   |   | 2 X 6        | -0326                   | -0486                   | -0646                   | -1126                   |   |
|   |    | 2 X 7        | -0247                   | -0407                   | -0567                   | -1047                   |   | 2 X 7        | -0327                   | -0487                   | -0647                   | -1127                   |   |
|   |    | 2 X 8        | -0248                   | -0408                   | -0568                   | -1048                   |   | 2 X 8        | -0328                   | -0488                   | -0648                   | -1128                   |   |
|   |    | 2 X 9        | -0249                   | -0409                   | -0569                   | -1049                   |   | 2 X 9        | -0329                   | -0489                   | -0649                   | -1129                   |   |
|   |    | 2 X 10       | -0250                   | -0410                   | -0570                   | -1050                   |   | 2 X 10       | -0330                   | -0490                   | -0650                   | -1130                   |   |
|   |    | 2 X 11       | -0251                   | -0411                   | -0571                   | -1051                   |   | 2 X 11       | -0331                   | -0491                   | -0651                   | -1131                   |   |
|   |    | 2 X 12       | -0252                   | -0412                   | -0572                   | -1052                   |   | 2 X 12       | -0332                   | -0492                   | -0652                   | -1132                   |   |
|   |    | 2 X 13       | -0253                   | -0413                   | -0573                   | -1053                   |   | 2 X 13       | -0333                   | -0493                   | -0653                   | -1133                   |   |
|   |    | 2 X 14       | -0254                   | -0414                   | -0574                   | -1054                   |   | 2 X 14       | -0334                   | -0494                   | -0654                   | -1134                   |   |
|   |    | 2 X 15       | -0255                   | -0415                   | -0575                   | -1055                   |   | 2 X 15       | -0335                   | -0495                   | -0655                   | -1135                   |   |
|   |    | 2 X 16       | -0256                   | -0416                   | -0576                   | -1056                   |   | 2 X 16       | -0336                   | -0496                   | -0656                   | -1136                   |   |
|   |    | 2 X 17       | -0257                   | -0417                   | -0577                   | -1057                   |   | 2 X 17       | -0337                   | -0497                   | -0657                   | -1137                   |   |
|   |    | 2 X 18       | -0258                   | -0418                   | -0578                   | -1058                   |   | 2 X 18       | -0338                   | -0498                   | -0658                   | -1138                   |   |
|   |    | 2 X 19       | -0259                   | -0419                   | -0579                   | -1059                   |   | 2 X 19       | -0339                   | -0499                   | -0659                   | -1139                   |   |
|   |    | 2 X 20       | -0260                   | -0420                   | -0580                   | -1060                   |   | 2 X 20       | -0340                   | -0500                   | -0660                   | -1140                   |   |
|   |    | 2 X 21       | -0261                   | -0421                   | -0581                   | -1061                   |   | 2 X 21       | -0341                   | -0501                   | -0661                   | -1141                   |   |
|   |    | 2 X 22       | -0262                   | -0422                   | -0582                   | -1062                   |   | 2 X 22       | -0342                   | -0502                   | -0662                   | -1142                   |   |
|   |    | 2 X 23       | -0263                   | -0423                   | -0583                   | -1063                   |   | 2 X 23       | -0343                   | -0503                   | -0663                   | -1143                   |   |
|   |    | 2 X 24       | -0264                   | -0424                   | -0584                   | -1064                   |   | 2 X 24       | -0344                   | -0504                   | -0664                   | -1144                   |   |
|   |    | 2 X 25       | -0265                   | -0425                   | -0585                   | -1065                   |   | 2 X 25       | -0345                   | -0505                   | -0665                   | -1145                   |   |
|   |    | 2 X 26       | -0266                   | -0426                   | -0586                   | -1066                   |   | 2 X 26       | -0346                   | -0506                   | -0666                   | -1146                   |   |
|   |    | 2 X 27       | -0267                   | -0427                   | -0587                   | -1067                   |   | 2 X 27       | -0347                   | -0507                   | -0667                   | -1147                   |   |
|   |    | 2 X 28       | -0268                   | -0428                   | -0588                   | -1068                   |   | 2 X 28       | -0348                   | -0508                   | -0668                   | -1148                   |   |
|   |    | 2 X 29       | -0269                   | -0429                   | -0589                   | -1069                   |   | 2 X 29       | -0349                   | -0509                   | -0669                   | -1149                   |   |
|   |    | 2 X 30       | -0270                   | -0430                   | -0590                   | -1070                   |   | 2 X 30       | -0350                   | -0510                   | -0670                   | -1150                   |   |
|   |    | 2 X 31       | -0271                   | -0431                   | -0591                   | -1071                   |   | 2 X 31       | -0351                   | -0511                   | -0671                   | -1151                   |   |
|   |    | 2 X 32       | -0272                   | -0432                   | -0592                   | -1072                   |   | 2 X 32       | -0352                   | -0512                   | -0672                   | -1152                   |   |
|   |    | 2 X 33       | -0273                   | -0433                   | -0593                   | -1073                   |   | 2 X 33       | -0353                   | -0513                   | -0673                   | -1153                   |   |
|   |    | 2 X 34       | -0274                   | -0434                   | -0594                   | -1074                   |   | 2 X 34       | -0354                   | -0514                   | -0674                   | -1154                   |   |
|   |    | 2 X 35       | -0275                   | -0435                   | -0595                   | -1075                   |   | 2 X 35       | -0355                   | -0515                   | -0675                   | -1155                   |   |
|   |    | 2 X 36       | -0276                   | -0436                   | -0596                   | -1076                   |   | 2 X 36       | -0356                   | -0516                   | -0676                   | -1156                   |   |
|   |    | 2 X 37       | -0277                   | -0437                   | -0597                   | -1077                   |   | 2 X 37       | -0357                   | -0517                   | -0677                   | -1157                   |   |
|   |    | 2 X 38       | -0278                   | -0438                   | -0598                   | -1078                   |   | 2 X 38       | -0358                   | -0518                   | -0678                   | -1158                   |   |
|   |    | 2 X 39       | ▼ -0279                 | ▼ -0439                 | ▼ -0599                 | ▼ -1079                 |   | 2 X 39       | ▼ -0359                 | ▼ -0519                 | ▼ -0679                 | ▼ -1159                 |   |
|   |    | 2 X 40       | 90122-0280              | 90122-0440              | 90122-0600              | 90122-1080              |   | 2 X 40       | 90122-0360              | 90122-0520              | 90122-0680              | 90122-1160              |   |

DIM C (±0.20) ±.008 (5.75) .266

DIM D (±0.25) ±.010 (4.50) .177

DIM C (±0.20) ±.008 (6.75) .266

DIM D (±0.25) ±.010 (4.50) .177

NOTES:  
FOR PLATING VARIATIONS SEE  
ENG.STD. SDES-99000-0003.

|                   |            |                   |
|-------------------|------------|-------------------|
| REVISE PIN DIM    | 2011/10/21 | QUALITY SYMBOLS   |
| EC NO: S2012-0325 | 2011/10/31 | ▽ <sub>A</sub> =0 |
| DRWN:SKANG        | 2011/10/31 | ▽ <sub>E</sub> =0 |
| CHKD:ATSEE        | 2011/10/31 | ▽ <sub>B</sub> =0 |
| APPR:MLONG        |            |                   |
| REV               |            |                   |

|  |                 |   |              |                        |
|--|-----------------|---|--------------|------------------------|
| GENERAL TOLERANCES (UNLESS SPECIFIED)                | DIMENSION STYLE | SCALE   | DESIGN UNITS | THIRD ANGLE PROJECTION |
|  | MM ONLY         | NTS   | METRIC       |                        |
| 4 PLACES ± --- ± ---                                 | DRAWN BY        | DATE  | TITLE        |                        |
| 3 PLACES ± --- ± ---                                 | DB              | 16/07/87  |              |                        |
| 2 PLACES ± 0.05 ± .002                               | CHECKED BY      | DATE  |              |                        |
| 1 PLACE ± --- ± ---                                  | DB              | 1987/07/16  |              |                        |
| ANGULAR ± ---°                                       | APPROVED BY     | DATE  |              |                        |
|  | DB              | 1987/07/16  |              |                        |
| DRAFT WHERE APPLICABLE MUST REMAIN WITHIN DIMENSIONS | MATERIAL NO.    | DOCUMENT NO.  | SHEET NO.    |                        |
|  | SEE TABLE       | SDA-90122   | 6 OF 6       |                        |
|  | SIZE A3         | THIS DRAWING CONTAINS INFORMATION THAT IS PROPRIETARY TO MOLEX INCORPORATED AND SHOULD NOT BE USED WITHOUT WRITTEN PERMISSION |              |                        |

**MOLEX INCORPORATED**  
**C-GRID III**  
**DUAL ROW RIGHT**  
**ANGLE HEADER**