



Chipsmall Limited consists of a professional team with an average of over 10 year of expertise in the distribution of electronic components. Based in Hongkong, we have already established firm and mutual-benefit business relationships with customers from,Europe,America and south Asia,supplying obsolete and hard-to-find components to meet their specific needs.

With the principle of "Quality Parts,Customers Priority,Honest Operation,and Considerate Service",our business mainly focus on the distribution of electronic components. Line cards we deal with include Microchip,ALPS,ROHM,Xilinx,Pulse,ON,Everlight and Freescale. Main products comprise IC,Modules,Potentiometer,IC Socket,Relay,Connector.Our parts cover such applications as commercial,industrial, and automotives areas.

We are looking forward to setting up business relationship with you and hope to provide you with the best service and solution. Let us make a better world for our industry!



Contact us

Tel: +86-755-8981 8866 Fax: +86-755-8427 6832

Email & Skype: info@chipsmall.com Web: www.chipsmall.com

Address: A1208, Overseas Decoration Building, #122 Zhenhua RD., Futian, Shenzhen, China



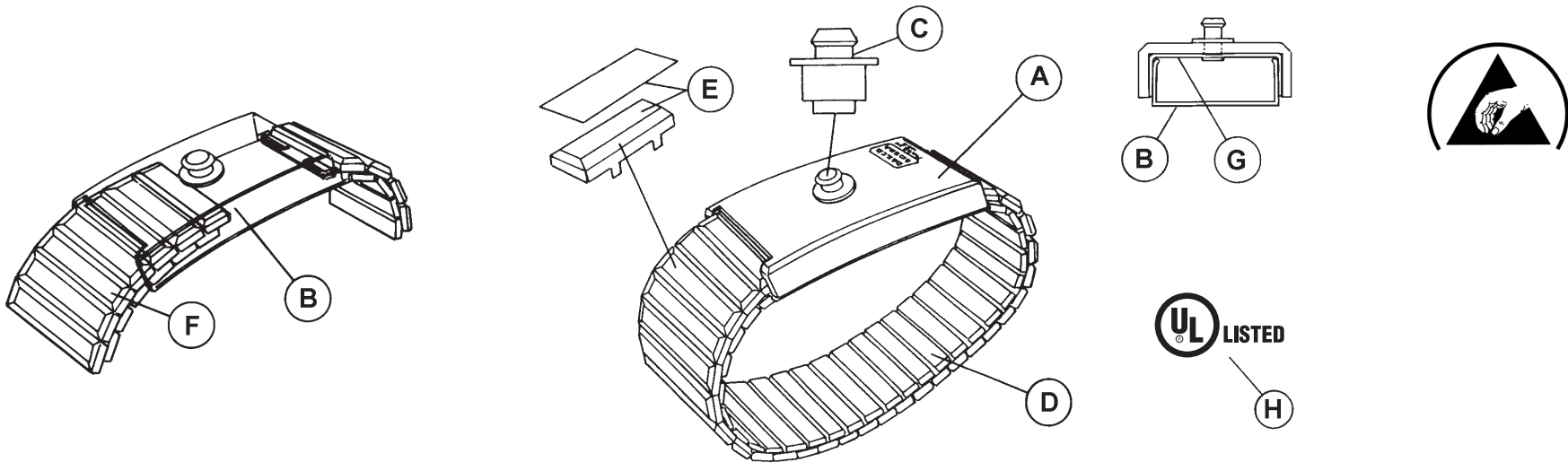

- A. Fixed black ABS cap with slotted opening to allow size adjustment.
- B. 300 Series Stainless Steel Backplate forms channel to hold up to 10 links of band allowing size adjustment.
- C. 4mm snap stud machined from 300 series stainless steel. Fits to 4mm spring loaded medical type socket. Coil cord disengages from snap with 1-5 lbs. of perpendicular force. Durable, providing long life well beyond that of sheet metal snaps.
- D. Premium metal expansion wrist strap. Inside links are constructed of 300 Series Stainless Steel. Width of links is 0.630".

- E. .002" polyphenylsulfone sheet is laminated to each link. Provides >5,000 volt RMS insulation per ASTM D149. Scratch resistant.
- F. Size is adjusted by sliding 1 to 10 links of the band into the backplate "C" channel.
- G. 300 Series Stainless Steel clip for electrical contact between snap stud and backplate.
- H. Underwriters Laboratory listing 90P1C.

Meets or exceeds requirements of EOS/ESD-S1-1987.

Item	Description	Circumference		Width
		Minimum	Maximum	
09200	Band only, red and blue	5.75 in.	13 in.	0.630"
09041	Band only, black	5.75 in.	13 in.	0.630"
09042	Band only, X-large, black	6.25 in.	14.5 in.	0.630"
09085	Band black with 6 ft. coil cord	5.75 in.	13 in.	0.630"
91070	Band black, 6ft. cord & angle banana, black	5.75 in.	13 in.	0.630"

Meets ESD S1.1 cuff resistance interior =100 kilohms (1 x 10E2 ohms)
 Meets ESD S1.1 cuff resistance exterior =10 megohms (1 x 10E7 ohms)

Unless otherwise noted, tolerance $\pm 10\%$

Specifications and procedures subject to change without notice.



Made in America

Premium Metal Expansion Wrist Straps

DESCO

DESCO WEST: 3651 WALNUT AVE., CHINO, CA 91710 WEB SITE: Desco.com
 PHONE (909) 627-8178 FAX (909) 627-7449
 DESCO EAST: ONE COLGATE WAY, CANTON, MA 02021-1407
 PHONE (781) 821-8370 FAX (781) 575-0172

DRAWING NUMBER
09041

DATE:
April
2011