



Chipsmall Limited consists of a professional team with an average of over 10 year of expertise in the distribution of electronic components. Based in Hongkong, we have already established firm and mutual-benefit business relationships with customers from,Europe,America and south Asia,supplying obsolete and hard-to-find components to meet their specific needs.

With the principle of “Quality Parts,Customers Priority,Honest Operation,and Considerate Service”,our business mainly focus on the distribution of electronic components. Line cards we deal with include Microchip,ALPS,ROHM,Xilinx,Pulse,ON,Everlight and Freescale. Main products comprise IC,Modules,Potentiometer,IC Socket,Relay,Connector.Our parts cover such applications as commercial,industrial, and automotives areas.

We are looking forward to setting up business relationship with you and hope to provide you with the best service and solution. Let us make a better world for our industry!



Contact us

Tel: +86-755-8981 8866 Fax: +86-755-8427 6832

Email & Skype: info@chipsmall.com Web: www.chipsmall.com

Address: A1208, Overseas Decoration Building, #122 Zhenhua RD., Futian, Shenzhen, China





Made in the United States of America

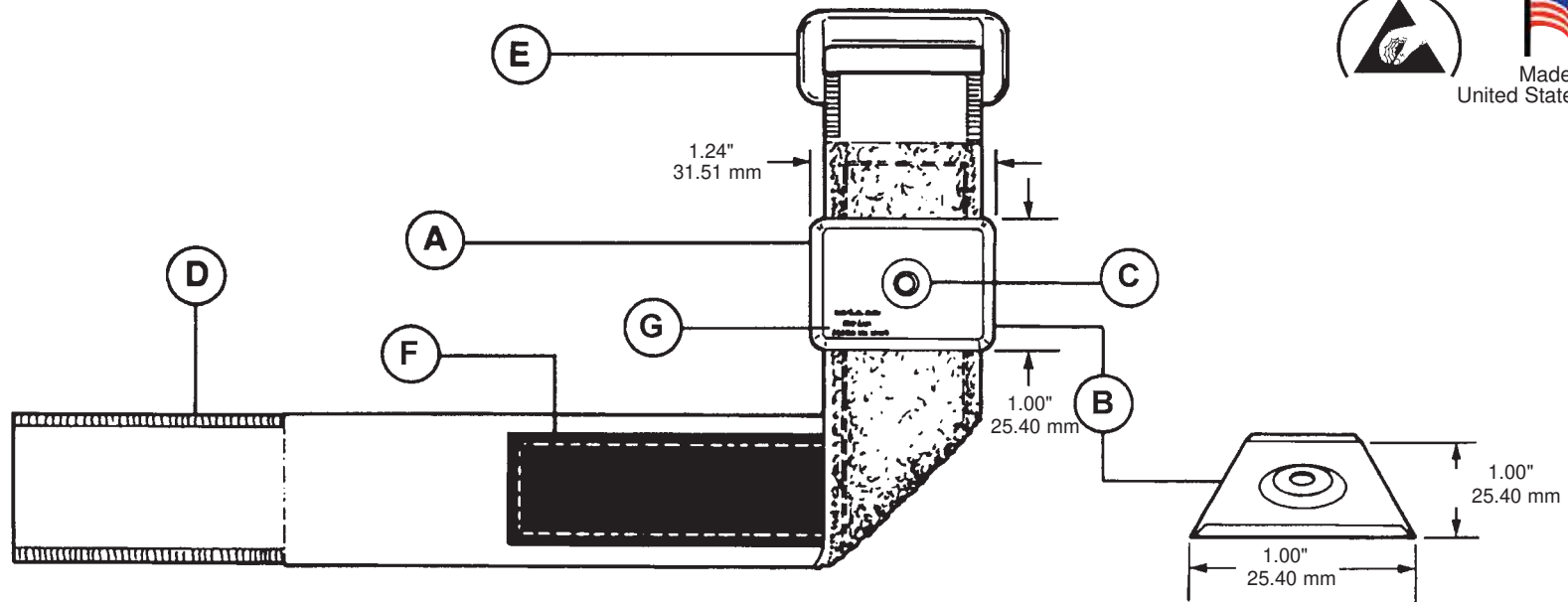

- A. Cap - ABS plastic, black
- B. 300 Series stainless steel back plate is .021" thick. Provides 1.0 sq. in. of skin contact surface.
- C. 4mm snap stud machined from 300 series stainless steel. Fits to 4mm spring loaded medical type socket. Coil cord disengages from snap with 1-5 lbs. of perpendicular force. Durable, providing long life well beyond that of sheet metal snaps.
- D. Nylon, hook fastener is royal blue, 25mm (1.0") wide. 25mm (1.0") nylon royal blue loop fastener material. Functional band circumference 6.50" min. and 10.75" max. assumes all but .50" of hook material is trimmed off to avoid overlapping. No exposed conductive surfaces when worn.
- E. Return loop for quick and easy adjustment.
- F. Sewn in non-reactive, anti-microbial, anti-bacterial medical grade conductive strip common with stainless plate adds 4 sq. in. of skin surface area contact.
- G. Desco, Item # and Made in USA are molded into cap.

Meets or exceeds requirements ANSI/ESD S1.1 and ESD TR53.

ITEM	Description
09060	Wristband only
09078	Wristband with 6 ft. coil cord

Unless otherwise noted, tolerance is $\pm 10\%$
Specifications and procedure subject to change without notice.

WRISTBAND, HOOK AND LOOP, ADJUSTABLE

DESCO

DESCO WEST: 3651 WALNUT AVE., CHINO, CA 91710 WEB SITE: Desco.com
PHONE (909) 627-8178 FAX (909) 627-7449
DESCO EAST: ONE COLGATE WAY, CANTON, MA 02021-1407
PHONE (781) 821-8370 FAX (781) 575-0172

DRAWING NUMBER
09060

DATE:
December
2011