



Chipsmall Limited consists of a professional team with an average of over 10 year of expertise in the distribution of electronic components. Based in Hongkong, we have already established firm and mutual-benefit business relationships with customers from,Europe,America and south Asia,supplying obsolete and hard-to-find components to meet their specific needs.

With the principle of "Quality Parts,Customers Priority,Honest Operation,and Considerate Service",our business mainly focus on the distribution of electronic components. Line cards we deal with include Microchip,ALPS,ROHM,Xilinx,Pulse,ON,Everlight and Freescale. Main products comprise IC,Modules,Potentiometer,IC Socket,Relay,Connector.Our parts cover such applications as commercial,industrial, and automotives areas.

We are looking forward to setting up business relationship with you and hope to provide you with the best service and solution. Let us make a better world for our industry!



Contact us

Tel: +86-755-8981 8866 Fax: +86-755-8427 6832

Email & Skype: info@chipsmall.com Web: www.chipsmall.com

Address: A1208, Overseas Decoration Building, #122 Zhenhua RD., Futian, Shenzhen, China



Types D, E, F, FM, 2F, F9, interface connectors I/U

Page

Technical characteristics types D and E **02.10**

Type D connectors **02.11**

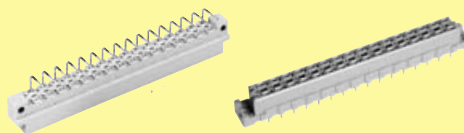

Type E connectors **02.15**

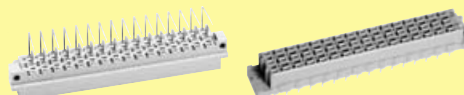

Technical characteristics piggyback connectors **02.20**

Piggyback connectors **02.21**

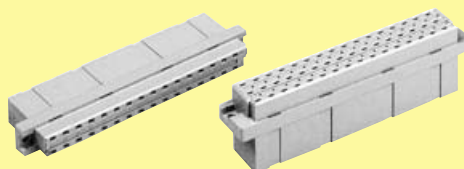

Technical characteristics types F, F9, FM and 2F **02.24**

Type F connectors **02.25**

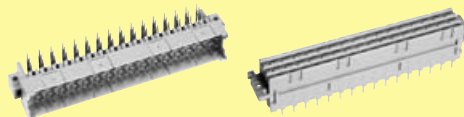

Type F9 connectors **02.35**



Type FM connectors **02.36**

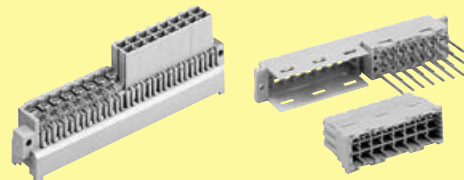

Type 2F connectors **02.38**

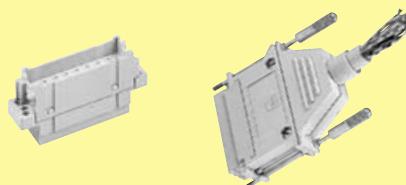

Coding systems **02.41**

DIN Power
to 6 A

Number of contacts	
Type D	32
Type E	48
Contact spacing (mm)	
Type D	5,08
Type E	male connector 5.08 x 5.08 male connector 2.54 x 5.08 female connector 5.08 x 5.08
Working current	6 A max. see current carrying capacity chart
Clearance	
Types D und E	≥ 3.0 mm
Type E male connector row separation 2.54 mm	≥ 1.6 mm
Creepage	≥ 3.0 mm
Working voltage	
The working voltage also depends on the clearance and creepage dimensions of the pcb itself and the associated wiring	according to the safety regulations of the equipment Explanations see chapter 00
Test voltage $U_{r.m.s.}$	1.55 kV
Contact resistance	≤ 15 mΩ for wire wrap and solder connections ≤ 20 mΩ including crimp connections
Insulation resistance	≥ 10 ¹² Ω
Temperature range	- 55 °C ... + 125 °C
The higher temperature limit includes the local ambient and heating effects of the contacts under load	
Degree of protection for crimp terminal	IP 20 according to DIN 40 050
Electrical termination	
Male connector	Solder pins for pcb connections Ø 1.0 ± 0.1 mm according to IEC 60 326-3
Female connector	Wrap posts 1 x 1 mm diagonal 1.34-1.45 mm Solder pins for pcb connections Ø 1.0 ± 0.1 mm according to IEC 60 326-3 Angled solder pins 1 x 1 mm for pcb connections Ø 1.6 ± 0.1 mm Solder lugs Crimp terminal 0.09-1.5 mm ²
Insertion and withdrawal force	32 way ≤ 40 N 48 way ≤ 75 N
Materials	
Mouldings	Thermoplastic resin, glass-fibre filled, UL 94-V0
Contacts	Copper alloy
Contact surface	
Contact zone	Selectively gold plated according to performance level ¹⁾

¹⁾ Explanation of performance levels see chapter 00

Mating conditions	see chapter 00
Coding systems	see pages 02.41 and 02.42
Mounting clips	see chapter 00

Current carrying capacity

The current carrying capacity is limited by maximum temperature of materials for inserts and contacts including terminals. The current capacity curve is valid for continuous, non interrupted current loaded contacts of connectors when simultaneous power on all contacts is given, without exceeding the maximum temperature.

Control and test procedures according to DIN IEC 60 512

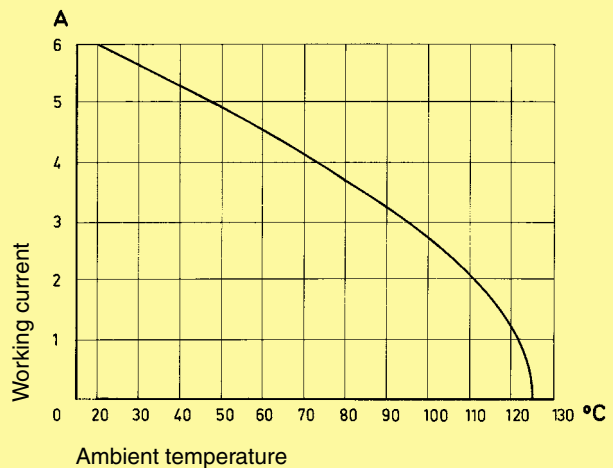

Fitting the crimp contacts

After crimping the wires onto the contacts with the help of a crimping tool or an automatic crimping machine the contacts should be correctly oriented and inserted into the cavities of the connector moulding in the required configuration. They snap into position and are firmly held in place. A light pull on the wire assures the correct tensile strength of the contact. When using stranded wires with a gauge below 0.37 mm² an insertion tool is necessary.

Removing the crimp contacts

The removal tool is inserted into a slot on the side of the respective crimp cavity. This action compresses the contact retaining spring therefore the contact can then be easily withdrawn using a light pull on the wire. This action will cause no damage to the contact/wire which can be repositioned/refitted as necessary. The drawing demonstrates the crimp removal procedure (max. 5x).

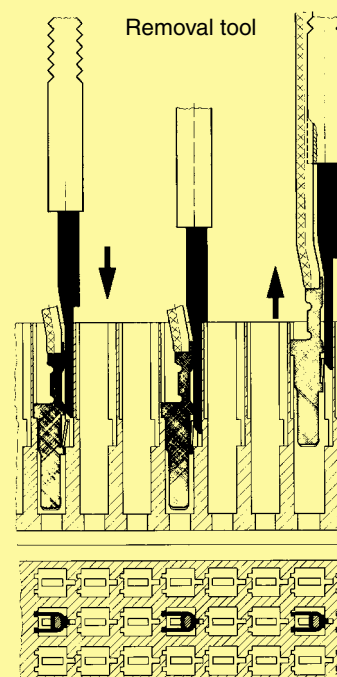

Number of contacts

32

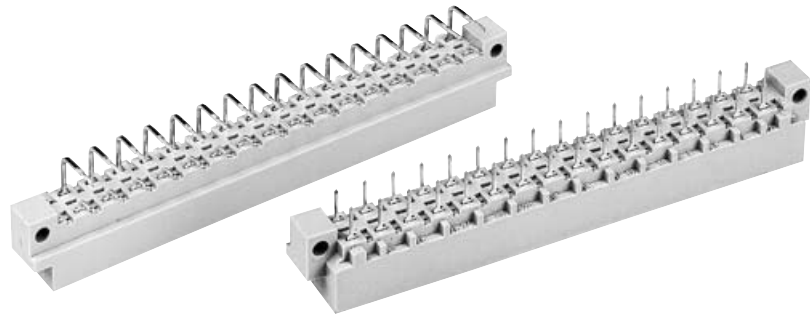

Male connectors

Identification	Number of contacts	Contact arrangement	Part No.	Performance levels according to IEC 60603-2. Explanation chapter 00	
			3	2	1
Male connector with angled solder pins	32		09 04 132 7921	09 04 132 6921 09 04 332 6921 ^{b)} 09 04 632 6921 ^{c)}	09 04 132 2921
	30 + 2 [▲]			09 04 132 6951 09 04 632 6951 ^{c)}	09 04 632 2951 ^{c)}
Male connector with straight solder pins	32			09 04 132 6922	
	30 + 2 [▲]			09 04 132 6952	

DIN Power
10 6 A

Dimensions

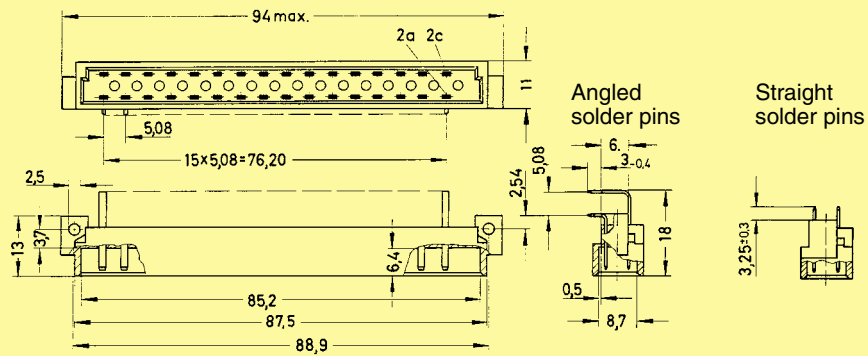

Board drillings
Mounting side

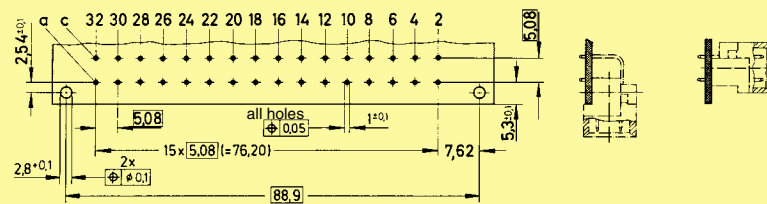

Dimensions in mm

▲ Male connectors with 2 leading contacts [(0.8 mm) pos. a2 and a32]
Other contact arrangements on request
b) Connectors with snap-in clips see chapter 00
c) Connectors with coding see page 02.42

Number of contacts

32

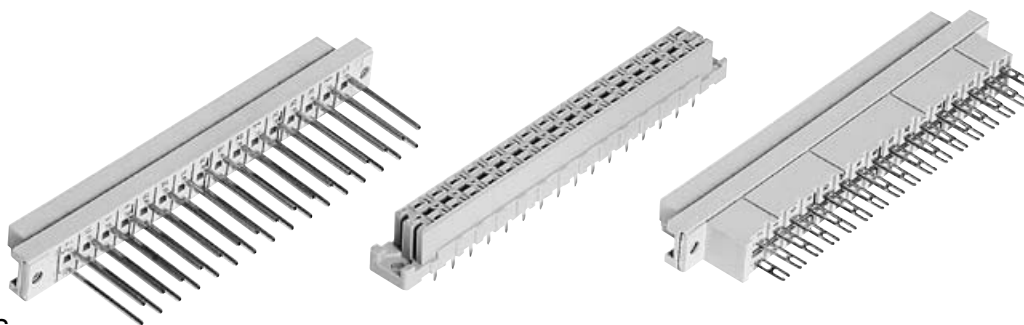

Female connectors

DIN Power
to 6 A

Identification Number of contacts Contact arrangement Part No. Performance levels according to IEC 60 603-2. Explanation chapter 00

			3	2	1
Female connector with solder pins 2.9 mm	32		09 04 232 7832	09 04 232 6832 09 04 732 6832 ^{c)}	09 04 232 2832
Female connector with solder pins 4.5 mm	32		09 04 232 7831	09 04 232 6831 09 04 332 6831 ^{b)} 09 04 732 6831 ^{c)}	09 04 232 2831
Female connector with wrap posts 20 mm	32		09 04 232 7821	09 04 232 6821 09 04 732 6821 ^{c)}	09 04 232 2821
Female connector with solder lugs	32		09 04 232 7823	09 04 232 6823	09 04 232 2823

Dimensions

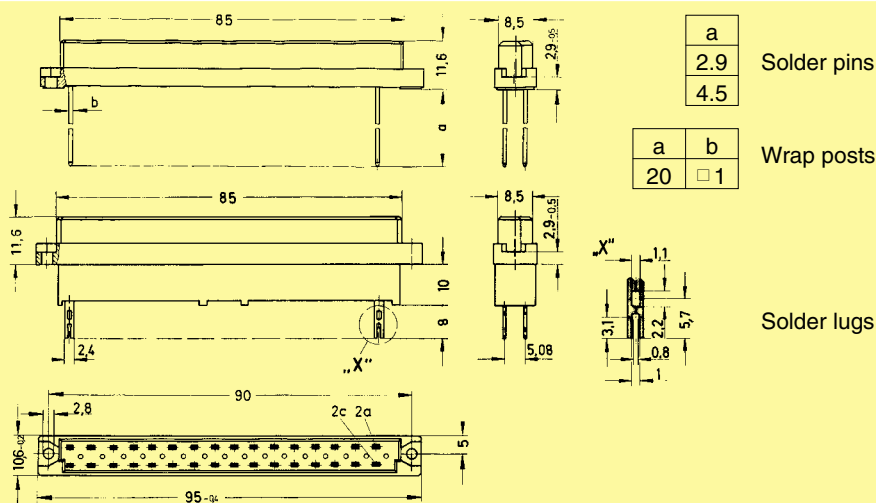

Panel cut out

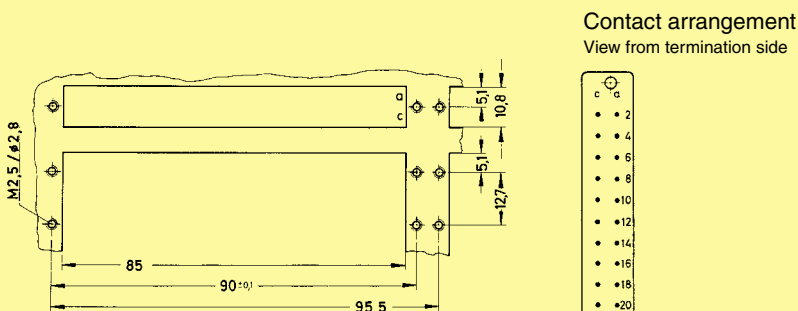

Board drillings

Mounting side

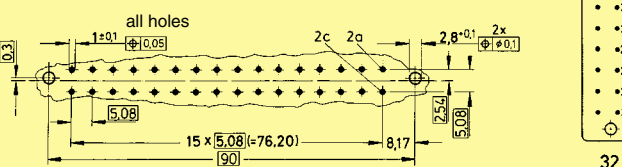

Dimensions in mm

^{b)} Connectors with snap-in clips see chapter 00

^{c)} Connectors with coding see page 02.42

Number of contacts

32



Female connectors

Identification	Number of contacts	Contact arrangement	Part No.	Performance levels according to IEC 60603-2. Explanation chapter 00	
			3	2	1

Female connector with angled solder pins 1 x 1 mm

32



09 04 232 7826

09 04 232 6826

09 04 232 2826

Dimensions

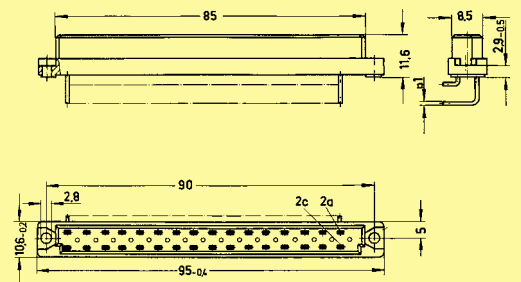

Fixing bracket Metal

09 06 000 9912¹⁾

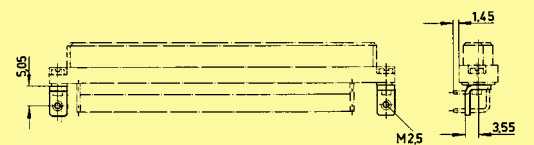

¹⁾ order 2 pieces for one connector

Board drillings Mounting side

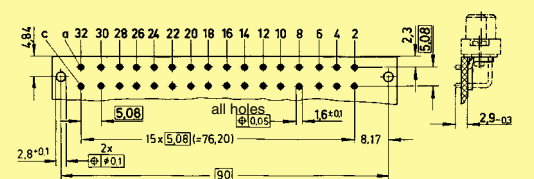

Dimensions in mm

DIN Power
10 6 A

Number of contacts

max. 32

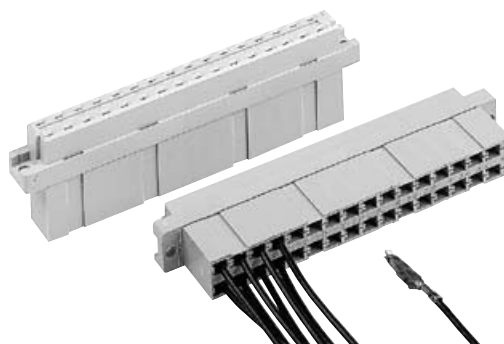

Female connectors

DIN Power
10 6 A

Identification	Number of contacts	Part No.	Drawing	Dimensions in mm
Female connector for crimp contacts Order contacts separately	32	09 04 032 3213	<p>85, 84, 11.5, 14.8, 8.5, 2.9±0.08, 10, 2.8+0.1, 90±0.1, 2c, 2a, 5.08, 5, 10.6±0.1, 15 x 5.08 = 76.20, 8.17, 95-0.4</p> <p>Contact arrangement View from termination side</p>	<p>Shell housing 09 03 096 0501 see chapter 20</p>

Identification	Identification Wire gauge	Part No.	Performance levels according to IEC 60603-2. Explanation chapter 00
		2	1
Female crimp FC contacts			
Bandoliered contacts (approx. 2,500 pieces)	1	09 06 000 6484	09 06 000 6474
	2	09 06 000 6481	09 06 000 6471
	3	09 06 000 6482	09 06 000 6472
Bandoliered contacts (approx. 250 pieces)	1	09 06 000 7484	09 06 000 7474
	2	09 06 000 7481	09 06 000 7471
	3	09 06 000 7482	09 06 000 7472
Individual contacts ¹⁾	1	09 06 000 8484	09 06 000 8474
	2	09 06 000 8481	09 06 000 8471
	3	09 06 000 8482	09 06 000 8472
Female contacts with solder lugs ²⁾ (lockable)			09 06 000 6420

Identification	Wire gauge mm ²	AWG	Insulation ø mm	Identification
FC 1	0.09 - 0.25	28 - 24	0.7 - 1.5	<p>Bandoliered contacts</p> <p>Individual contacts</p>
FC 2	0.14 - 0.56	26 - 20	0.8 - 2.0	
FC 3	0.5 - 1.5	20 - 16	1.6 - 2.8	

3.5 + 0.5 mm of insulation is stripped from the wires to be crimped
Insertion, removal and crimping tools see chapter 30

¹⁾ Packaging unit 1,000 pieces

²⁾ Solder contacts must not be used together with shell housing A. Special contact surface: 2 µm gold.

Number of contacts

48



Male connectors

Identification	Number of contacts	Contact arrangement	Part No.	Performance levels according to IEC 60603-2. Explanation chapter 00
			3	2 1
Male connector with angled solder pins Row separation termination side 5.08 mm (I)	48		09 05 148 7921	09 05 148 6921 09 05 348 6921 ^{b)} 09 05 648 6921 ^{c)}
	46 + 2 [▲]			09 05 148 6951
	48		09 05 148 7931	09 05 148 6931
	46 + 2 [▲]			09 05 148 6961

DIN Power 10 6 A

Dimensions

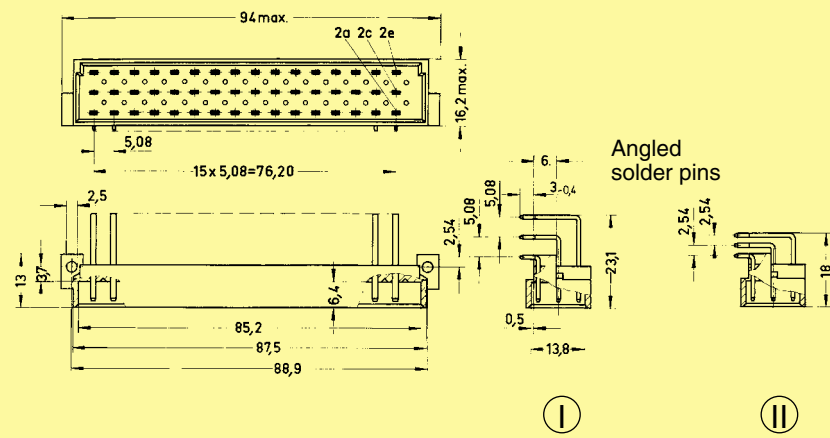

Board drillings
Mounting side

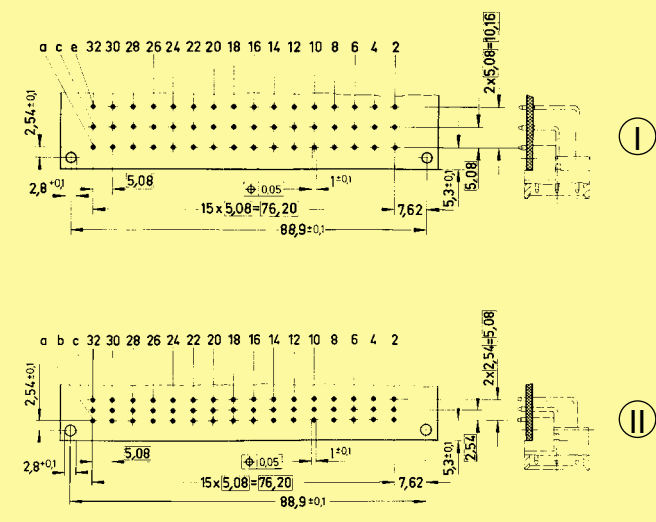

Dimensions in mm

▲ Male connectors with 2 leading contacts [(0.8 mm) pos. a2 and a32]
 Other contact arrangements on request
 b) Connectors with snap-in clips see chapter 00
 c) Connectors with coding see page 02.42

Number of contacts

48

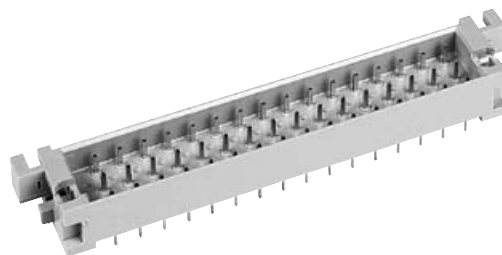

Interface connector I

DIN Power
to 6 A

Identification	Number of contacts	Part No.	Drawing	Dimensions in mm
----------------	--------------------	----------	---------	------------------

Interface connector I
with solder pins
0.6 x 0.6 mm

48

Performance level 2
acc. to IEC 60 603-2

09 05 048 6924

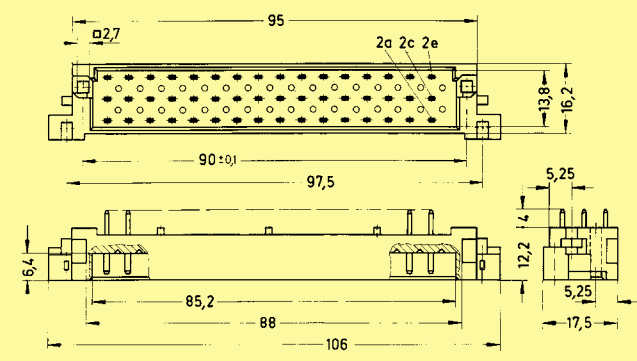

Contact arrangement View from termination side

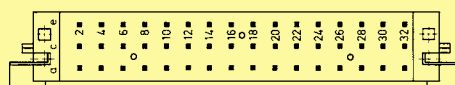

Panel cut out

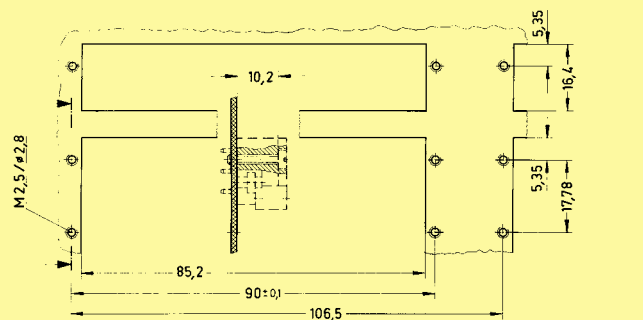

Board drillings
Mounting side

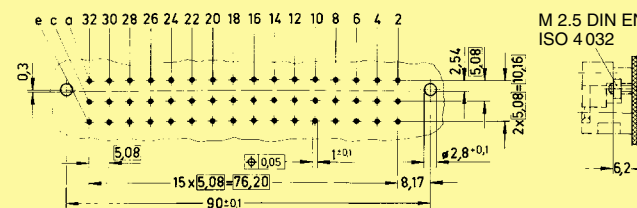

Number of contacts

48

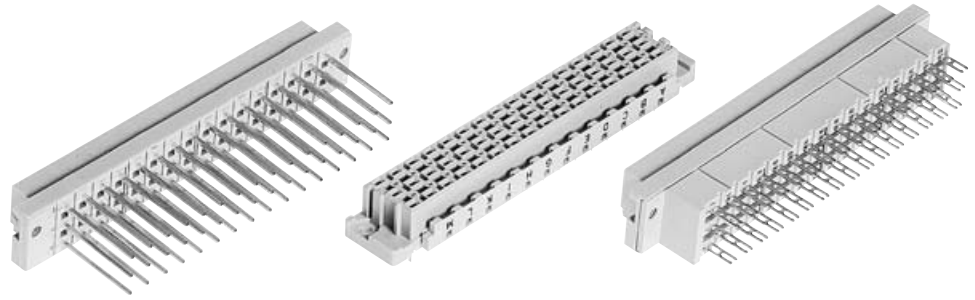

Female connectors

Identification	Number of contacts	Contact arrangement	Part No.	Performance levels according to IEC 60603-2. Explanation chapter 00
			3	2 1
Female connector with solder pins 2.9 mm	48		09 05 248 7832	09 05 248 6832 09 05 248 2832
Female connector with solder pins 4.5 mm	48		09 05 248 7831	09 05 248 6831 09 05 348 6831 ^{b)} 09 05 748 6831 ^{c)} 09 05 248 2831 09 05 748 2831 ^{c)}
Female connector with wrap posts 20 mm	48		09 05 248 7821	09 05 248 6821 09 05 248 2821
Female connector with solder lugs	48		09 05 248 7823	09 05 248 6823 09 05 248 2823

DIN Power 10 6 A

Female connector with press-in pins

Part Nos. and variants see chapter 04

Dimensions

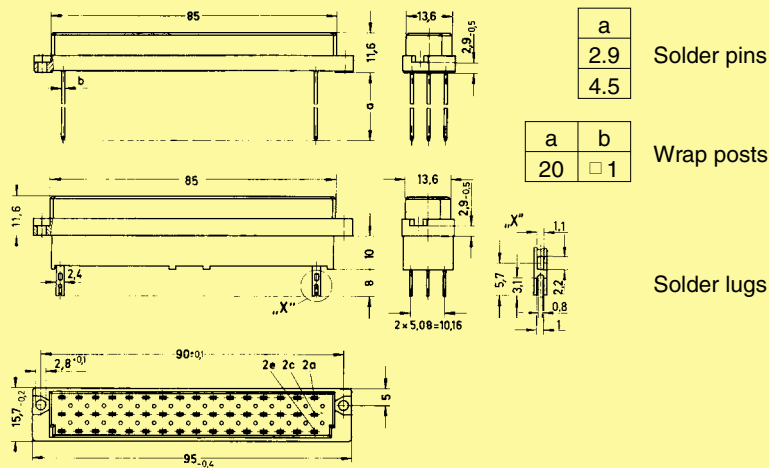

Panel cut out

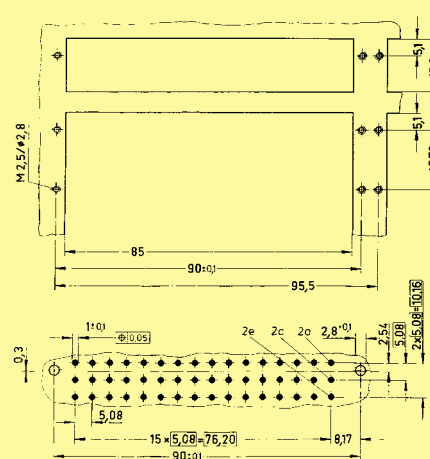

Contact arrangement
View from termination side

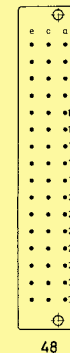

Board drillings

Mounting side

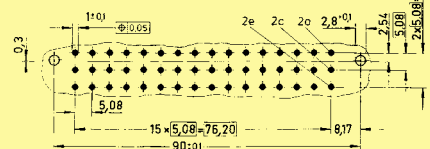

Dimensions in mm

^{b)} Connectors with snap-in clips see chapter 00
^{c)} Connectors with coding see page 02.42

Number of contacts

max. 48

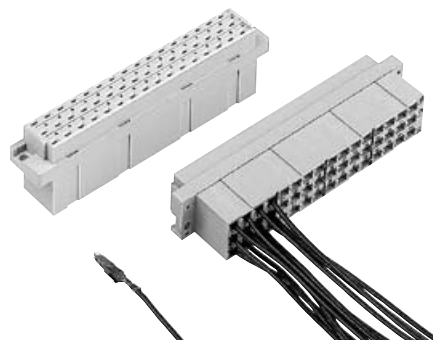

Female connectors

DIN Power
10 6 A

Identification	Number of contacts	Part No.	Drawing	Dimensions in mm
----------------	--------------------	----------	---------	------------------

Female connector for crimp contacts
Order contacts separately

48

09 05 048 3202
09 05 548 3202^{c)}

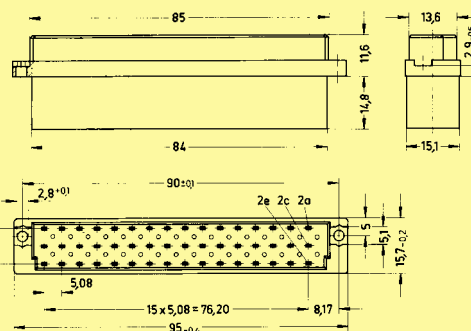

Contact arrangement View from termination side

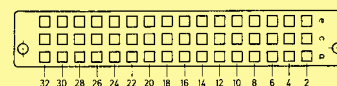

Shell housing 09 05 048 0501 see chapter 20

Identification	Identification Wire gauge	Part No.	Performance levels according to IEC 60603-2. Explanation chapter 00
----------------	---------------------------	----------	---------------------------------------------------------------------

Female crimp FC contacts

Bandoliered contacts (approx. 2,500 pieces)

1
2
3

09 06 000 6484
09 06 000 6481
09 06 000 6482

09 06 000 6474
09 06 000 6471
09 06 000 6472

Bandoliered contacts (approx. 250 pieces)

1
2
3

09 06 000 7484
09 06 000 7481
09 06 000 7482

09 06 000 7474
09 06 000 7471
09 06 000 7472

Individual contacts¹⁾

1
2
3

09 06 000 8484
09 06 000 8481
09 06 000 8482

09 06 000 8474
09 06 000 8471
09 06 000 8472

Female contacts with solder lugs²⁾ (lockable)

09 06 000 6420

FC 1
FC 2
FC 3

1
2
3

Wire gauge mm ²	AWG	Insulation ø mm
0.09 - 0.25	28 - 24	0.7 - 1.5
0.14 - 0.56	26 - 20	0.8 - 2.0
0.5 - 1.5	20 - 16	1.6 - 2.8

Identification

Bandoliered contacts

Individual contacts

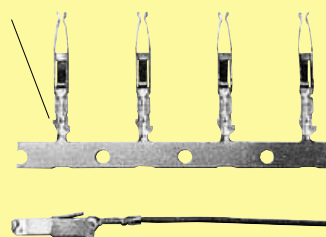

3.5 + 0.5 mm of insulation is stripped from the wires to be crimped

Insertion, removal and crimping tools see chapter 30

^{c)} Connectors with coding see page 02.42

¹⁾ Packaging unit 1,000 pieces

²⁾ Solder contacts must not be used together with shell housing A. Special contact surface: 2 µm gold.

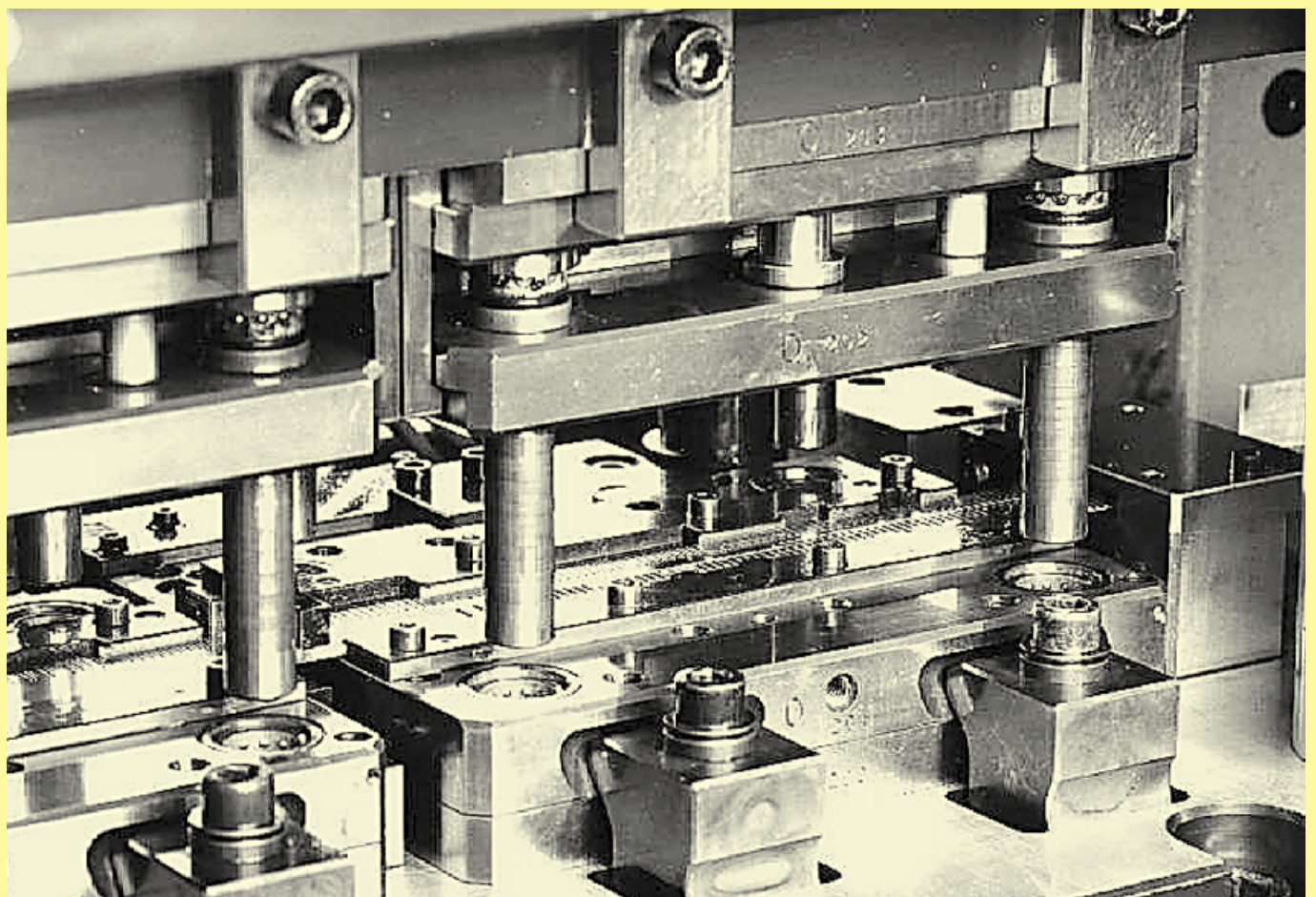

DIN Power
10 6 A



Our claim is quality.

Simultaneous and fully automated high-speed stamping of several contacts with small tolerances.

Number of contacts	16, 32, 48
Working current	6 A max. see current carrying capacity chart
Clearance	16 ways ≥ 1.6 mm 32, 48 ways ≥ 1.6 mm
Creepage	16 ways ≥ 1.6 mm 32, 48 ways ≥ 3.0 mm
Working voltage	The working voltage also depends on the clearance and creepage dimensions of the pcb itself and the associated wiring according to the safety regulations of the equipment Explanations see chapter 00
Contact resistance	≤ 20 m Ω
Insulation resistance	$\geq 10^{12}$ Ω
Termination	Crimp terminal 0.09-1.5 mm ²
Materials	Mouldings and hoods: Thermoplastic resin, glass-fibre filled Contacts: Copper alloy

Piggyback connectors for interfacing with female connectors with wrap posts 1 x 1 mm

The problem of interfacing systems designed for the distribution or collection of electronic signals can be overcome by the use of piggyback connectors. Designed to be mounted on the rear of DIN 41 612 type wire wrap female connectors (1 x 1 mm posts) these piggyback elements can be used to terminate input and output cables.

Distance fixing brackets are fitted to provide either a latching or screw fixing facility over the two level wire wrap plane.

The female crimp contacts used in these versions are designed for 1 x 1 mm posts.

After crimping they can be easily inserted into the chambers of the connector body with the aid of an insertion tool. Insertion errors can be simply rectified with the use of a removal tool.

2 and 3 row piggyback connectors can be mounted in shell housings C and open hood G. Security is provided by either latches or screws to the distance fixing brackets.

Current carrying capacity

The current carrying capacity is limited by maximum temperature of materials for inserts and contacts including terminals. The current capacity curve is valid for continuous, non interrupted current loaded contacts of connectors when simultaneous power on all contacts is given, without exceeding the maximum temperature.

Control and test procedures according to DIN IEC 60 512

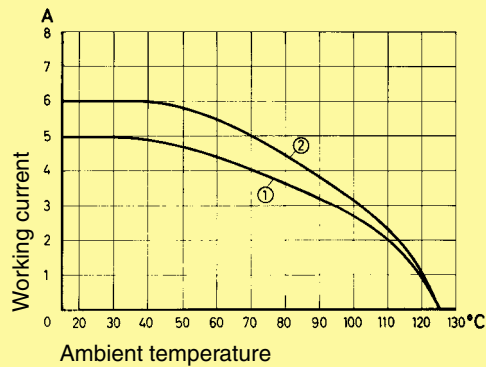

① with shell housing ② without shell housing

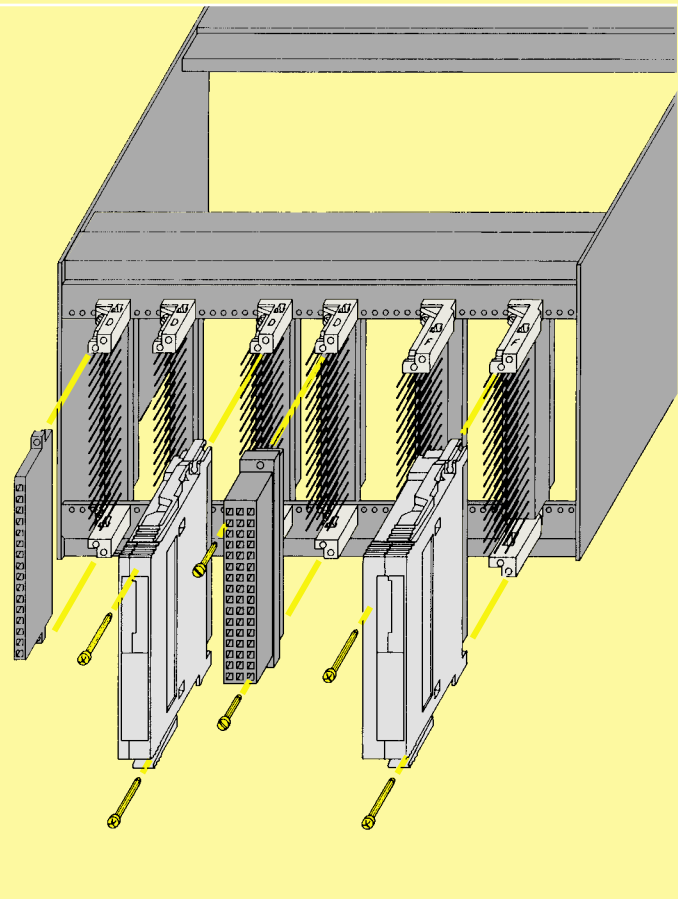

DIN Power
10 6 A

Piggyback connectors



Number of contacts

max. 48

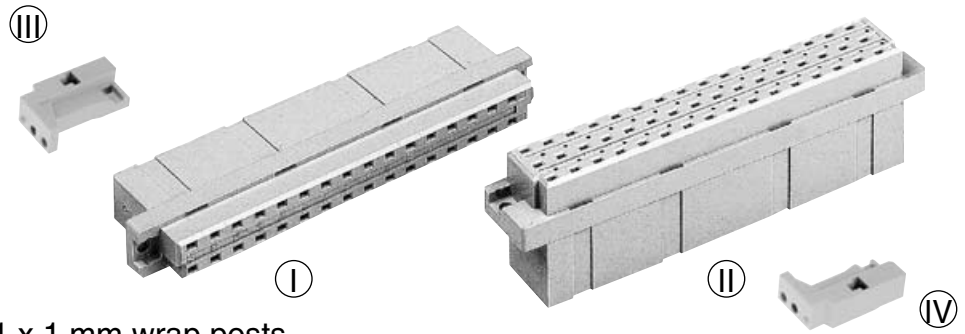

Piggyback connectors for 1 x 1 mm wrap posts

Identification Number of contacts Part No. Drawing Dimensions in mm

Piggyback connector for crimp contacts
Order contacts separately

16

09 04 016 3201

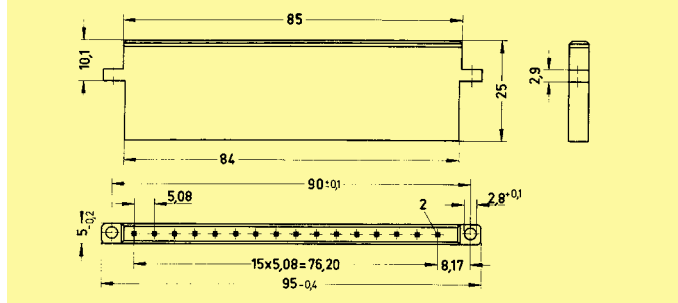

Ⓘ

32

09 04 032 3215

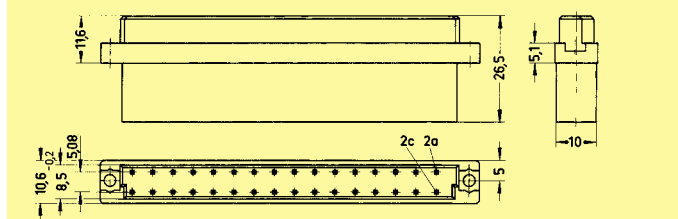

Ⓜ

48

09 05 048 3204

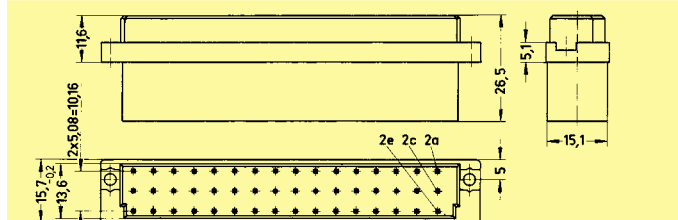

Female FC crimp contacts
FC1 individual contacts¹⁾
FC2
FC3
Bandoliered contacts
FC1 (approx. 2,500 pcs.)
FC2
FC3

09 06 000 6464
09 06 000 6461
09 06 000 6462
09 06 000 6454
09 06 000 6451
09 06 000 6452

Identification	Wire gauge mm ²	AWG	Insulations ø mm
1	0.09-0.25	28-24	0.7-1.5
2	0.14-0.56	26-20	0.8-2.0
3	0.50-1.50	20-16	1.6-2.8

Mateable with 1 x 1 mm wrap posts

3.5 + 0.5 mm of insulation is stripped from the wires to be crimped. Crimping tools see chapter 30

Distance fixing brackets for female connectors
Type D
Type E

top (pos. 2)
09 04 000 9907
bottom (pos. 32)
09 04 000 9906

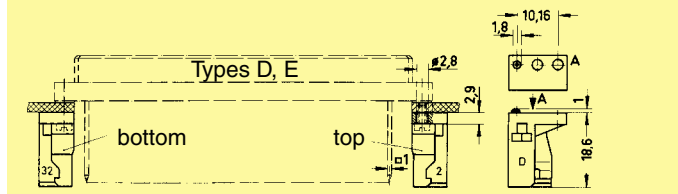

Type F

Ⓜ

top (pos. 2)
09 06 000 9936

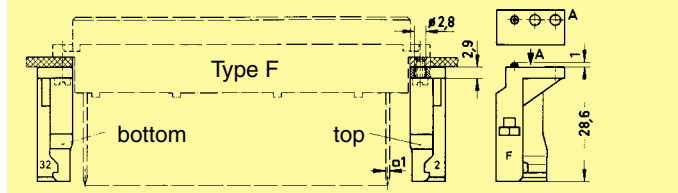

Ⓜ

bottom (pos. 32)
09 06 000 9937

DIN Power 10 6 A

¹⁾ Packaging unit 1,000 pieces

Identification

Drawing

Dimensions in mm

Mounting examples
of piggyback
connectors

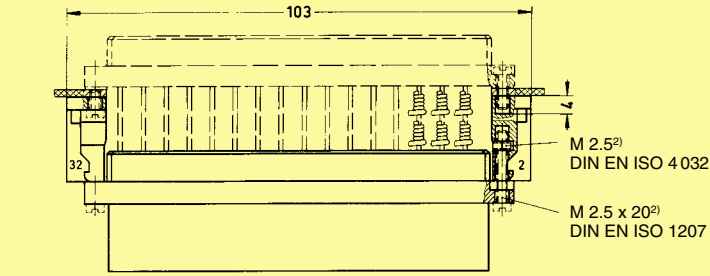

without housings

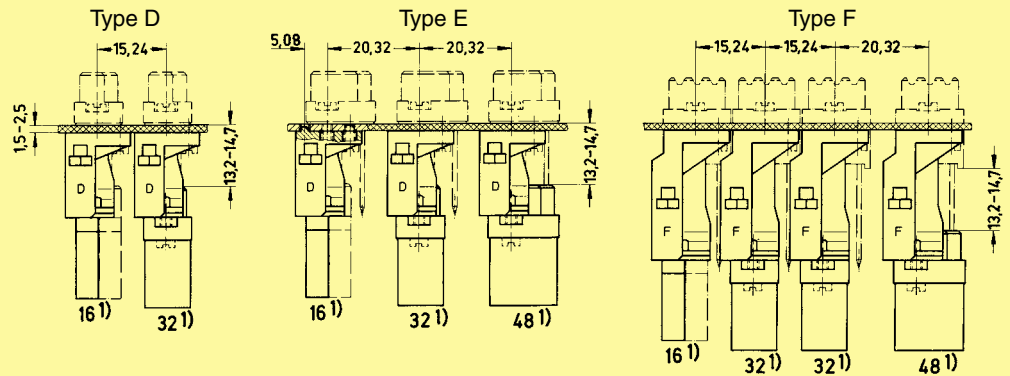

with housings

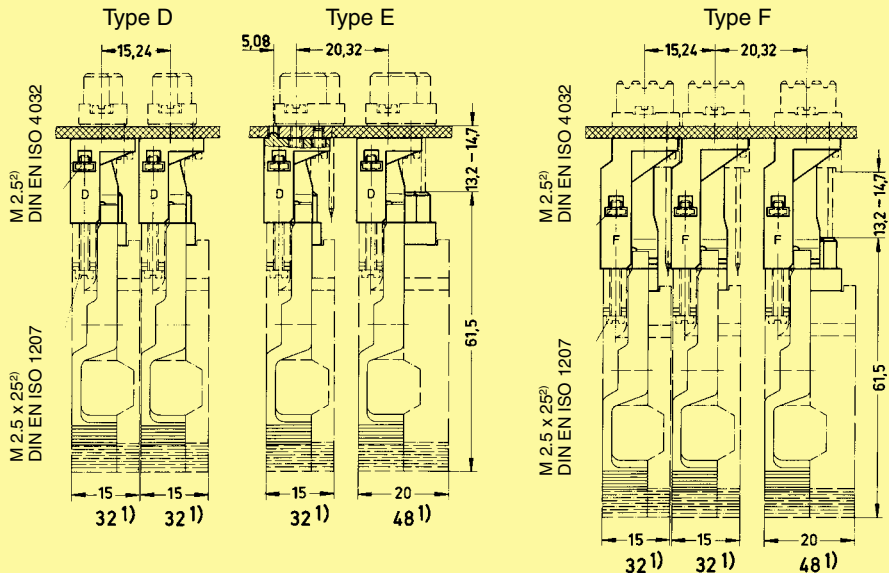
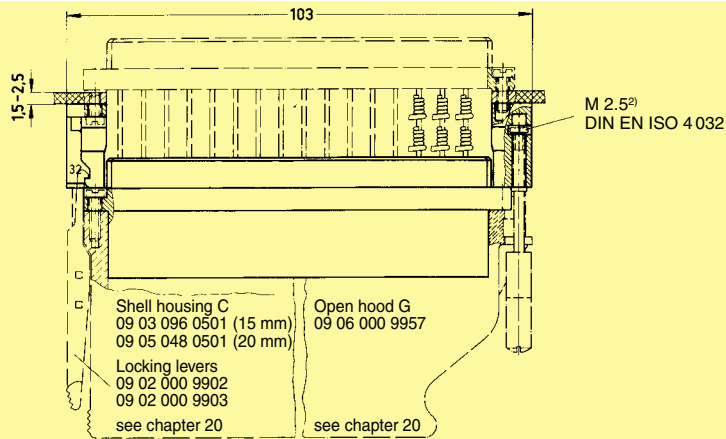

DIN Power
to 6 A

1) Number of contacts piggyback connector
2) Doesn't belong to the scope of supply



DIN Power
10 6 A

Number of contacts	
Type F	48, 32
Type FM	45
Type 2F	max. 24
Type F9	max. 9
Contact spacing (mm)	
	5.08
Working current	
	6 A max. see current carrying capacity chart
Clearance	
	≥ 1.6 mm
Creepage	
	≥ 3.0 mm
Working voltage	
The working voltage also depends on the clearance and creepage dimensions on the pcb itself and the associated wiring	according to the safety regulations of the equipment Explanations see chapter 00
Test voltage $U_{r.m.s.}$	
	1.55 kV (contact-contact) 2.5 kV (contact-ground)
Contact resistance	
	≤ 15 mΩ for wire wrap and solder connections ≤ 20 mΩ including crimp connections
Insulation resistance	
	≥ 10 ¹² Ω
Temperature range	
	- 55 °C ... + 125 °C The higher temperature limit includes the local ambient and heating effects of the contacts under load
Electrical termination	
Male connector	Solder pins for pcb connections Ø 1 ± 0.1 mm according to IEC 60 326-3 Wrap posts 1 x 1 mm diagonal 1.34-1.45 mm Crimp terminal 0.09-1.5 mm ²
Female connector	Wrap posts 1 x 1 mm diagonal 1.34-1.45 mm Solder pins for pcb connections Ø 1 ± 0.1 mm according to IEC 60 326-3 Angled solder pins 1 x 1 mm for pcb connections Ø 1.6 ± 0.1 mm Solder lugs Crimp terminal 0.09-1.5 mm ²
Distributor	Crimp terminal 0.09-1.5 mm ²
Insertion and withdrawal force	
	48 way ≤ 75 N 45 way ≤ 70 N 32 way ≤ 50 N 24 way ≤ 37 N
Materials	
Mouldings	Thermoplastic resin, glass-fibre filled, UL 94-V0
Contacts	Copper alloy
Contact surface	
Contact zone	Selectively plated according to performance level ¹⁾

¹⁾ Explanation of performance levels see chapter 00

Mating conditions see chapter 00
Coding systems see pages 02.41 and 02.42
Mounting clips see chapter 00

Current carrying capacity

The current carrying capacity is limited by maximum temperature of materials for inserts and contacts including terminals. The current capacity curve is valid for continuous, non interrupted current loaded contacts of connectors when simultaneous power on all contacts is given, without exceeding the maximum temperature.

Control and test procedures according to DIN IEC 60 512

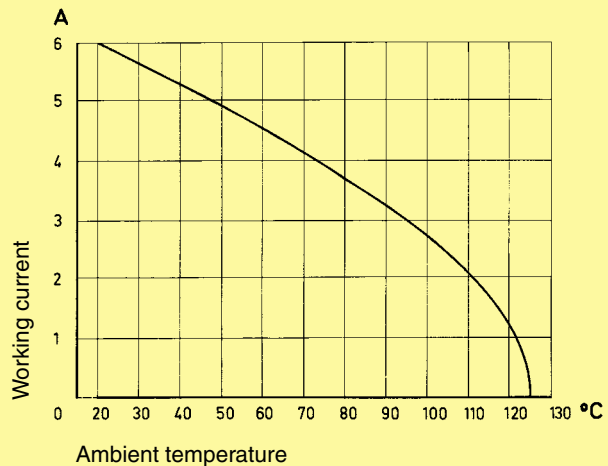

Fitting the crimp contacts

After crimping the wires onto the contacts with the help of a crimping tool or an automatic crimping machine the contacts should be correctly oriented and inserted into the cavities of the connector moulding in the required configuration. They snap into position and are firmly held in place. A light pull on the wire assures the correct tensile strength of the contact. When using stranded wires with a gauge below 0.37 mm² an insertion tool is necessary.

Removing the crimp contacts

The removal tool is inserted into a slot on the side of the respective crimp cavity. This action compresses the contact retaining spring therefore the contact can then be easily withdrawn using a light pull on the wire. This action will cause no damage to the contact/wire which can be repositioned/refitted as necessary. The drawing demonstrates the crimp removal procedure (max. 5x).

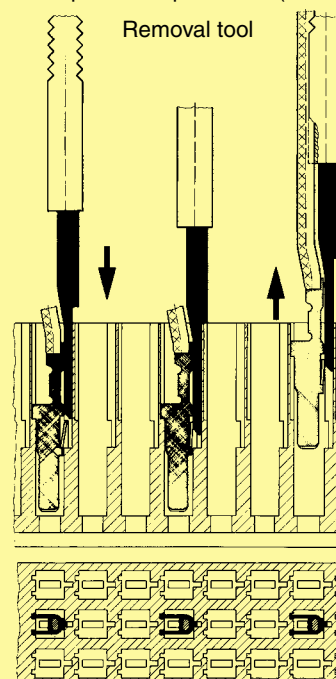

Number of contacts

48, 32

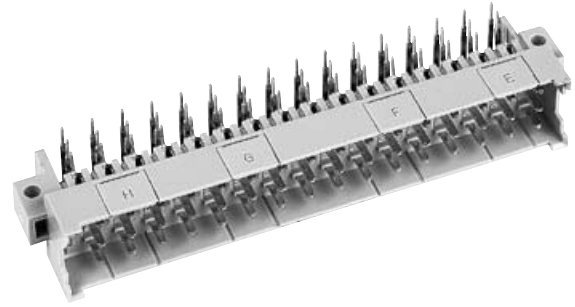

Male connectors

Identification	Number of contacts	Contact arrangement	Part No. Performance levels according to IEC 60603-2. Explanation chapter 00		
			3	2	1
Male connector with angled solder pins ¹⁾	48		09 06 148 7901	09 06 148 6901 09 06 348 6901 ^{b)}	09 06 148 2901
	32		09 06 132 7901 09 06 332 7901 ^{b)}	09 06 132 6901	09 06 132 2901
	32		09 06 132 7931	09 06 132 6931 09 06 332 6931 ^{b)}	09 06 132 2931
	47 + 1			09 06 148 6921 09 06 348 6921 ^{b)}	09 06 148 2921
	31 + 1		09 06 132 7921	09 06 132 6921	09 06 132 2921
2 leading contacts (positions b 2 + b 32)	46 + 2			09 06 148 6925	09 06 148 2925

DIN Power 10 6 A

Dimensions

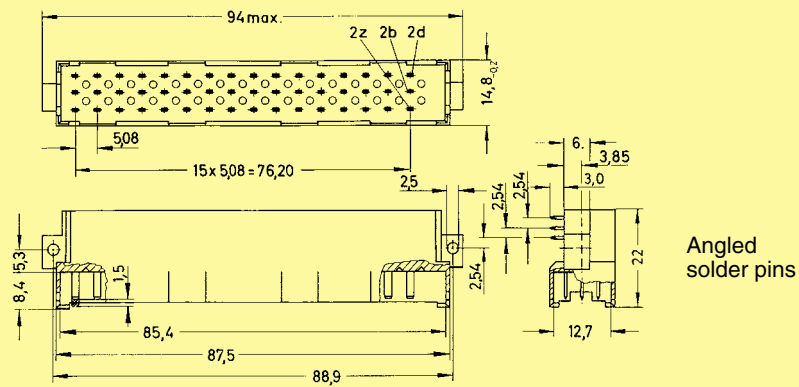

Board drillings

Mounting side

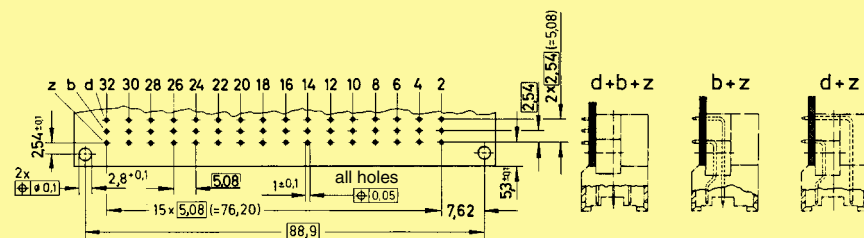

Dimensions in mm

¹⁾ With shroud coding, see also page 02.41

^{b)} Connectors with snap-in clips see chapter 00

Number of contacts

48, 32

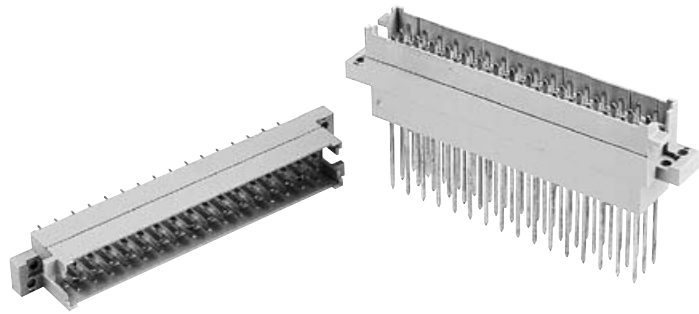

Interface connectors I

DIN Power to 6 A

Identification	Number of contacts	Contact arrangement	Part No.	Drawing	Dimensions in mm
Interface connector I with solder pins ¹⁾ 0.6 x 0.6 mm	48		09 06 048 2905		
	32		09 06 032 2905		
	32		09 06 032 2941		
Board drillings Mounting side					
Interface connector I with wrap posts ¹⁾ 1 x 1 mm	without nut		09 06 048 2903		
	with nut		09 06 048 2963		
	without nut		09 06 032 2903		
	with nut		09 06 032 2963		
Panel cut out					

* Acc. to IEC 60 603-2, performance level 2 on request
¹⁾ With shroud coding, see also page 02.41

Number of contacts

48

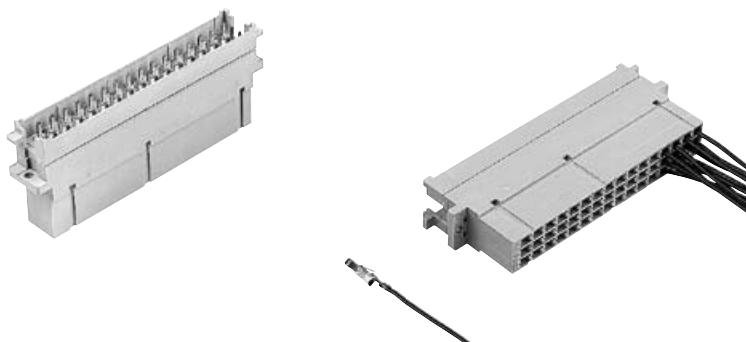

Interface connector I

Identification	Number of contacts	Part No.	Drawing	Dimensions in mm
----------------	--------------------	----------	---------	------------------

Interface connector I utilising female crimp contacts¹⁾

Order crimp contacts separately see page 02.29

48

Performance level 1 acc. to IEC 60 603-2

09 06 048 2906

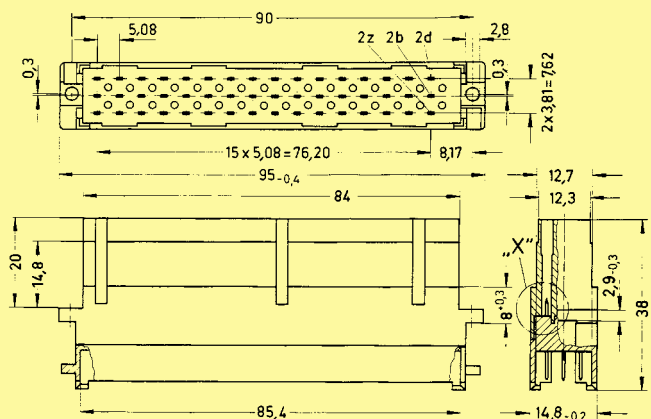

Contact arrangement View from termination side

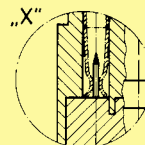
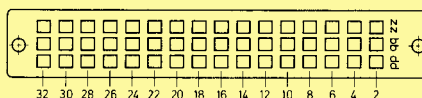

Shell housing see chapter 20

Panel cut out

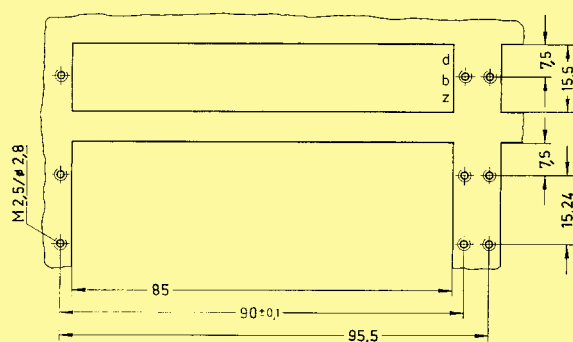

Mounted in shell housing B

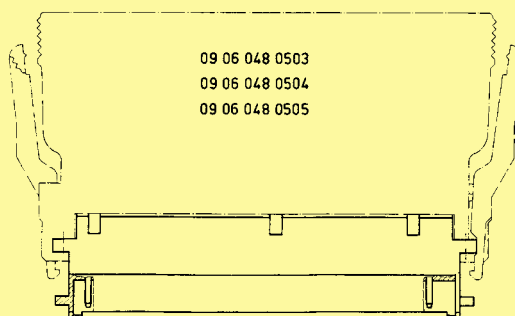

DIN Power 10 6 A

¹⁾ With shroud coding, see also page 02.41

Number of contacts

48

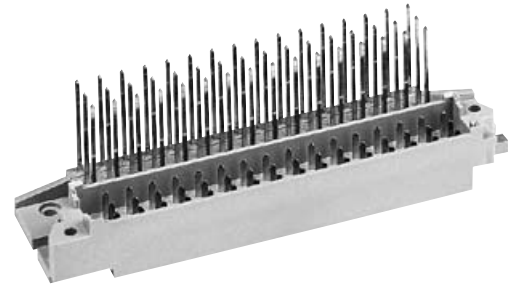

Interface connector U

DIN Power
to 6 A

Identification	Number of contacts	Part No.	Drawing	Dimensions in mm
<p>Interface connector U with wrap posts 1 x 1 mm</p>	<p>48</p>	<p>Performance level 1 acc. to IEC 60 603-2</p> <p>09 06 048 2981</p>	<p>Drawing</p>	
<p>Mounting example</p>				

Number of contacts

max. 48

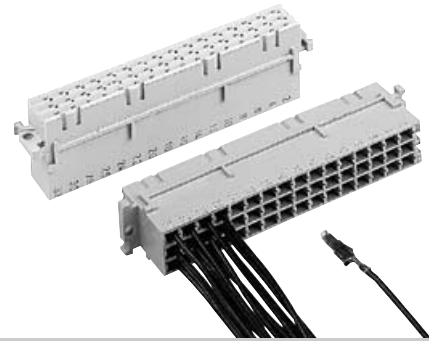

Female connectors

Identification	Number of contacts	Part No.	Drawing	Dimensions in mm
Female connector for crimp contacts ¹⁾ Order contacts separately	48	09 06 248 3201	<p>Contact arrangement View from termination side</p>	
Shell housing see chapter 20				

DIN Power 10 6 A

Identification	Identification Wire gauge	Part No.	Performance levels according to IEC 60 603-2. Explanation chapter 00
			2
			1
Female crimp FC contacts			
Bandoliered contacts (approx. 2,500 pieces)	1	09 06 000 6484	09 06 000 6474
	2	09 06 000 6481	09 06 000 6471
	3	09 06 000 6482	09 06 000 6472
Bandoliered contacts (approx. 250 pieces)	1	09 06 000 7484	09 06 000 7474
	2	09 06 000 7481	09 06 000 7471
	3	09 06 000 7482	09 06 000 7472
Individual contacts ²⁾	1	09 06 000 8484	09 06 000 8474
	2	09 06 000 8481	09 06 000 8471
	3	09 06 000 8482	09 06 000 8472
Female contacts with solder lugs ³⁾ (lockable)			09 06 000 6420

	Wire gauge mm ²	AWG	Insulation ø mm	Identification
FC 1	0.09 - 0.25	28 - 24	0.7 - 1.5	<p>Bandoliered contacts</p> <p>Individual contacts</p>
FC 2	0.14 - 0.56	26 - 20	0.8 - 2.0	
FC 3	0.5 - 1.5	20 - 16	1.6 - 2.8	

3.5 + 0.5 mm of insulation is stripped from the wires to be crimped
 Insertion, removal and crimping tools see chapter 30

¹⁾ With shroud coding, see also page 02.41
²⁾ Packaging unit 1,000 pieces
³⁾ Solder contacts must not be used together with shell housing A. Special contact surface: 2 µm gold.

Number of contacts

48, 32

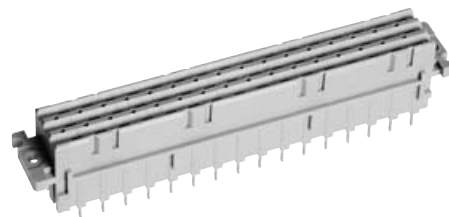

Female connectors

DIN Power
to 6 A

Identification	Number of contacts	Contact arrangement	Part No.	Performance levels according to IEC 60 603-2. Explanation chapter 00		
			3	2	1	
Female connector with solder pins 3.7 mm ¹⁾	48		09 06 248 7848	09 06 248 6848	09 06 248 2848	
	32			09 06 232 6848	09 06 232 2848	
	32			09 06 232 6858	09 06 232 2858	
Female connector with solder pins 4.5 mm ¹⁾	48		09 06 248 7835	09 06 248 6835	09 06 248 2835	
	32			09 06 232 6835	09 06 232 2835	
	32			09 06 232 6845	09 06 232 2845	

Dimensions

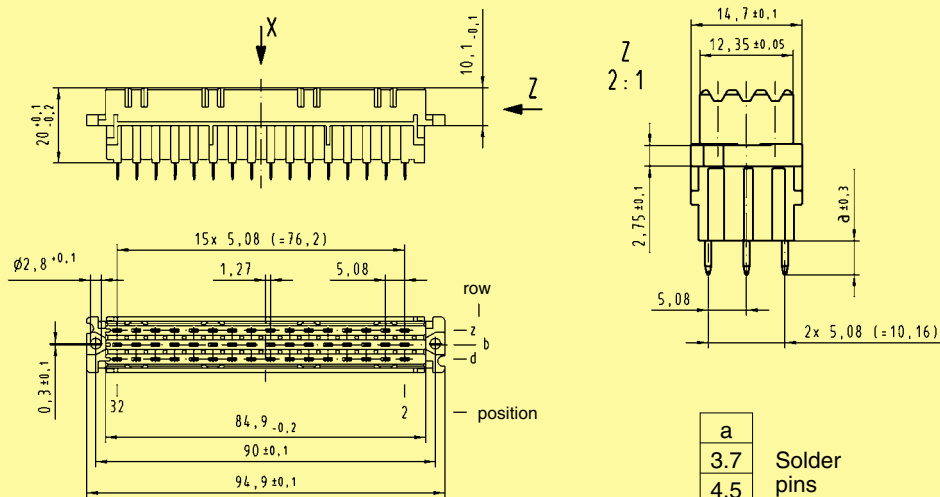

Board drillings Mounting side

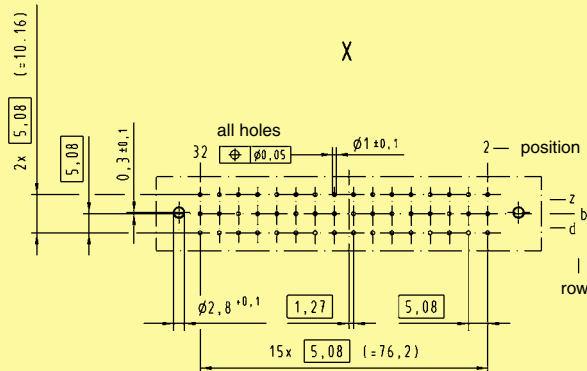

Dimensions in mm

¹⁾ With shroud coding, see also page 02.41

Number of contacts

48, 32

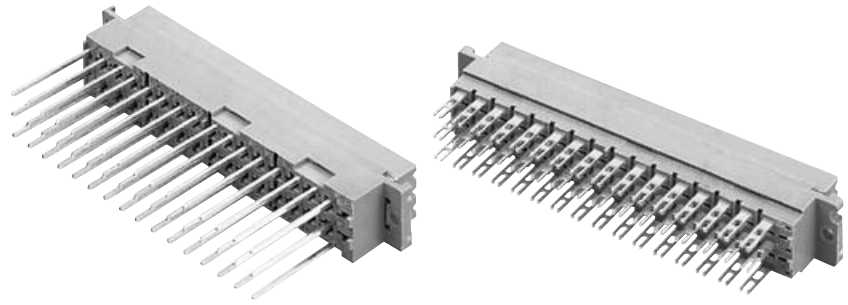

Female connectors

Identification	Number of contacts	Contact arrangement	Part No. Performance levels according to IEC 60 603-2. Explanation chapter 00		
			3	2	1
Female connector with wrap posts 22 mm	48		09 06 248 7821	09 06 248 6821	09 06 248 2821
	32		09 06 232 7821	09 06 232 6821	09 06 232 2821
	32		09 06 232 7831	09 06 232 6831	09 06 232 2831
Female connector with solder lugs open solder lug 	48		09 06 248 7823	09 06 248 6823	09 06 248 2823
	32		09 06 232 7823	09 06 232 6823	09 06 232 2823
	32		09 06 232 7843	09 06 232 6843	09 06 232 2843

DIN Power 10 6 A

Dimensions

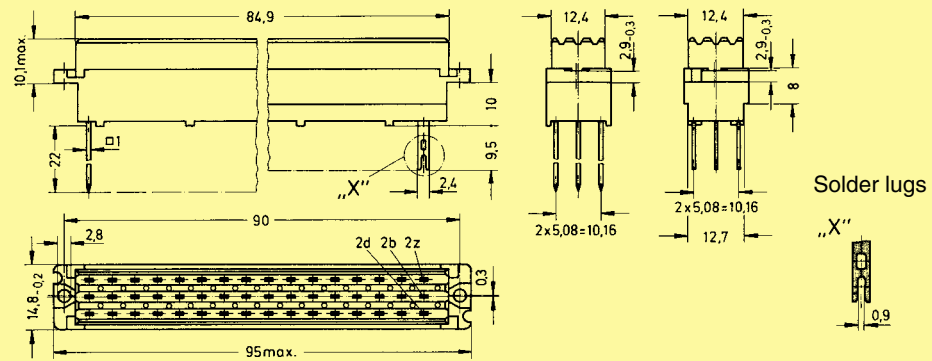

Panel cut out

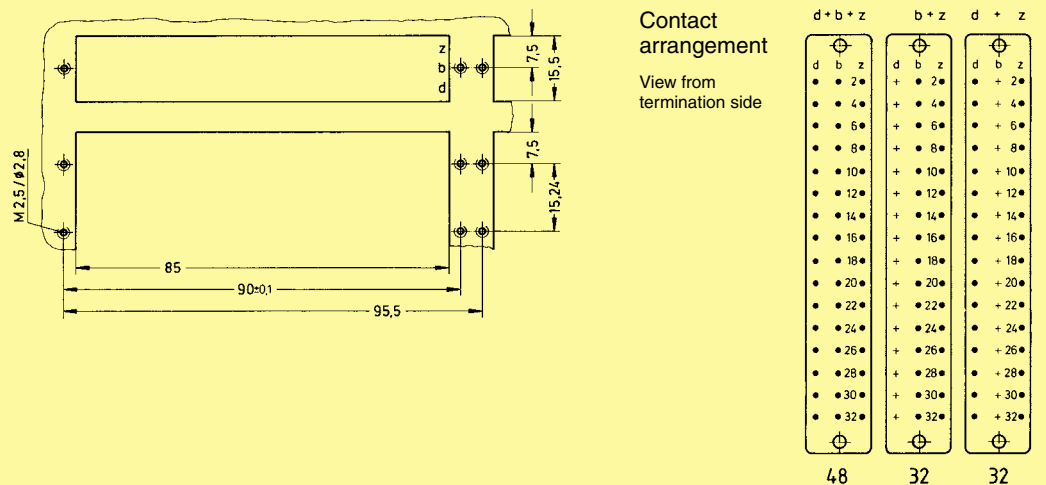

Dimensions in mm

Number of contacts

48, 32

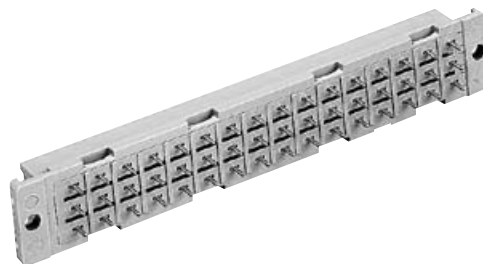

Female connectors

DIN Power
to 6 A

Identification	Number of contacts	Contact arrangement	Part No. Performance levels according to IEC 60 603-2. Explanation chapter 00		
			3	2	1
Female connector "low profile" with solder pins 3.2 mm	48		09 06 248 7833	09 06 248 6833	09 06 248 2833
	32			09 06 232 6833	
	32			09 06 232 6893	
Female connector "low profile" with solder pins 4.5 mm	48		09 06 248 7834	09 06 248 6834	09 06 248 2834
	32			09 06 232 6834	
	32		09 06 232 7894	09 06 232 6894	09 06 232 2894

Female connector with press-in pins

Part Nos. and variants see chapter 04

Dimensions

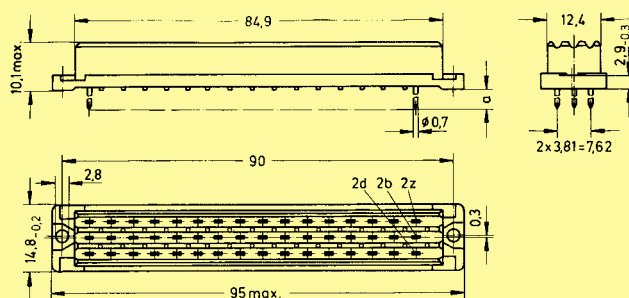

a	Solder pins
3.2	
4.5	

Board drillings

Mounting side

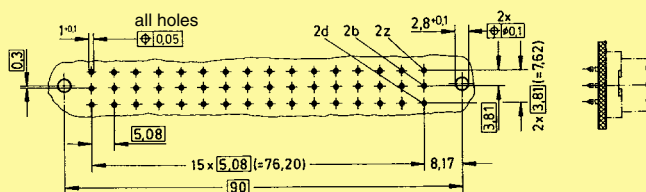

Dimensions in mm

Number of contacts

48, 32

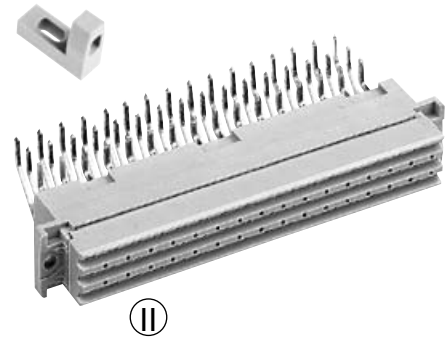
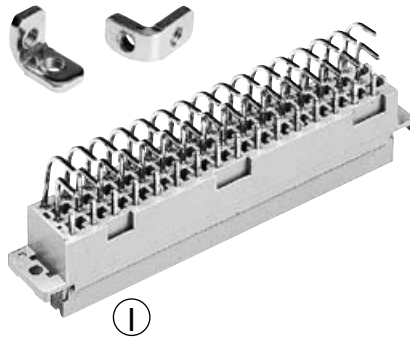

Female connectors

Identification Number of contacts Contact arrangement Part No. Performance levels according to IEC 60 603-2. Explanation chapter 00

Identification	Number of contacts	Contact arrangement	Part No.	Performance levels according to IEC 60 603-2. Explanation chapter 00	
			3	2 1	
Female connector with angled solder pins 1 x 1 mm	48		performance level 3 or special gold plating on request	09 06 248 6826	performance level 1 or special gold plating on request
	32			09 06 232 6826	
	48			09 06 248 6836	
	32			09 06 232 6846	
	32			09 06 232 6836	

Dimensions

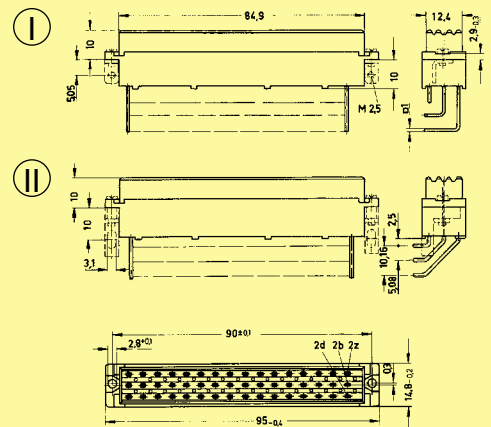

Fixing bracket

¹⁾ Order 2 pieces for one connector

Metal

09 06 000 9912¹⁾

for version

Plastic

09 06 000 9975¹⁾

for version

Board drillings
Mounting side

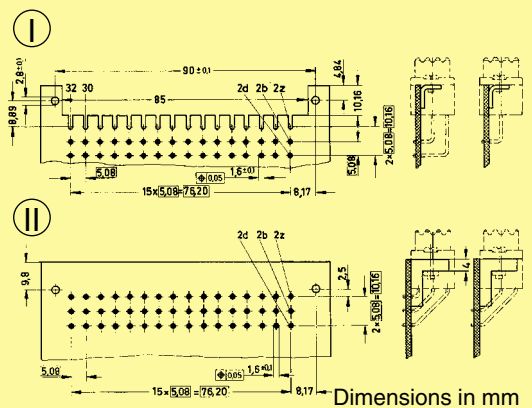

Dimensions in mm

DIN Power 10 6 A