

Chipsmall Limited consists of a professional team with an average of over 10 year of expertise in the distribution of electronic components. Based in Hongkong, we have already established firm and mutual-benefit business relationships with customers from,Europe,America and south Asia,supplying obsolete and hard-to-find components to meet their specific needs.

With the principle of “Quality Parts,Customers Priority,Honest Operation,and Considerate Service”,our business mainly focus on the distribution of electronic components. Line cards we deal with include Microchip,ALPS,ROHM,Xilinx,Pulse,ON,Everlight and Freescale. Main products comprise IC,Modules,Potentiometer,IC Socket,Relay,Connector.Our parts cover such applications as commercial,industrial, and automotives areas.

We are looking forward to setting up business relationship with you and hope to provide you with the best service and solution. Let us make a better world for our industry!



Contact us

Tel: +86-755-8981 8866 Fax: +86-755-8427 6832

Email & Skype: info@chipsmall.com Web: www.chipsmall.com

Address: A1208, Overseas Decoration Building, #122 Zhenhua RD., Futian, Shenzhen, China

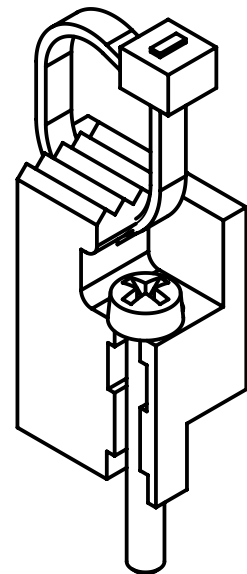
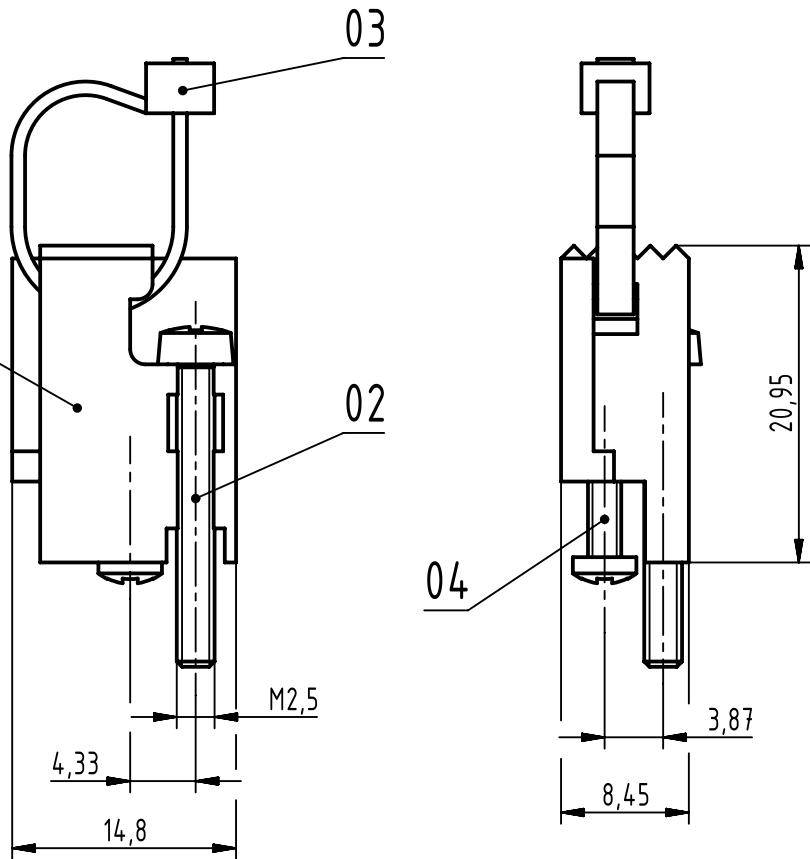

content junction element 0			spare parts	
pos.	number	description	part no.	number
01	2	connection piece		
02	2	pan head screw ISO 7045 M2.5x20-4.8-H	09060009926	1
03	2	cable tie		
04	2	tapping screw ISO 7049 ST2.2x9.5-F-Z		

parts not assembled

	All Dimensions in mm Original Size DIN A4	Scale	Free size tol.		Ref.	
		2:1			Sub. TB 09060009968 Mod. 36101 v. 17.03.11	
All rights reserved Department EC PD - DE	HARTING Electronics GmbH D-32339 Espelkamp	Created by	Inspected by	Standardisation	Date	State
		HAGEMEYERE	TADJE	HOFFMANN	2013-08-21	Final Release
Title					Doc-Key / ECM-Nr.	
DIN Power type F junction element 0					100120354/UGD/002/B 500000065437	
Type	Number	Rev.			Page	
TB	09060009968	B			1/1	