



Chipsmall Limited consists of a professional team with an average of over 10 year of expertise in the distribution of electronic components. Based in Hongkong, we have already established firm and mutual-benefit business relationships with customers from,Europe,America and south Asia,supplying obsolete and hard-to-find components to meet their specific needs.

With the principle of “Quality Parts,Customers Priority,Honest Operation,and Considerate Service”,our business mainly focus on the distribution of electronic components. Line cards we deal with include Microchip,ALPS,ROHM,Xilinx,Pulse,ON,Everlight and Freescale. Main products comprise IC,Modules,Potentiometer,IC Socket,Relay,Connector.Our parts cover such applications as commercial,industrial, and automotives areas.

We are looking forward to setting up business relationship with you and hope to provide you with the best service and solution. Let us make a better world for our industry!



## Contact us

Tel: +86-755-8981 8866 Fax: +86-755-8427 6832

Email & Skype: info@chipsmall.com Web: www.chipsmall.com

Address: A1208, Overseas Decoration Building, #122 Zhenhua RD., Futian, Shenzhen, China



1 2 3 4 5 6

A

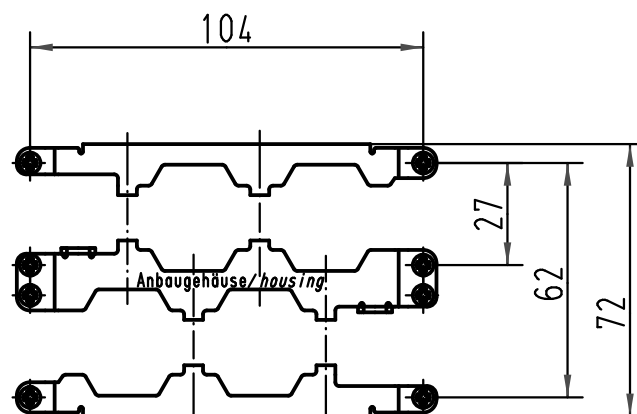

Einbausituation  
Arrangement

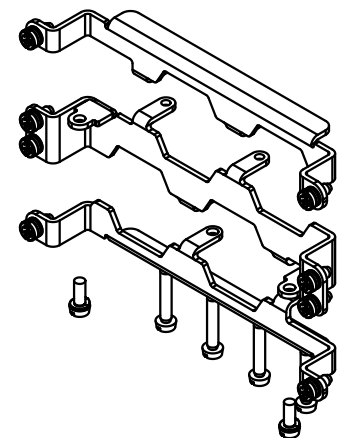
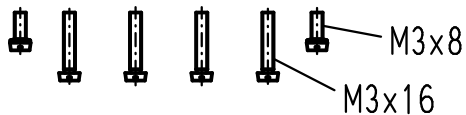

1	2	3	4	⊕
1	2	3	4	⊕
1	2	3	4	⊕
1	2	3	4	⊕

B

C

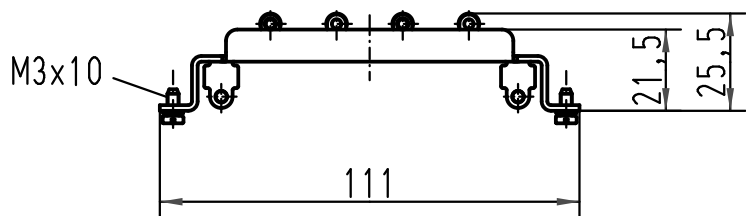

Klebeetiketten zur Kennzeichnung  
der Kontakte und Schutzkontakte  
auf den Halterahmen nach  
DIN EN 61984, 6.2.3

Stickers to mark the contacts  
and PE contacts on the frame acc. to  
DIN EN 61984, 6.2.3

D

ALL Dimensions in mm Original Size DIN A 4			Techn. Character.			Nicht tolerierte Maßel/Free size tolerances			
				Dat.	Name	Maßstab/Scale  1:2	Han 4HC-Halterung Unterteil/ Han 4HC-Frame		
			Detail.	21.04.09	Ho				
			Insp.		Sch				
			Stand.						
A			HARTING Electric GmbH & Co. KG				TB 09 11 000 9955		
Mod.	Dat.	Name	D-32339 Espelkamp						
							Sub. TB 09 11 000 9955 v. 14.12.98		Blatt/ page