



Chipsmall Limited consists of a professional team with an average of over 10 year of expertise in the distribution of electronic components. Based in Hongkong, we have already established firm and mutual-benefit business relationships with customers from,Europe,America and south Asia,supplying obsolete and hard-to-find components to meet their specific needs.

With the principle of "Quality Parts,Customers Priority,Honest Operation,and Considerate Service",our business mainly focus on the distribution of electronic components. Line cards we deal with include Microchip,ALPS,ROHM,Xilinx,Pulse,ON,Everlight and Freescale. Main products comprise IC,Modules,Potentiometer,IC Socket,Relay,Connector.Our parts cover such applications as commercial,industrial, and automotives areas.

We are looking forward to setting up business relationship with you and hope to provide you with the best service and solution. Let us make a better world for our industry!



Contact us

Tel: +86-755-8981 8866 Fax: +86-755-8427 6832

Email & Skype: info@chipsmall.com Web: www.chipsmall.com

Address: A1208, Overseas Decoration Building, #122 Zhenhua RD., Futian, Shenzhen, China



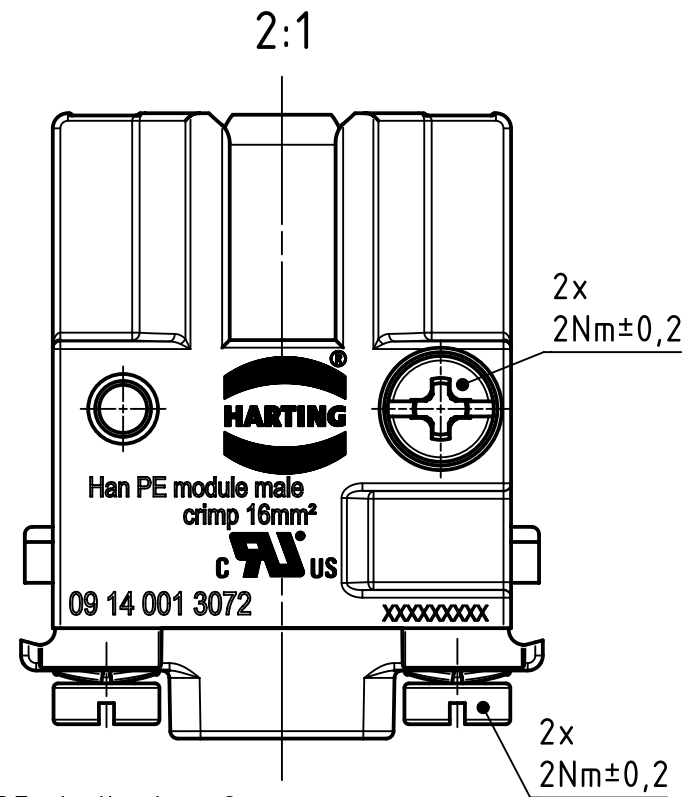
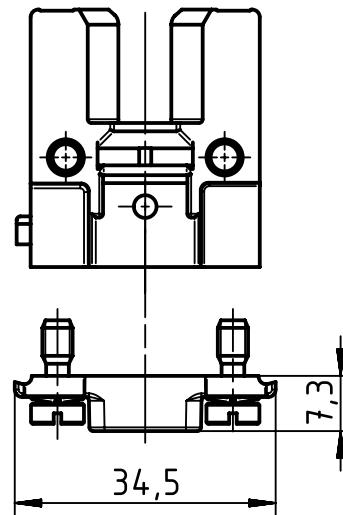
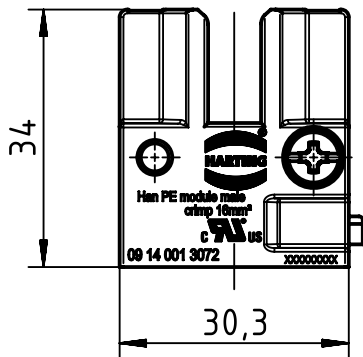

Z (2:1)

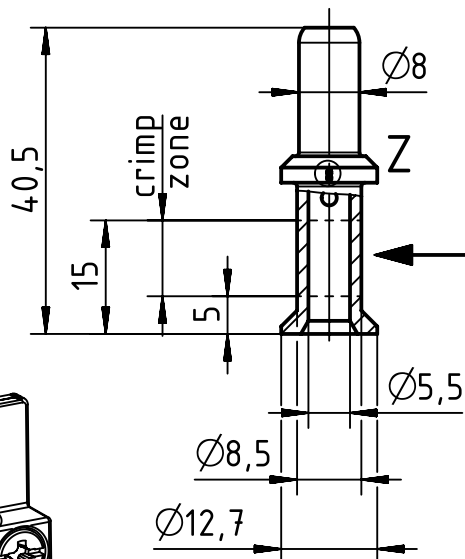
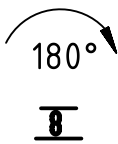

number of crimps

assembly notes see catalog
 crimp zone acc. to DIN EN 46235, indicator 8
 for stranded fine wire acc. to VDE 0295 class 5 / IEC 60228 class 5
 wire gauge: 16mm²
 stripping length: 19mm

All component parts are enclosed separately

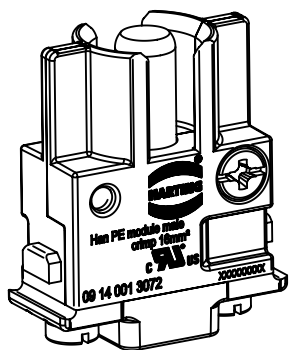

	All Dimensions in mm Original Size DIN A4		Scale 1:1	Free size tol.		Ref.
	All rights reserved Department EL PD - DE		Created by DICK	Inspected by SCHLEGEL	Standardisation TIEMANNA	Date 2016-05-11
HARTING Electric GmbH & Co. KG D-32339 Espelkamp		Title Han PE-module male crimp 16qmm				State Final Release
		Type TB	Number 09 14 001 3072			Doc-Key / ECM-Nr. 100614403/UGD/002/C 500000104304
					Rev. C	Page 1/1