



Chipsmall Limited consists of a professional team with an average of over 10 year of expertise in the distribution of electronic components. Based in Hongkong, we have already established firm and mutual-benefit business relationships with customers from,Europe,America and south Asia,supplying obsolete and hard-to-find components to meet their specific needs.

With the principle of "Quality Parts,Customers Priority,Honest Operation,and Considerate Service",our business mainly focus on the distribution of electronic components. Line cards we deal with include Microchip,ALPS,ROHM,Xilinx,Pulse,ON,Everlight and Freescale. Main products comprise IC,Modules,Potentiometer,IC Socket,Relay,Connector.Our parts cover such applications as commercial,industrial, and automotives areas.

We are looking forward to setting up business relationship with you and hope to provide you with the best service and solution. Let us make a better world for our industry!



Contact us

Tel: +86-755-8981 8866 Fax: +86-755-8427 6832

Email & Skype: info@chipsmall.com Web: www.chipsmall.com

Address: A1208, Overseas Decoration Building, #122 Zhenhua RD., Futian, Shenzhen, China



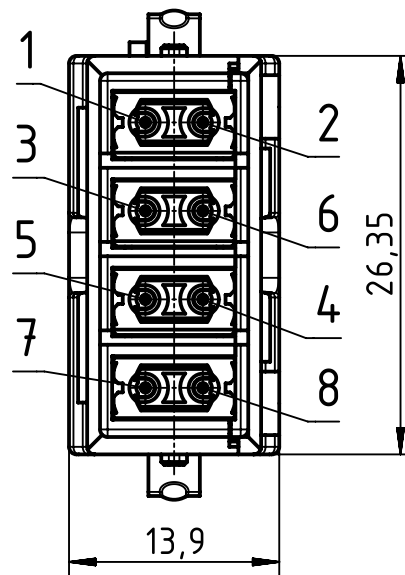
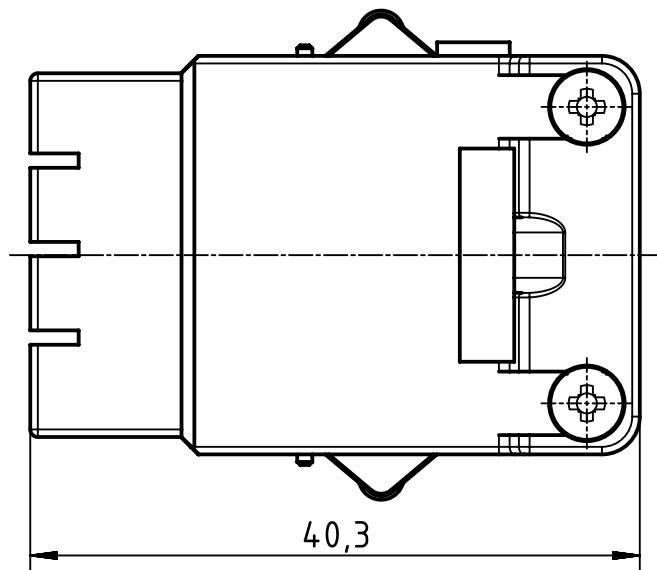

wiring acc. EIA/TIA 568A
view from termination side

green	2•	•1	white/green
orange	6•	•3	white/orange
blue	4•	•5	white/blue
brown	8•	•7	white/brown

wiring acc. EIA/TIA 568B
view from termination side

orange	2•	•1	white/orange
green	6•	•3	white/green
blue	4•	•5	white/blue
brown	8•	•7	white/brown

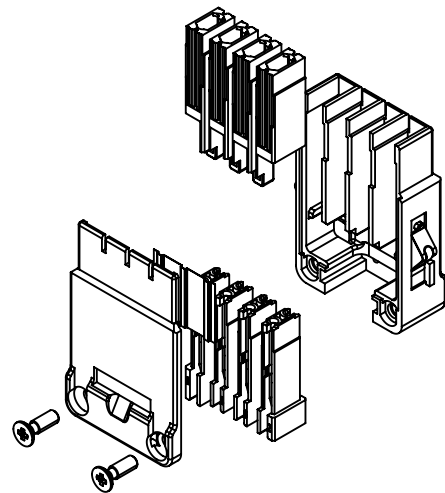

Female contact		
Part number	Wire gauge	
	mm ²	AWG
09930005476	0,13-0,33mm ²	22-26
09930007476	0,09-0,25mm ²	24-28
09930008476	0,25-0,52mm ²	20-24

	All Dimensions in mm Original Size DIN A4		Scale 2:1	Free size tol.		Ref.		
	All rights reserved Department EL PD - DE		Created by RULLKOETTER	Inspected by RIEPE	Standardisation RUETERA	Date 2018-05-09	State Final Release	
HARTING Electric GmbH & Co. KG D-32339 Espelkamp			Title Han Gigabit insert F Cat. 7 (shield-GND)				Doc-Key / ECM-Nr. 100706499/UGD/000/C 500000134981	
			Type TB	Number 09 14 008 3132			Rev. C	Page 1/1