



Chipsmall Limited consists of a professional team with an average of over 10 year of expertise in the distribution of electronic components. Based in Hongkong, we have already established firm and mutual-benefit business relationships with customers from,Europe,America and south Asia,supplying obsolete and hard-to-find components to meet their specific needs.

With the principle of “Quality Parts,Customers Priority,Honest Operation,and Considerate Service”,our business mainly focus on the distribution of electronic components. Line cards we deal with include Microchip,ALPS,ROHM,Xilinx,Pulse,ON,Everlight and Freescale. Main products comprise IC,Modules,Potentiometer,IC Socket,Relay,Connector.Our parts cover such applications as commercial,industrial, and automotives areas.

We are looking forward to setting up business relationship with you and hope to provide you with the best service and solution. Let us make a better world for our industry!



## Contact us

Tel: +86-755-8981 8866 Fax: +86-755-8427 6832

Email & Skype: info@chipsmall.com Web: www.chipsmall.com

Address: A1208, Overseas Decoration Building, #122 Zhenhua RD., Futian, Shenzhen, China



## Features

- Blind mating connector system for drawer systems
- Direct panel mounting without housing
- Very robust design
- Solid pre-leading guid pins and float bushes
- Can be fixed with standard M4 screws

### Notice:



Due to the plastic material used in the docking frame without PE, the panel will need to be grounded separately.

## Technical characteristics

Specifications	DIN EN 60 664-1 DIN EN 61 984
Frames	
Number of modules	2, 3, 4, 6
Material	
Docking Frame	polycarbonate
Float washer	zinc die-cast alloy
Floating tolerance	± 2 mm
Aligning tolerance	± 4 mm
Limiting temperatures	-40 °C ... +125 °C
Flammability acc. to UL 94	V 0
Mechanical working life	≥ 500 mating cycles

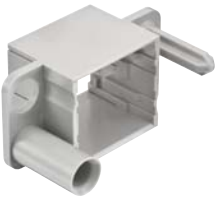
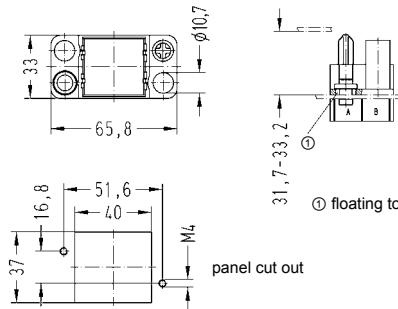
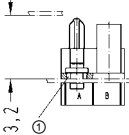

# Han-Modular® Docking Frame

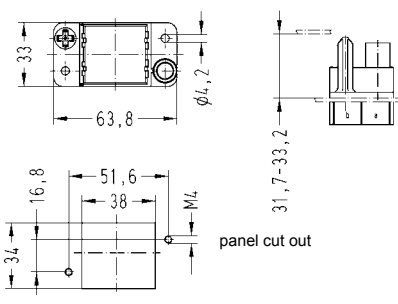
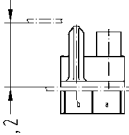
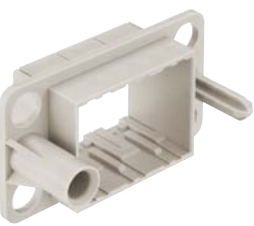
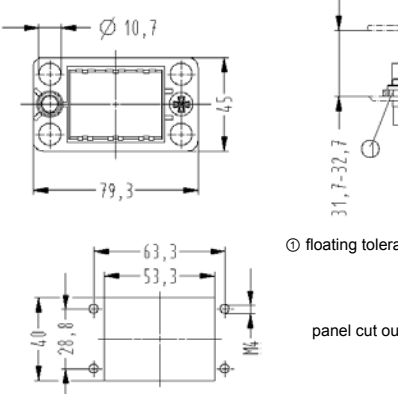
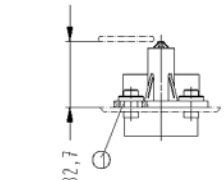
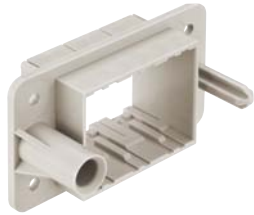
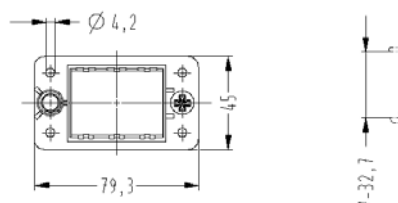
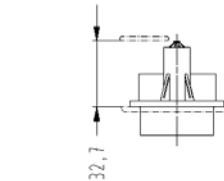

Identification	Float mount A ... F	Fixed a ... f	Drawings	Dimensions in mm
<p>Docking frame for 2 modules</p> 		09 14 006 1701	 <p>panel cut out</p>	 <p>① floating tolerance: ± 2 mm</p>
<p>Docking frame for 2 modules</p> 	09 14 006 1711		 <p>panel cut out</p>	
<p>Docking frame for 3 modules</p> 	09 14 010 1701		 <p>panel cut out</p>	 <p>① floating tolerance: ± 2 mm</p>
<p>Docking frame for 3 modules</p> 		09 14 010 1711		

# Han-Modular® Docking Frame

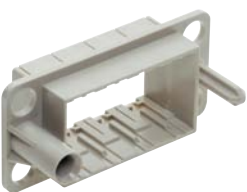
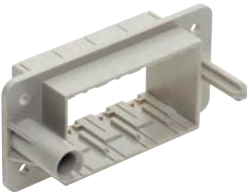
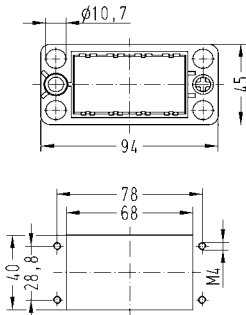
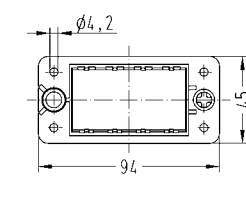
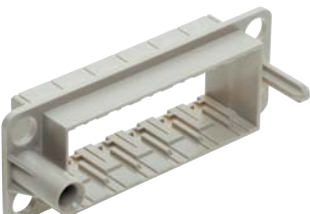
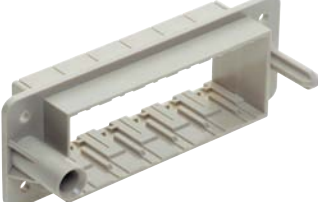
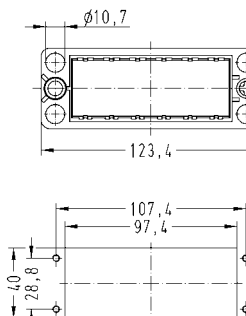
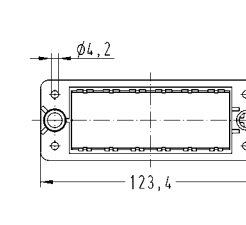

Identification	Float mount A ... F	Fixed a ... f	Drawings	Dimensions in mm
<p>Docking frame for 4 modules</p>  <p>Docking frame for 4 modules</p> 	09 14 016 1701	09 14 016 1711	 	<p>① floating tolerance: ± 2 mm</p> <p>panel cut out</p>
<p>Docking frame for 6 modules</p>  <p>Docking frame for 6 modules</p> 	09 14 024 1701	09 14 024 1711	 	<p>① floating tolerance: ± 2 mm</p>
<p>Float washer</p> <p>to enable the frame to be float mounted using standard M4 fixing screws</p> 	09 14 000 9936		