



Chipsmall Limited consists of a professional team with an average of over 10 year of expertise in the distribution of electronic components. Based in Hongkong, we have already established firm and mutual-benefit business relationships with customers from,Europe,America and south Asia,supplying obsolete and hard-to-find components to meet their specific needs.

With the principle of "Quality Parts,Customers Priority,Honest Operation,and Considerate Service",our business mainly focus on the distribution of electronic components. Line cards we deal with include Microchip,ALPS,ROHM,Xilinx,Pulse,ON,Everlight and Freescale. Main products comprise IC,Modules,Potentiometer,IC Socket,Relay,Connector.Our parts cover such applications as commercial,industrial, and automotives areas.

We are looking forward to setting up business relationship with you and hope to provide you with the best service and solution. Let us make a better world for our industry!



Contact us

Tel: +86-755-8981 8866 Fax: +86-755-8427 6832

Email & Skype: info@chipsmall.com Web: www.chipsmall.com

Address: A1208, Overseas Decoration Building, #122 Zhenhua RD., Futian, Shenzhen, China



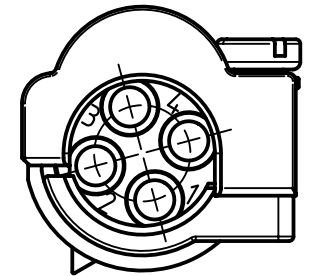
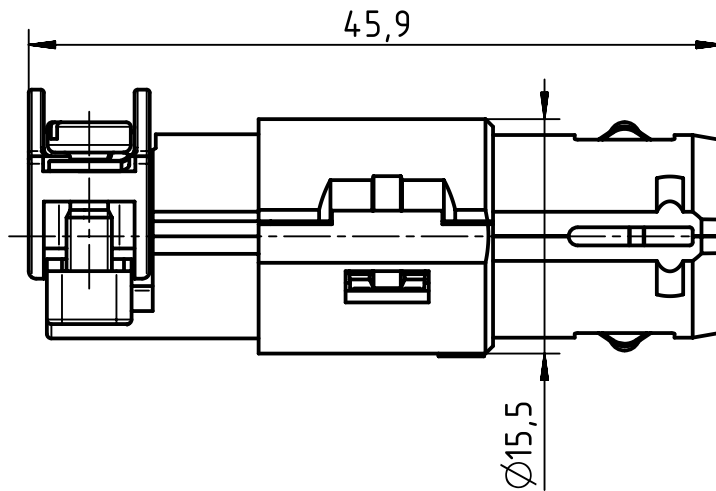
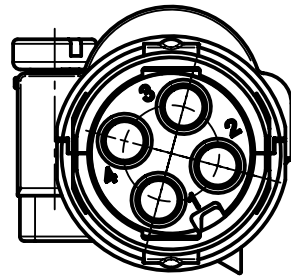
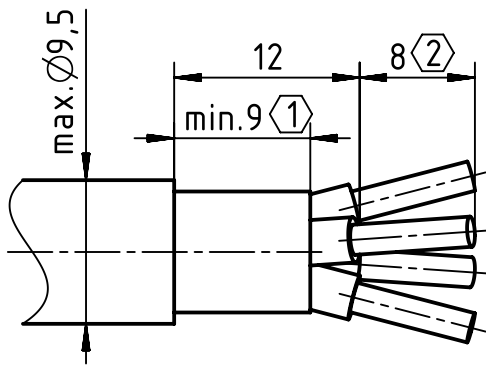

Recommended Ethernet connection

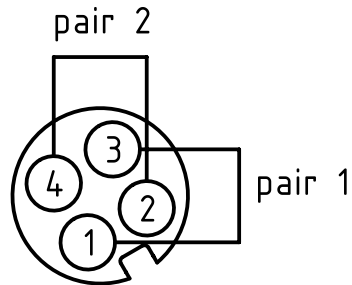

Pin	10BASE-T 100BASE-TX	colour
1	Tx+	white/orange
2	Rx+	white/green
3	Tx-	orange
4	Rx-	green

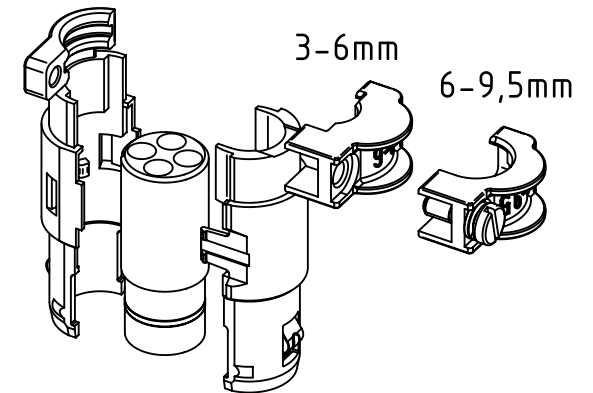

kind of delivery: piece parts

① till screening braid over cable jacket
 recommendation:
 fix end of screening braid
 (more than 9mm) with shrinking tube

② stripping length of a 2,5mm²
 wire gauge is 6mm

	All rights reserved Department EL PD - DE	HARTING Electric GmbH & Co. KG D-32339 Espelkamp	All Dimensions in mm Original Size DIN A4	Scale 2:1 Free size tol.	Created by RULLKOETTER Inspected by GERB Standardisation TIEMANNA	Date 2015-01-14 State Final Release	Ref. Sub.	Doc-Key / ECM-Nr. 100172441/UGD/005/B 500000083549	Rev. B Page 1/1
	Title Han-Quintax contact female, 3-9.5mm Type TB Number 09 15 004 3113								