



Chipsmall Limited consists of a professional team with an average of over 10 year of expertise in the distribution of electronic components. Based in Hongkong, we have already established firm and mutual-benefit business relationships with customers from,Europe,America and south Asia,supplying obsolete and hard-to-find components to meet their specific needs.

With the principle of “Quality Parts,Customers Priority,Honest Operation,and Considerate Service”,our business mainly focus on the distribution of electronic components. Line cards we deal with include Microchip,ALPS,ROHM,Xilinx,Pulse,ON,Everlight and Freescale. Main products comprise IC,Modules,Potentiometer,IC Socket,Relay,Connector.Our parts cover such applications as commercial,industrial, and automotives areas.

We are looking forward to setting up business relationship with you and hope to provide you with the best service and solution. Let us make a better world for our industry!



Contact us

Tel: +86-755-8981 8866 Fax: +86-755-8427 6832

Email & Skype: info@chipsmall.com Web: www.chipsmall.com

Address: A1208, Overseas Decoration Building, #122 Zhenhua RD., Futian, Shenzhen, China



TMC

Thermomagnetic circuit breaker for mounting on a DIN rail

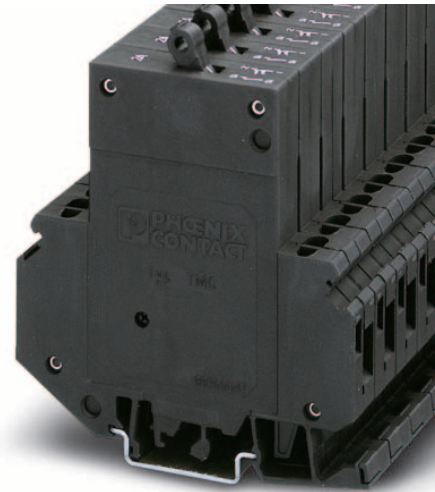

Data sheet
100695_en_03

© PHOENIX CONTACT 2012-03-09

1 Description

Single or multi-position thermomagnetic circuit breaker with lever actuation, DIN rail mounting, trip-free mechanism that cannot be influenced, various characteristic curves, all-pole tripping.

The circuit breakers meet the requirements of circuit breaker standard EN 60934 (IEC 60934): S-type, TM.

Typical areas of application are telecommunications systems, power supply units, industrial switchgear and control systems, and rail vehicles.

The ideal characteristic curve shown here illustrates the curve of the thermomagnetic trigger characteristic. The time-delayed tripping protects the thermal part of the characteristic curve against overload. The magnetic part of the circuit breaker responds without delay to high overload and short-circuit currents and trips within a few milliseconds.

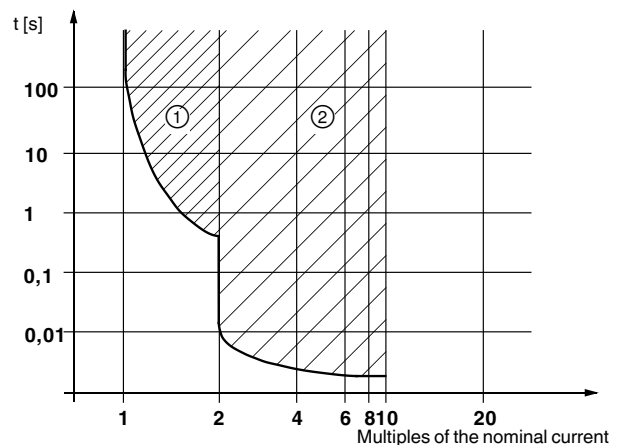

Figure 1 Ideal characteristic curve

- ① Thermal tripping range
- ② Magnetic tripping range



Make sure you always use the latest documentation.
It can be downloaded at www.phoenixcontact.net/catalog.



This data sheet is valid for all products listed on the following page:

2 Ordering data

Thermomagnetic circuit breaker

Description	Type	Order No.	Pcs./Pkt.
Thermomagnetic circuit breaker, with universal foot for mounting on 	TMC... (see order key)		6

Accessories

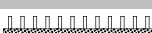
Description	Type	Order No.	Pcs./Pkt.
Insertion bridge , insulated, 80-pos.  (I_{max} : 50 A) (For central supply I_N : 80 A)	EB 80-12	3009338	1
Zack marker strip , 10-section, for labeling the center of the terminal block	ZB 6	See CLIPLINE catalog	
UniCard sheets , for labeling terminal blocks using a Zack marker strip groove, 96-section, can be labeled with BLUEMARK and CMS-P1-PLOTTER, color: white	UC-TM 5	0818108	10
Screwdriver	SZS 0,6X3,5	1205053	10

2.1 Order key

Type	Main current paths	Characteristic curves	Auxiliary contact versions	Nominal current
TMC	1 ≙ Single-pos. 2 ≙ Two-pos. 3 ≙ Three-pos.	F1 ≙ Thermal $1.05 \times I_N \dots 1.4 \times I_N$, magnetic $2 \times I_N \dots 4 \times I_N$ DC (fast-blow), only for DC applications M1 ≙ Thermal $1.05 - 1.4 I_N$, magnetic $6 \times I_N \dots 12 \times I_N$ AC, $7.8 \times I_N \dots 15.6 \times I_N$ DC (medium-blow)	100 ≙ Single-pos.: 1 N/O contact 200 ≙ Single-pos.: 1 N/C contact 120 ≙ Two-pos.: 1 N/O contact, 1 N/C contact 122 ≙ Three-pos.: 1 N/O contact, 2 N/C contacts	0.2 A 2.5 A 0.3 A 3 A 0.4 A 4 A 0.5 A 5 A 0.6 A 6 A 0.8 A 8 A 1 A 10 A 1.2 A 12 A 2A 15A 16A

Ordering example

TMC with 1-pos. main current path, one N/O contact, medium-blow characteristic curve, and a nominal current of 2 A: **TMC 1 M1 100 2A**

3 Technical data

Technical data

Nominal voltage	250 V AC (65 V DC), 3 433 V AC (50/60 Hz)
Nominal current range	0.2 A ... 16 A, see order key
Auxiliary circuit	240 V AC (65 V DC), 1 A
Service life	10,000 cycles with $1 \times I_N$, inductive
Ambient temperature	-30°C ... +60°C (T 60)
Insulation coordination (IEC 60664)	2.5 kV/2, increased insulation in the actuation area
Dielectric strength	
Actuation area	3000 V AC test voltage
Main to auxiliary circuit	3000 V AC test voltage
Position to position	1500 V AC test voltage
Insulation resistance	> 100 MΩ (500 V DC)

Technical data

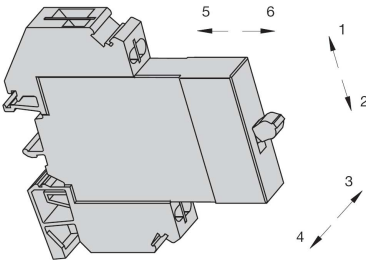
Switching capacity I_{cn}	
TMC...0,2 A ... TMC...5 A	400 A
TMC...6 A ... TMC...16 A	800 A
Characteristic curve F1 and M1	2500 A (at 32 V DC)
Switching capacity I_N (UL 1077)	$I_N = 0.2 A \dots 16 A$
1 and 2-pos.	277 V AC/5000 A
3-pos.	480 V AC/5000 A
1 and 2-pos.	65 V DC/2000 A
Degree of protection (IEC 60529)	
Actuation area	IP30
Connection area	IP20
Vibration resistance	
Characteristic curve F1	3g (57 Hz ... 500 Hz), ± 0.23 mm (10 Hz ... 57 Hz)
Characteristic curve M1	53g (57 Hz ... 500 Hz), ± 0.38 mm (10 Hz ... 57 Hz)
	Test according to IEC 60068-2-6, Test Fc, 10 frequency cycles/axis
Shock resistance	
Characteristic curve F1	25g (11 ms), shock direction 1, 2, 3, 4, 5; 10g (11 ms), shock direction 6
Characteristic curve M1	25g (11 ms), shock direction 1, 2, 3, 4, 5; 20g (11 ms), shock direction 6
	Test according to IEC 60068-2-27, Test Ea
	
Corrosion resistance	96 hours in 5% salt fog
	Test according to IEC 60068-2-11, Text Ka
Humidity test	240 hours in 95% relative humidity
	Test according to IEC 60068-2-78, Text Cab
Weight	60 g per position, approximately

Technical data according to IEC/DIN VDE

Impulse voltage withstand level	4 kV
Pollution degree	3
Auxiliary contact: maximum load current	1 A for 2.5 mm ²
Maximum cross-section with insertion bridge (solid and stranded)	1.5 mm ²
Surge voltage category	III
Insulation material group	I

Connection capacity

	Main contact	Auxiliary contact
Connection capacity		
Solid	0.2 mm ² ... 6 mm ²	0.2 mm ² ... 2.5 mm ²
Stranded	0.2 mm ² ... 4 mm ²	0.2 mm ² ... 1.5 mm ²
Connection capacity (stranded with ferrule)		
Without plastic sleeve	0.25 mm ² ... 4 mm ²	0.25 mm ² ... 2.5 mm ²
With plastic sleeve	0.25 mm ² ... 2.5 mm ²	0.25 mm ² ... 1.5 mm ²
Two conductors with the same cross-section		
Solid and stranded	0.2 mm ² ... 1 mm ²	0.2 mm ² ... 0.75 mm ²
Stranded with ferrule without plastic sleeve	0.2 mm ² ... 1 mm ²	0.2 mm ² ... 0.5 mm ²
Stranded with TWIN ferrule with plastic sleeve	0.5 mm ² ... 2.5 mm ²	0.5 mm ² ... 0.75 mm ²

Connection capacity (continued)	Main contact	Auxiliary contact
Stripping length	12 mm	12 mm
Internal cylindrical gauge (IEC 60947-1)	A 3	A 1
Screw thread	M3	M3
Tightening torque	0.6 Nm ... 0.8 Nm	0.6 Nm ... 0.8 Nm

General data	
Width x length	12.5 mm x 83.5 mm
Height	96 mm
On NS 35/7.5... DIN rail	103.5 mm
On NS 35/15... DIN rail	100.5 mm
On NS 32... DIN rail	
Insulation material	PA-F
Inflammability class according to UL 94	V0
Degree of protection (IEC 60529)	
Actuation area	IP30
Connection area	IP20

Approvals	Nominal voltage	Nominal current range
Test center		
GL, VDE (EN 60934)	3 433 V AC, 250 V AC, 65 V DC	0.1 A ... 32 A
UL, CSA	277 V AC, 277/480 V AC, 3 480 V AC, 65 V DC	0.1 A ... 32 A

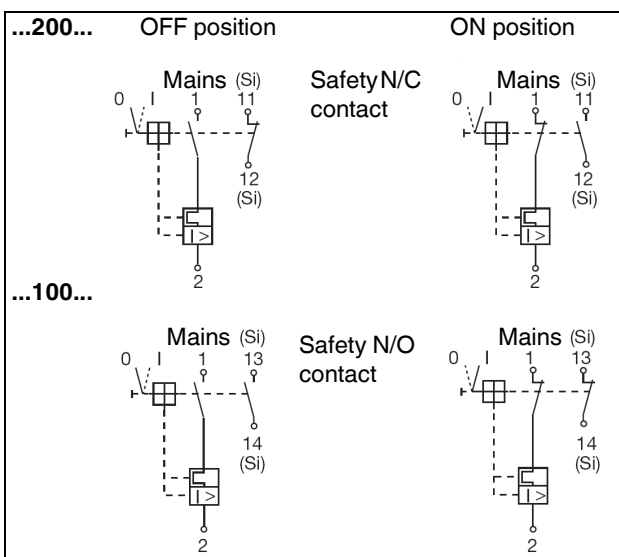

Figure 2 Circuit diagrams

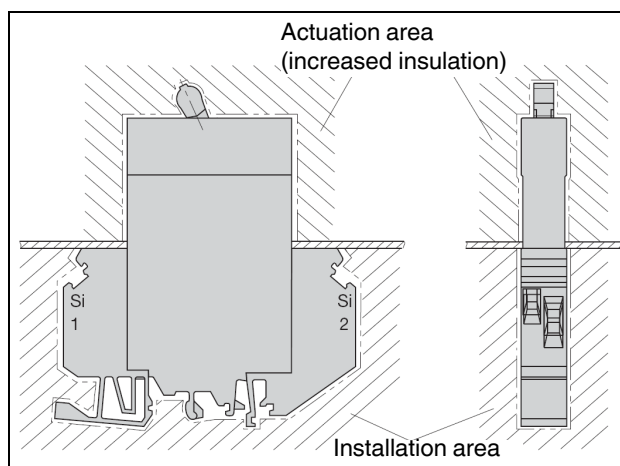

Figure 3 Installation diagram

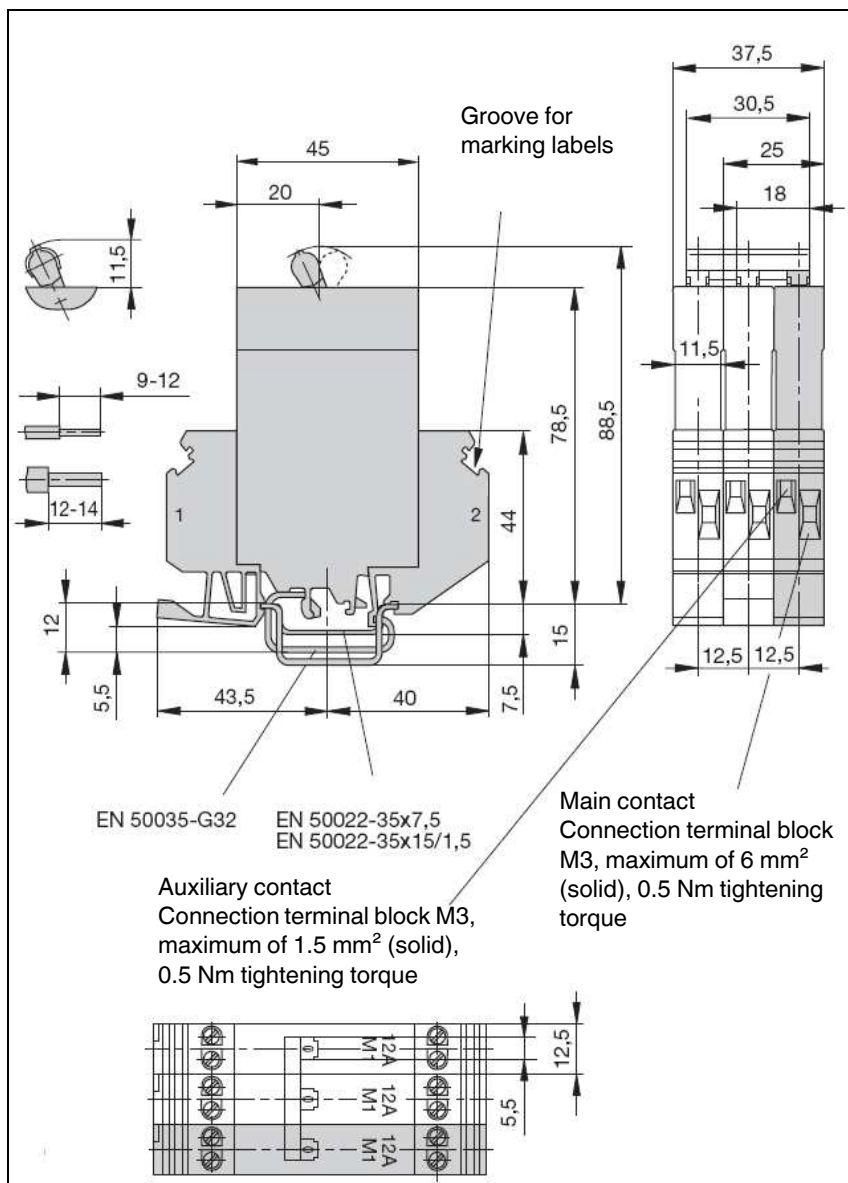

Figure 4 Dimensional drawing (dimensions in mm)

4 Backup fuse



NOTE: Use a backup fuse in combination with the circuit breaker if the maximum switching current can be exceeded in the event of an error.

The table lists the maximum switching current, the relevant internal resistance, and the resulting backup fuse.

Nominal current	NH backup fuse	Internal resistance		Switching capacity according to EN 60934
		F1 (fast-blow) for DC	M1 (medium-blow) for DC/AC	
0.2 A	Any	39.3 Ω	26.1 Ω	400 A
0.3 A	Any	17.5 Ω	11.6 Ω	400 A
0.4 A	Any	9.2 Ω	6.6 Ω	400 A
0.5 A	Any	6.8 Ω	4.1 Ω	400 A
0.6 A	Any	4.2 Ω	3 Ω	400 A
0.8 A	Any	2.8 Ω	1.65 Ω	400 A
1 A	Any	1.6 Ω	1.10 Ω	400 A
1.5 A	25 A	0.78 Ω	0.47 Ω	400 A
2 A	25 A	0.42 Ω	0.28 Ω	400 A
2.5 A	25 A	0.26 Ω	0.183 Ω	400 A
3 A	25 A	0.18 Ω	0.124 Ω	400 A
4 A	25 A	0.12 Ω	0.077 Ω	400 A
5 A	25 A	0.092 Ω	0.063 Ω	400 A
6 A	50 A	0.054 Ω	0.045 Ω	800 A
8 A	50 A	0.025 Ω	≤ 0.02 Ω	800 A
10 A	50 A	0.022 Ω	≤ 0.02 Ω	800 A
12 A	50 A	≤ 0.02 Ω	≤ 0.02 Ω	800 A
16 A	50 A	≤ 0.02 Ω	≤ 0.02 Ω	800 A

5 Trigger characteristics

The thermomagnetic circuit breaker is available in 18 nominal current levels and in single and multi-pos. versions.

The version with the "medium-blow (M1)" trigger characteristic is suitable for AC and DC applications. The "fast-blow (F1)" characteristic version is suitable for DC applications.

The characteristic curves (see page 7) depend on the ambient temperatures. To avoid early or late disconnection, the circuit breaker nominal current must be multiplied by a factor.

Ambient temperature	Multiplication factor
-30°C	0.76
-20°C	0.79
-10°C	0.83
0°C	0.88
10°C	0.93
20°C	1
30°C	1.04
40°C	1.11
50°C	1.19
60°C	1.29

The characteristic curves (see page 7) are also valid for multi-position devices if all positions have an equal load. For multi-position devices and only 1-pos. overload, the thermal tripping limit changes for characteristic curves F1 and M1 to a maximum of $1.7 \times I_N$.

For DC, the magnetic operate values of the curves are around factor 1.3 higher.

Tripping is supported even with high-energy current peaks < 0.003 s.



NOTE: When mounting several circuit breakers in rows, observe the mutual warming effect. When the circuit breakers are loaded simultaneously, a mutual warming effect occurs, which has the same effect as an increase in ambient temperature.

In this case, the nominal current can only be led to 80%. Alternatively, the load current can be increased by a multiplication factor and the circuit breaker dimensioned accordingly.

5.1 Medium-blow (M1): Nominal value 0.2 A ... 6 A

- Lower tripping limit: $1.05 \times I_N$
- Upper tripping limit: $1.4 \times I_N$

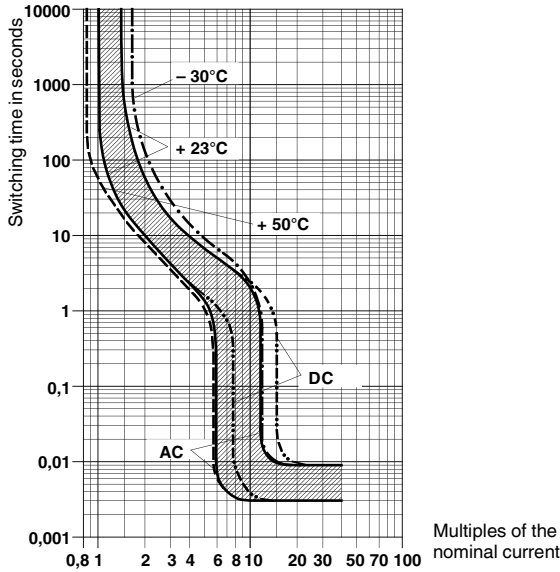

- Lower tripping limit: $1.05 \times I_N$

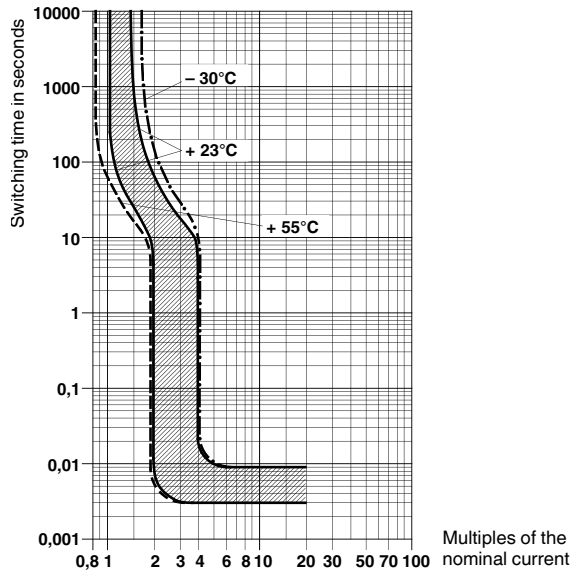

5.2 Medium-blow (M1): Nominal value 8 A ... 16 A

- Lower tripping limit: $1.05 \times I_N$
- Upper tripping limit: $1.4 \times I_N$

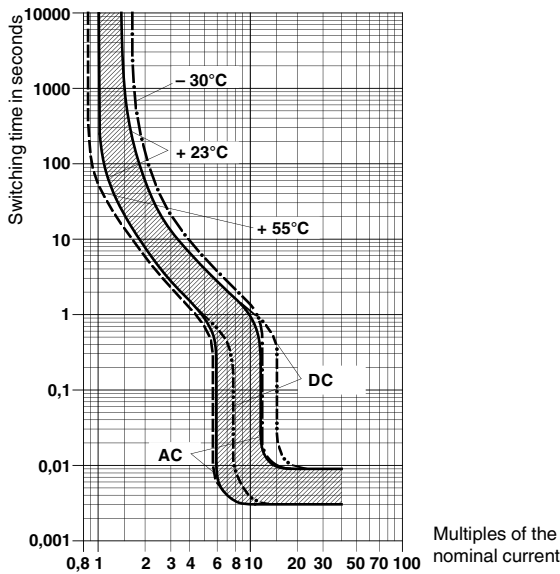

5.3 Fast-blow (F1): Nominal value 0.2 A ... 16 A



Only for DC applications.