



Chipsmall Limited consists of a professional team with an average of over 10 year of expertise in the distribution of electronic components. Based in Hongkong, we have already established firm and mutual-benefit business relationships with customers from,Europe,America and south Asia,supplying obsolete and hard-to-find components to meet their specific needs.

With the principle of “Quality Parts,Customers Priority,Honest Operation,and Considerate Service”,our business mainly focus on the distribution of electronic components. Line cards we deal with include Microchip,ALPS,ROHM,Xilinx,Pulse,ON,Everlight and Freescale. Main products comprise IC,Modules,Potentiometer,IC Socket,Relay,Connector.Our parts cover such applications as commercial,industrial, and automotives areas.

We are looking forward to setting up business relationship with you and hope to provide you with the best service and solution. Let us make a better world for our industry!



## Contact us

Tel: +86-755-8981 8866 Fax: +86-755-8427 6832

Email & Skype: info@chipsmall.com Web: www.chipsmall.com

Address: A1208, Overseas Decoration Building, #122 Zhenhua RD., Futian, Shenzhen, China



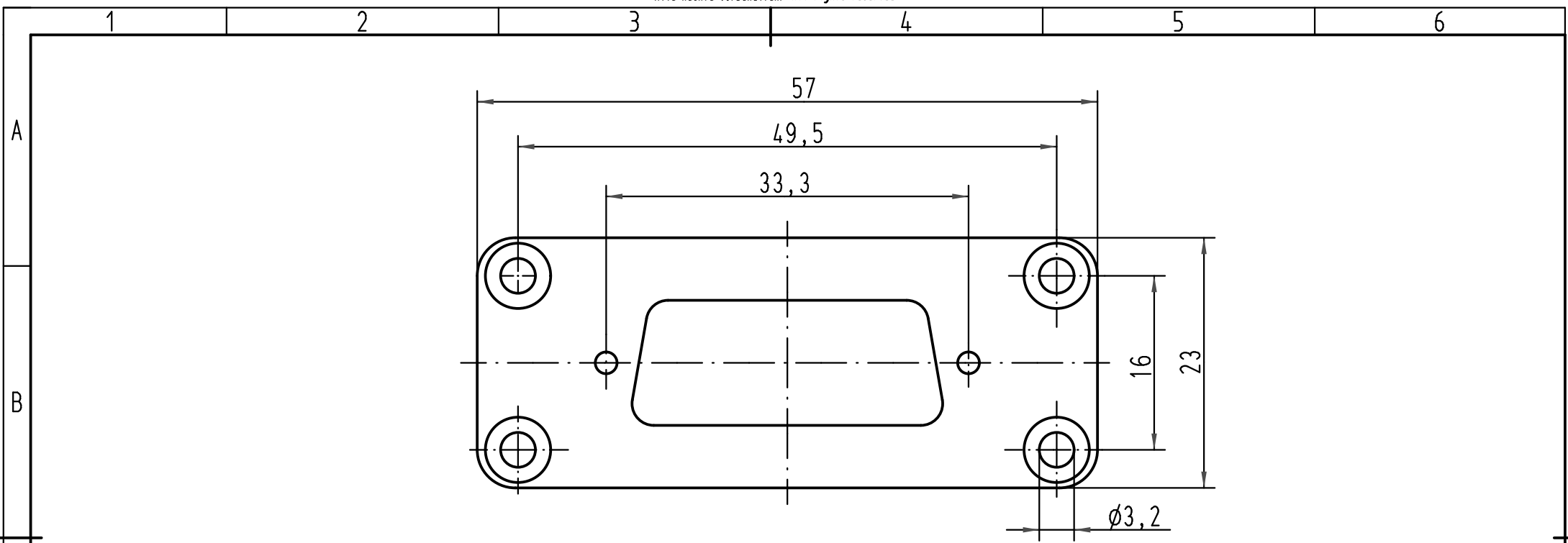

Zum Lieferumfang gehören

- 2 x Schrauben ISO 1481-St2,9x6,5-F
- 4 x Schrauben ISO 1207-M3x10

*belongs to range of delivery*

- 2 x screws ISO 1481-St2,9x6,5-F
- 4 x screws ISO 1207-M3x10

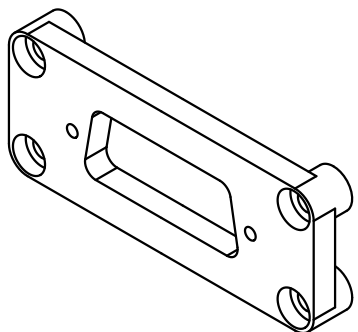

All Dimensions in mm Original Size DIN A 4			Techn. Character.			Nicht tolerierte Maßel/Free size tolerances			
				Dat.	Name	Maßstab/Scale  <b>2:1</b>	<b>Han 10A-D-Sub 15</b> Adapterplatte/ adapterplate		
			Detail.	01.04.99	PL				
			Insp.		SDT				
			Stand.						
413155	27.08.07	Ho	HARTING Electric GmbH & Co. KG				<b>TB 09 20 000 9928</b>		
25625			D-32339 Espelkamp						
Mod.	Dat.	Name							
							Sub. f. TB 09 20 000 992. v. 19.03.93		Blatt/ page