



Chipsmall Limited consists of a professional team with an average of over 10 year of expertise in the distribution of electronic components. Based in Hongkong, we have already established firm and mutual-benefit business relationships with customers from,Europe,America and south Asia,supplying obsolete and hard-to-find components to meet their specific needs.

With the principle of “Quality Parts,Customers Priority,Honest Operation,and Considerate Service”,our business mainly focus on the distribution of electronic components. Line cards we deal with include Microchip,ALPS,ROHM,Xilinx,Pulse,ON,Everlight and Freescale. Main products comprise IC,Modules,Potentiometer,IC Socket,Relay,Connector.Our parts cover such applications as commercial,industrial, and automotives areas.

We are looking forward to setting up business relationship with you and hope to provide you with the best service and solution. Let us make a better world for our industry!



Contact us

Tel: +86-755-8981 8866 Fax: +86-755-8427 6832

Email & Skype: info@chipsmall.com Web: www.chipsmall.com

Address: A1208, Overseas Decoration Building, #122 Zhenhua RD., Futian, Shenzhen, China



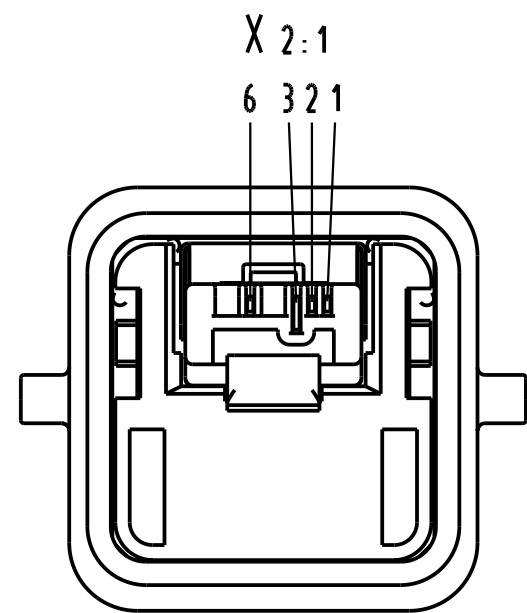
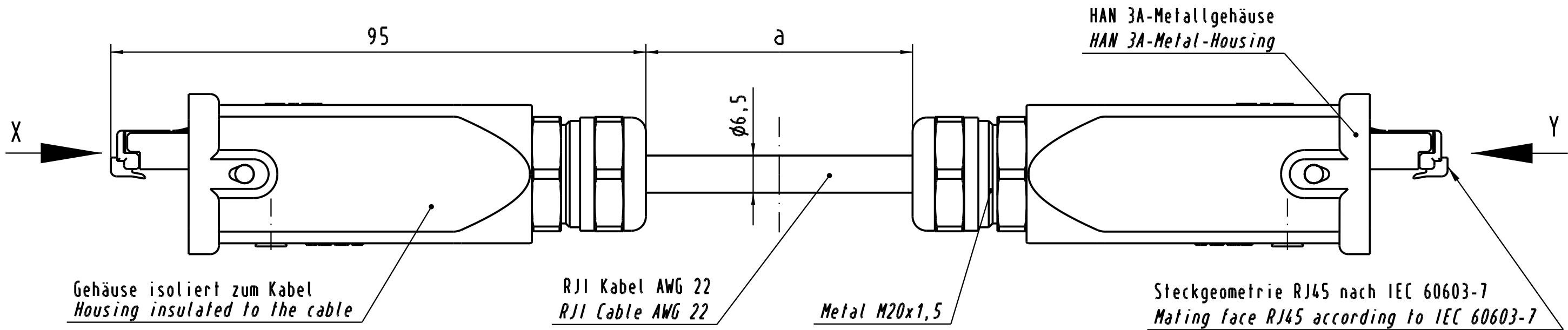

Belegungsplan
Loading-Plan

Schirm Shield

| | | |
|---|---------------|---|
| 1 | Gelb Yellow | 1 |
| 2 | Orange Orange | 2 |
| 3 | Weiß White | 3 |
| 6 | Blau Blue | 6 |

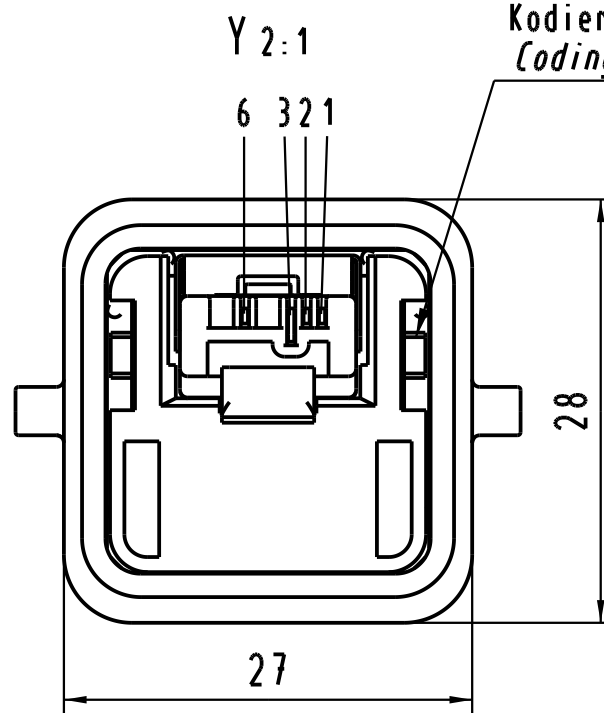

| | | | |
|---------------------------------------|-------------------------|-----------------|---|
| 4xAWG 22/7 schleppfähig/trailing | 09 45 715 0061 | 100 | m |
| 4xAWG 22/7 schleppfähig/trailing | 09 45 715 0056 | 50 | m |
| 4xAWG 22/7 schleppfähig/trailing | 09 45 715 0053 | 20 | m |
| 4xAWG 22/7 schleppfähig/trailing | 09 45 715 0051 | 10 | m |
| 4xAWG 22/7 schleppfähig/trailing | 09 45 715 0027 | 5 | m |
| 4xAWG 22/7 schleppfähig/trailing | 09 45 715 0025 | 3 | m |
| 4xAWG 22/7 schleppfähig/trailing | 09 45 715 0023 | 1,5 | m |
| 4xAWG 22/7 flexibel/stranded | 09 45 715 1183 | 100 | m |
| 4xAWG 22/7 flexibel/stranded | 09 45 715 1178 | 50 | m |
| 4xAWG 22/7 flexibel/stranded | 09 45 715 1175 | 20 | m |
| 4xAWG 22/7 flexibel/stranded | 09 45 715 1173 | 10 | m |
| 4xAWG 22/7 flexibel/stranded | 09 45 715 1168 | 5 | m |
| 4xAWG 22/7 flexibel/stranded | 09 45 715 1166 | 3 | m |
| 4xAWG 22/7 flexibel/stranded | 09 45 715 1164 | 1,5 | m |
| 4xAWG 22/1 massiv/solid | 09 45 715 1161 | 100 | m |
| 4xAWG 22/1 massiv/solid | 09 45 715 1156 | 50 | m |
| 4xAWG 22/1 massiv/solid | 09 45 715 1153 | 20 | m |
| 4xAWG 22/1 massiv/solid | 09 45 715 1151 | 10 | m |
| 4xAWG 22/1 massiv/solid | 09 45 715 1127 | 5 | m |
| 4xAWG 22/1 massiv/solid | 09 45 715 1125 | 3 | m |
| 4xAWG 22/1 massiv/solid | 09 45 715 1123 | 1,5 | m |
| massiv / flexibel solid / stranded | Bestell-Nr. Part-No. | Maß a Dim. a | |

Übertragungseigenschaften nach
ISO/IEC 11801:2002: Class D
Schutzart: IP67/65
Temperaturbereich: -40°C ... +70°C
Transmission properties in accordance
with ISO/IEC 11801:2002: Class D
Protection level: IP67/65
Temperature range: -40°C ... +70°C

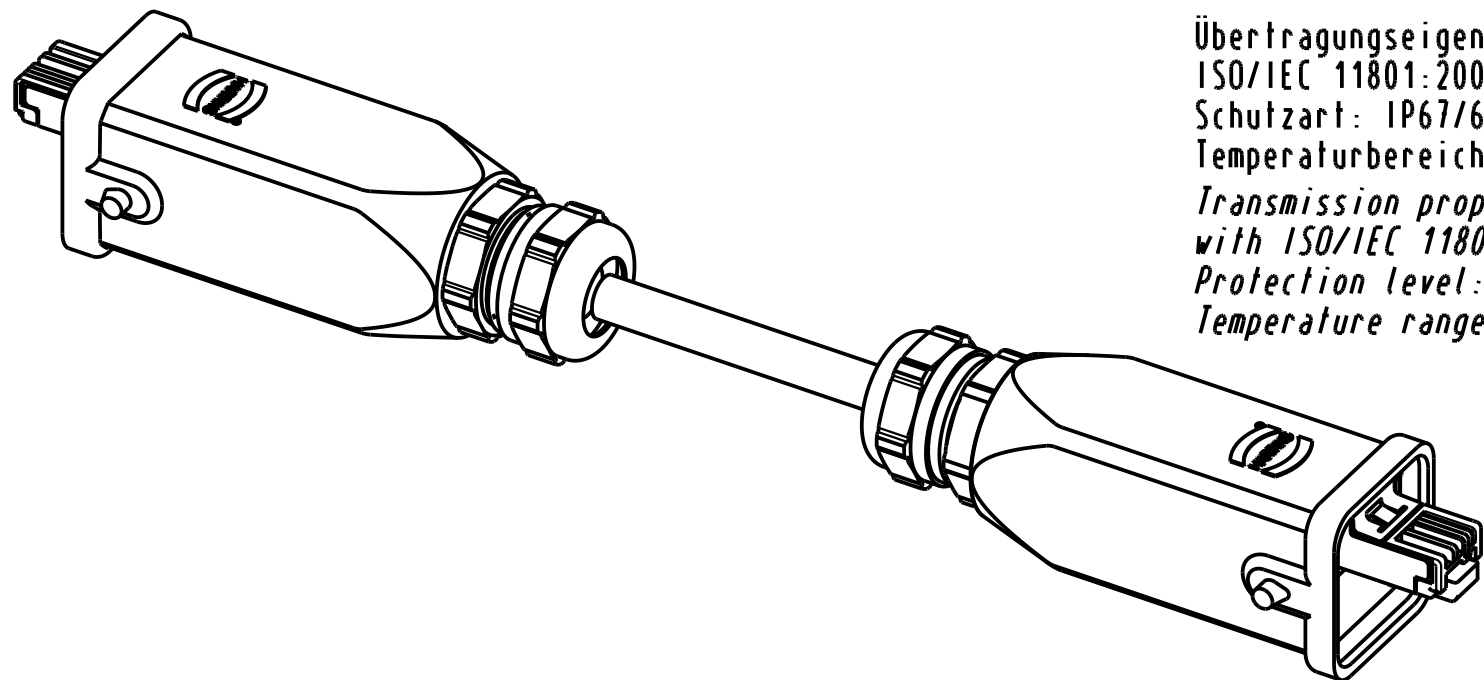

Alle Rechte vorbehalten. All rights reserved

| All Dimensions in mm Original Size DIN A 3 | | | Techn. Character. | | | Nicht tolerierte Maße / Free size tolerances | |
|---|----------|------|-----------------------------------|----------|---------------|---|--|
| Mod. | Dat. | Name | Dat. | Name | Maßstab/Scale | RJI Kabel AWG 22, IP67/65 RJI Cable AWG 22, IP67/65 2x RJ45, Metal, Data 3A | |
| | | | Detail. | 28.05.03 | Wae | | |
| | | | Insp. | 28.05.03 | VSo | | |
| 32429 | 26.11.04 | Wie | Stand. | | | Blatt / page | |
| 32201 | 24.08.04 | Wie | | | | | |
| 32089 | 28.06.04 | Wie | HARTING Electronics GmbH & Co. KG | | | Sub. | |
| 31013 | | | D-32339 ESPELKAMP | | | | |
| | | | | | | | |