



Chipsmall Limited consists of a professional team with an average of over 10 year of expertise in the distribution of electronic components. Based in Hongkong, we have already established firm and mutual-benefit business relationships with customers from,Europe,America and south Asia,supplying obsolete and hard-to-find components to meet their specific needs.

With the principle of “Quality Parts,Customers Priority,Honest Operation,and Considerate Service”,our business mainly focus on the distribution of electronic components. Line cards we deal with include Microchip,ALPS,ROHM,Xilinx,Pulse,ON,Everlight and Freescale. Main products comprise IC,Modules,Potentiometer,IC Socket,Relay,Connector.Our parts cover such applications as commercial,industrial, and automotives areas.

We are looking forward to setting up business relationship with you and hope to provide you with the best service and solution. Let us make a better world for our industry!



Contact us

Tel: +86-755-8981 8866 Fax: +86-755-8427 6832

Email & Skype: info@chipsmall.com Web: www.chipsmall.com

Address: A1208, Overseas Decoration Building, #122 Zhenhua RD., Futian, Shenzhen, China



NOTES:

1. MATERIALS AND FINISHES:

SMA STR PLUG - STAINLESS STEEL, GOLD PLATING
 CABLE - 0.085 CONFORMABLE

2. ELECTRICAL:

A. IMPEDANCE: 50 OHM

3. PACKAGING:

A. QUANTITY: SINGLE PACK
 B. MARKING: BAG TO BE MARKED
 "AMPHENOL RF, 95-902-449-XXX AND DATE CODE".

THIRD ANGLE PROJ.

REVISIONS

REV	DESCRIPTION	DATE	ECO	APPR
A	RELEASE TO MFG	11/16/15	50824	VK

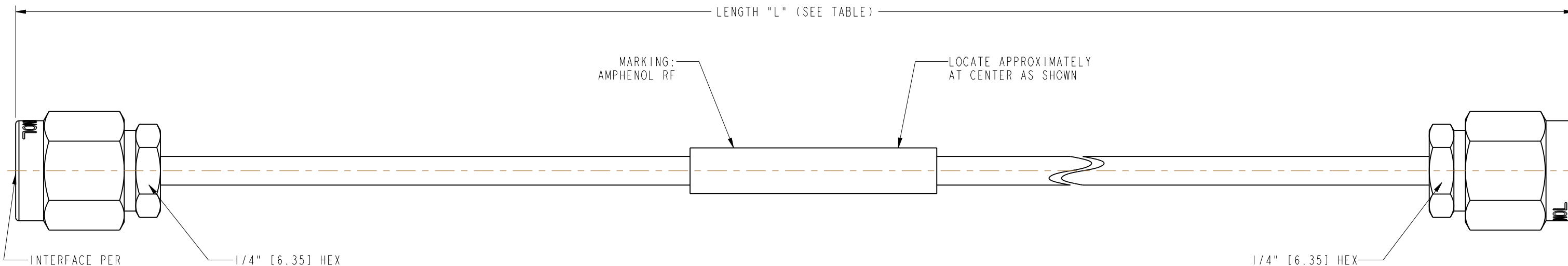
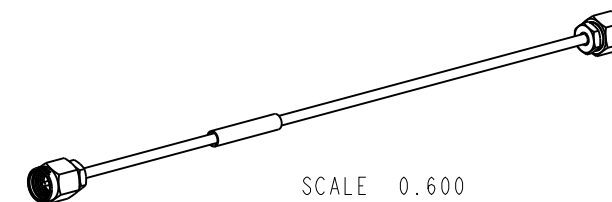

LENGTH TABLE			
PART NUMBER (IMPERIAL)	PART NUMBER (METRIC)	LENGTH "L" IN INCHES [METERS]	INSERTION LOSS MAX (dB)
95-902-449-006	-	6.00 [0.152]	0.65
95-902-449-007	-	7.00 [0.178]	0.75
95-902-449-008	-	8.00 [0.203]	0.80
95-902-449-009	-	9.00 [0.229]	0.90
-	95-902-449M025	9.84 [0.250]	1.00
95-902-449-010	-	10.00 [0.254]	1.00
95-902-449-012	-	12.00 [0.305]	1.20
95-902-449-018	-	18.00 [0.457]	1.70
-	95-902-449M050	19.69 [0.500]	1.85
95-902-449-024	-	24.00 [0.610]	2.25
95-902-449-036	-	36.00 [0.914]	3.30
-	95-902-449M100	39.37 [1.000]	3.60

DESIGN REQUIREMENTS:

- | | |
|--|--|
| <input checked="" type="checkbox"/> FREQUENCY : DC TO 18 GHz | <input checked="" type="checkbox"/> CONTINUITY |
| <input checked="" type="checkbox"/> VSWR : 1.650 MAX. | <input checked="" type="checkbox"/> HI-POT: 500 VRMS |
| <input checked="" type="checkbox"/> INS. LOSS : SEE TABLE | <input type="checkbox"/> OTHER |

CUSTOMER OUTLINE DRAWING

ALL OTHER SHEETS ARE FOR INTERNAL USE ONLY

UNLESS OTHERWISE SPECIFIED, DIMENSIONS ARE IN INCHES AND TOLERANCES ARE: 2 PLACE DECIMAL 3 PLACE DECIMAL ANGLES ±.015 (0.381 mm) ±.005 (0.127 mm) ± 1°	MATERIAL	DRAWN	DATE	TITLE SMA STR PLUG TO SMA STR PLUG WITH ANTI-TORQUE BODY, USING 0.085 CONFORMABLE CABLE, VARIOUS LENGTHS		Amphenol RF www.amphenolrf.com	
	SEE NOTES	VIJI K	15-Oct-15				
NOTICE - These drawings, specifications, or other data (1) are, and remain the property of Amphenol corp. (2) must be returned upon request; and (3) are confidential and not to be disclosed to any person other than those to whom they are given by Amphenol Corp. the furnishing of these drawings, specifications, or other data by Amphenol Corp., or to any other person to anyone for any purpose is not to be regarded by implication or otherwise in any manner licensing, granting rights to permitting such holder or any other person to manufacture, use or sell any product, process or design, patented or otherwise, that may in any way be related to or disclosed by said drawings, specifications, or other data.	REFERENCE	ENGINEER	DATE	SCALE: 3.3:1.0 SHEET 2 OF 2		DRAWING NO. 95-902-449-XXX ITEM NO. 95-902-449-XXX	
	EAR # 6826	VIJI K	15-Oct-15				
	CONFIGURATION LEVEL: In Work	APPROVED	DATE	REV	DWG SIZE B		PART NO. 95-902-449-XXX
FINISH	K. CAPOZZI	11/9/15	A				