



Chipsmall Limited consists of a professional team with an average of over 10 year of expertise in the distribution of electronic components. Based in Hongkong, we have already established firm and mutual-benefit business relationships with customers from,Europe,America and south Asia,supplying obsolete and hard-to-find components to meet their specific needs.

With the principle of “Quality Parts,Customers Priority,Honest Operation,and Considerate Service”,our business mainly focus on the distribution of electronic components. Line cards we deal with include Microchip,ALPS,ROHM,Xilinx,Pulse,ON,Everlight and Freescale. Main products comprise IC,Modules,Potentiometer,IC Socket,Relay,Connector.Our parts cover such applications as commercial,industrial, and automotives areas.

We are looking forward to setting up business relationship with you and hope to provide you with the best service and solution. Let us make a better world for our industry!



Contact us

Tel: +86-755-8981 8866 Fax: +86-755-8427 6832

Email & Skype: info@chipsmall.com Web: www.chipsmall.com

Address: A1208, Overseas Decoration Building, #122 Zhenhua RD., Futian, Shenzhen, China



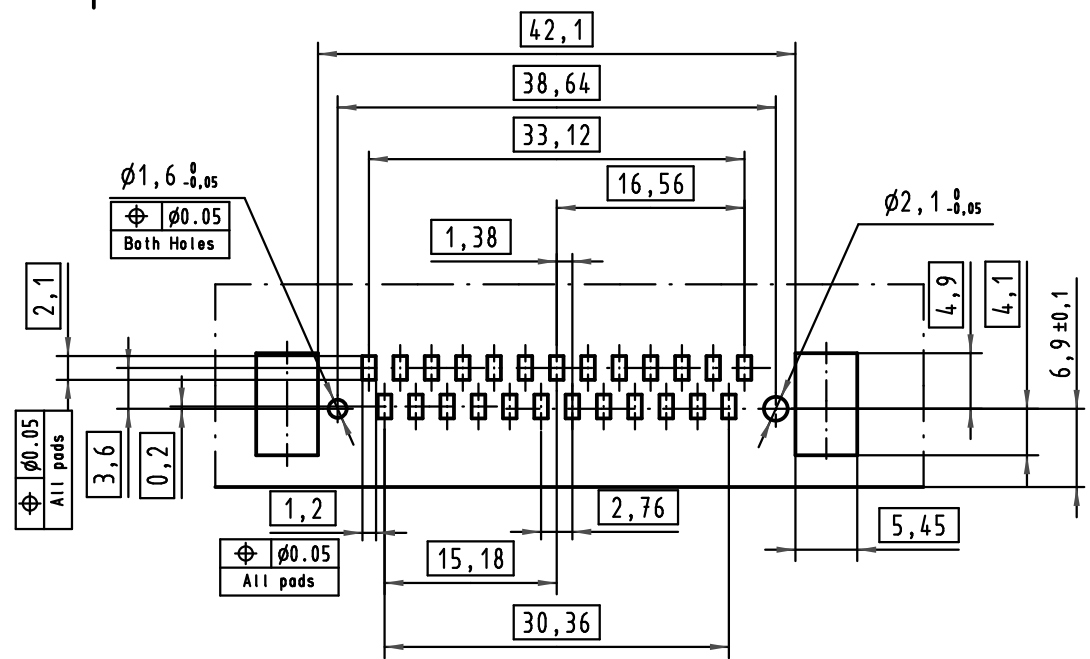
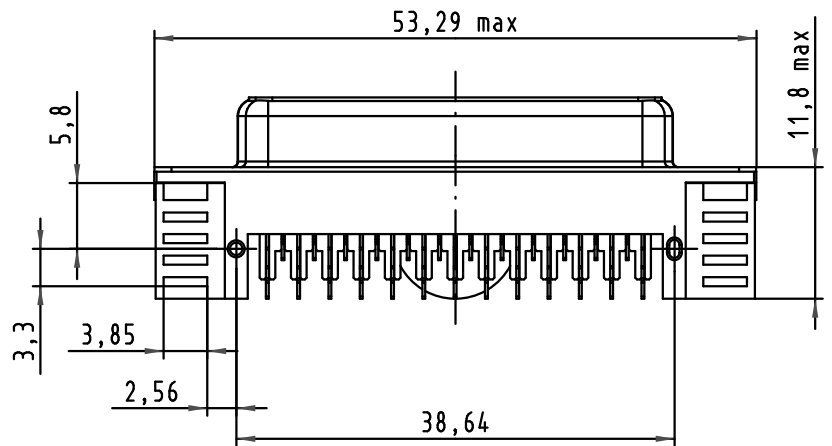
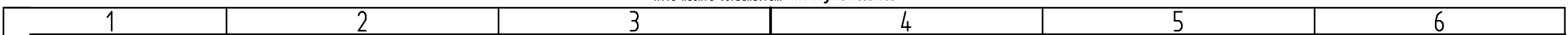

Mating face according to CECC 75301-802

PCB Layout, component side (thickness 1,6mm min.)

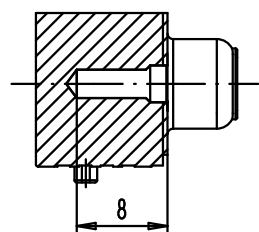
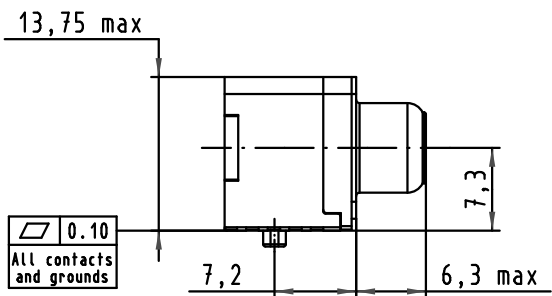
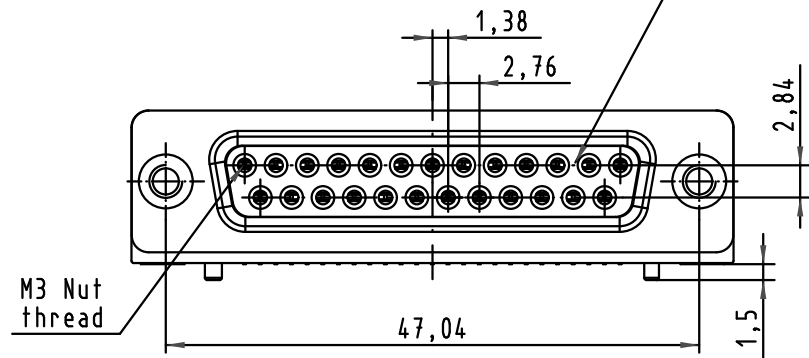

Max. Temperature: 260°C during 10 seconds

D	09553563612.741	1	4-40 UNC	Black Insulator	Reel Packaging (140 connectors) see page 2/2				Dot.	Name	<p>All Dim. in mm Orig. Size DIN A 4</p>	D-SUB SMT Standard Female 25p with die casted grounds and nuts	Maßstab/ Scale 1,5:1	
	09553566612.741	2							Detail.	30Jun2010				ED
	09553567612.741	3							Insp.					
	09553563611.741	1	M3					Stand.						
	09553566611.741	2						EC02316	30Aug2010	ED				HARTING EURL F-95972 Paris
	09553567611.741	3						EC01953	30Jun2010	ED				
Part number	PL	Thread	Index designation	Mod.	Dot.	Name			Sub.		TB 09 55 356 x61x Blatt/ Page 1 / 2			



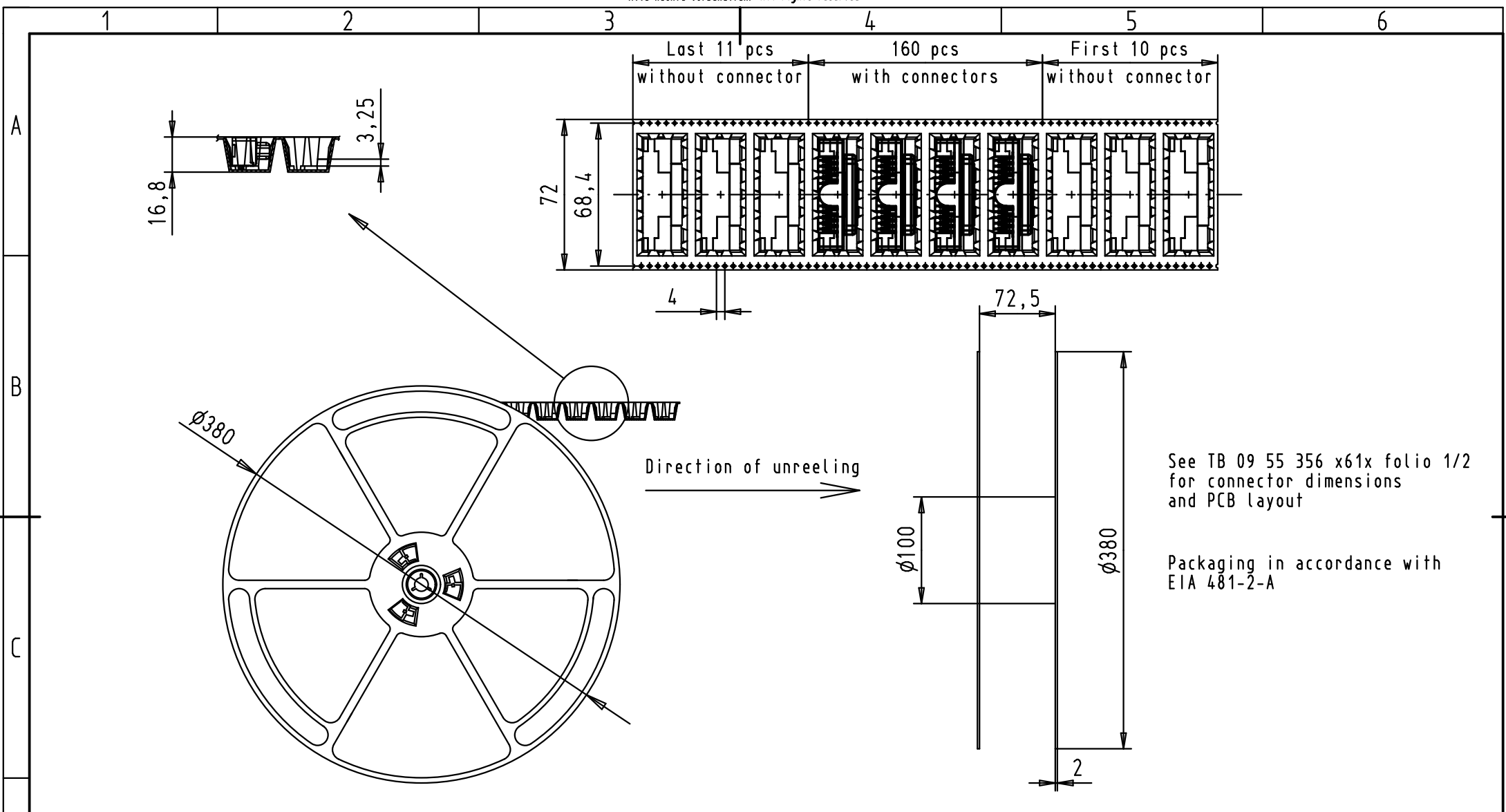

See TB 09 55 356 x61x folio 1/2 for connector dimensions and PCB layout

Packaging in accordance with EIA 481-2-A

D	09553563612.741	1	4-40 UNC	Black Insulator	Reel Packaging (140 connectors)				Dot.	Name	 All Dim. in mm Orig. Size DIN A 4	D-SUB SMT Standard Female 25p with die casted grounds and nuts	Maßstab/ Scale		
	09553566612.741	2							Detail.	30Jun2010				ED	
	09553567612.741	3							Insp.						
	09553563611.741	1	M3						Stand.				TB 09 55 356 x61x	Blatt/ Page 2 / 2	
	09553566611.741	2							EC02316	30Aug2010	ED				HARTING EURL F-95972 Paris
	09553567611.741	3							EC01953	30Jun2010	ED				
	Part number	PL	Thread		Index designation	Mod.	Dot.	Name			Sub.				