



Chipsmall Limited consists of a professional team with an average of over 10 year of expertise in the distribution of electronic components. Based in Hongkong, we have already established firm and mutual-benefit business relationships with customers from,Europe,America and south Asia,supplying obsolete and hard-to-find components to meet their specific needs.

With the principle of “Quality Parts,Customers Priority,Honest Operation,and Considerate Service”,our business mainly focus on the distribution of electronic components. Line cards we deal with include Microchip,ALPS,ROHM,Xilinx,Pulse,ON,Everlight and Freescale. Main products comprise IC,Modules,Potentiometer,IC Socket,Relay,Connector.Our parts cover such applications as commercial,industrial, and automotives areas.

We are looking forward to setting up business relationship with you and hope to provide you with the best service and solution. Let us make a better world for our industry!



Contact us

Tel: +86-755-8981 8866 Fax: +86-755-8427 6832

Email & Skype: info@chipsmall.com Web: www.chipsmall.com

Address: A1208, Overseas Decoration Building, #122 Zhenhua RD., Futian, Shenzhen, China



This document is the property of Amphenol Corporation and is delivered on the express condition that it is not to be disclosed, reproduced or used, in whole or in part, for manufacture or sale by anyone other than Amphenol Corporation without its prior consent, and that no right is granted to disclose or to use any information in this document.

** THIS PRODUCT DIDN'T HAVE ENVIRONMENT- RELATED SUBSTANCES PER MATERIALS SPECIFICATION #MS-S001, LEVEL 1. WHEN THE TIME SET SCHEDULE OF LEVEL 2 IS EXPIRY, THE SUBSTANCES SHALL NOT BE CONTAINED WITH THIS PRODUCT.

CUSTOMER DRAWING ORIGINAL

REVISIONS

SYM	ECN No.	DESCRIPTION	DATE	APPROVED
A		RELEASE FOR RoHS	05/04/2005	Raymond Chao

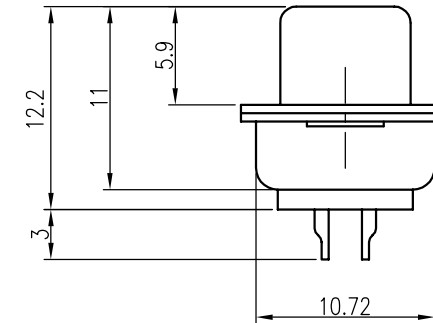
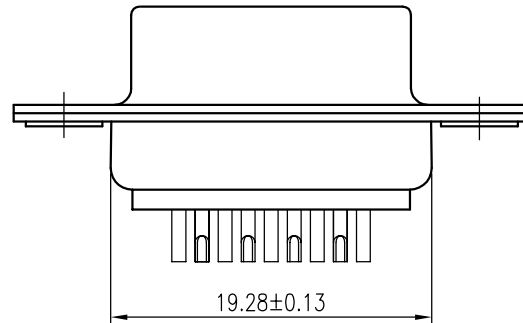
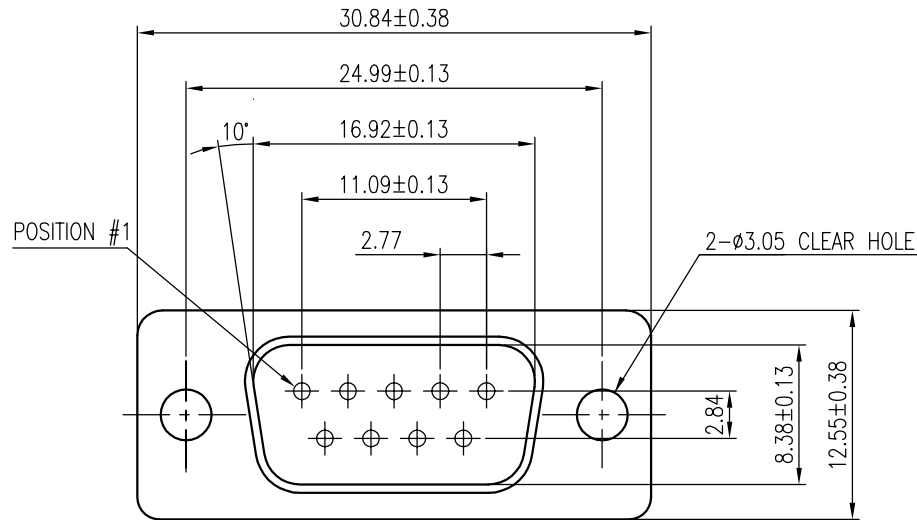

NOTES:

- FRONT & REAR SHELL FINISH: TIN PLATED
- CONTACTS FINISH: FLASH GOLD PLATED
- INSULATOR: PBT, GLASS FIBER FILLED, UL 94V-0, COLOR- BLACK
- THIS PRODUCT DOESN'T CONTAIN ENVIRONMENTAL HAZARDOUS MATERIALS PER MATERIAL SPECIFICATION #MS-S001.

TOLERANCE m/m		APPROVALS	DATE	TITLE		Amphenol®	
x.	±0.30	DRAWN Sondra Sang	05/04/05	G17S SERIES SOLDER-POT TERMINATION PLUG, 9-POSITION		Amphenol Corporation Amphenol Taiwan Corporation	
x.x	±0.25	CHECKED Laura Su	05/04/05				
x.xx	±0.15	APPROVED Ken Lin for	05/04/05				
x.xxx	±0.08			SCALE	N.A.	SHEET	1 OF 1
ANGULAR	±2°			SIZE	PART NO.	DRAWING NO.	REV.
UNLESS OTHERWISE SPECIFIED				A4	G17S 0910 110 EU	DSUB-G17S0910110EU-25	A