



Chipsmall Limited consists of a professional team with an average of over 10 year of expertise in the distribution of electronic components. Based in Hongkong, we have already established firm and mutual-benefit business relationships with customers from,Europe,America and south Asia,supplying obsolete and hard-to-find components to meet their specific needs.

With the principle of “Quality Parts,Customers Priority,Honest Operation,and Considerate Service”,our business mainly focus on the distribution of electronic components. Line cards we deal with include Microchip,ALPS,ROHM,Xilinx,Pulse,ON,Everlight and Freescale. Main products comprise IC,Modules,Potentiometer,IC Socket,Relay,Connector.Our parts cover such applications as commercial,industrial, and automotives areas.

We are looking forward to setting up business relationship with you and hope to provide you with the best service and solution. Let us make a better world for our industry!



Contact us

Tel: +86-755-8981 8866 Fax: +86-755-8427 6832

Email & Skype: info@chipsmall.com Web: www.chipsmall.com

Address: A1208, Overseas Decoration Building, #122 Zhenhua RD., Futian, Shenzhen, China



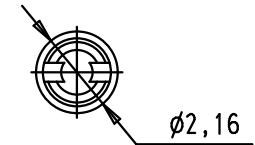
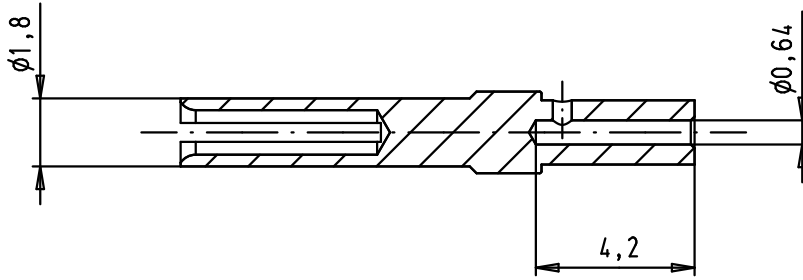

Crimping of AWG 24-28 : hand tool 09 99 000 0501
and locator 09 99 000 0531

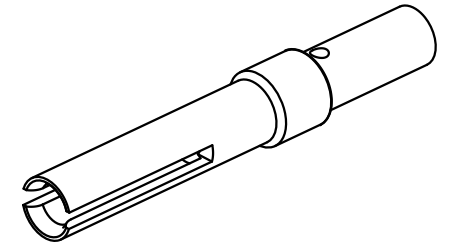
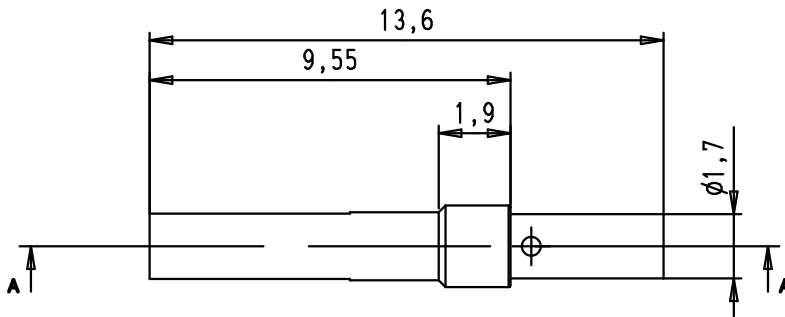

A

5000	09 67 000 7476 580	PL1
	09 67 000 7475 580	S4
100	09 67 000 7476	PL1
	09 67 000 7475	S4
Bulk packaging	Part number	Gold plating (over nickel)

				Det.	Name
				Detail.	12apr2010 LP
				Insp.	
				Stand.	
EC01739	29apr2010	LP			
EC01656	12apr2010	LP			
Mod.	Det.	Name	HARTING EURL F-95972 Paris		



D-Sub	AWG 24-28
female turned crimp contact	
TB09 67 000 747x	
Sub.	

Maßstab/ Scale	5/1
Blatt/ Page	1/1