



Chipsmall Limited consists of a professional team with an average of over 10 year of expertise in the distribution of electronic components. Based in Hongkong, we have already established firm and mutual-benefit business relationships with customers from,Europe,America and south Asia,supplying obsolete and hard-to-find components to meet their specific needs.

With the principle of “Quality Parts,Customers Priority,Honest Operation,and Considerate Service”,our business mainly focus on the distribution of electronic components. Line cards we deal with include Microchip,ALPS,ROHM,Xilinx,Pulse,ON,Everlight and Freescale. Main products comprise IC,Modules,Potentiometer,IC Socket,Relay,Connector.Our parts cover such applications as commercial,industrial, and automotives areas.

We are looking forward to setting up business relationship with you and hope to provide you with the best service and solution. Let us make a better world for our industry!



Contact us

Tel: +86-755-8981 8866 Fax: +86-755-8427 6832

Email & Skype: info@chipsmall.com Web: www.chipsmall.com

Address: A1208, Overseas Decoration Building, #122 Zhenhua RD., Futian, Shenzhen, China



Number of contacts

9-50



Crimp terminal

Identification	No. of contacts	Part number
Male connector Order contacts separately metal shell with dimples	9	09 67 009 5601
	15	09 67 015 5601
	25	09 67 025 5601
	37	09 67 037 5601
	50	09 67 050 5601
Female connector Order contacts separately metal shell	9	09 67 009 4701
	15	09 67 015 4701
	25	09 67 025 4701
	37	09 67 037 4701
	50	09 67 050 4701

Male connector

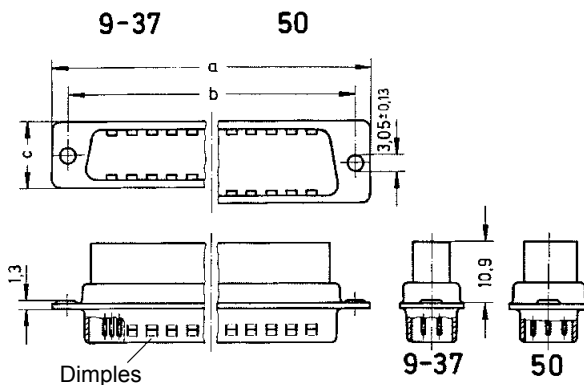

Female connector

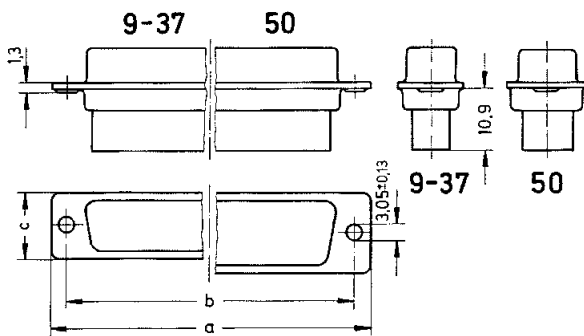

	a	b _{±0.1}	c
9	30.9	25.0	12.5
15	39.2	33.3	12.5
25	53.1	47.0	12.5
37	69.4	63.5	12.5
50	67.0	61.1	15.4

Panel cut out
for front/rear mount
Values are taken from the
CECC 75301-802

see page 05.24

Dimensions in mm