



Chipsmall Limited consists of a professional team with an average of over 10 year of expertise in the distribution of electronic components. Based in Hongkong, we have already established firm and mutual-benefit business relationships with customers from,Europe,America and south Asia,supplying obsolete and hard-to-find components to meet their specific needs.

With the principle of “Quality Parts,Customers Priority,Honest Operation,and Considerate Service”,our business mainly focus on the distribution of electronic components. Line cards we deal with include Microchip,ALPS,ROHM,Xilinx,Pulse,ON,Everlight and Freescale. Main products comprise IC,Modules,Potentiometer,IC Socket,Relay,Connector.Our parts cover such applications as commercial,industrial, and automotives areas.

We are looking forward to setting up business relationship with you and hope to provide you with the best service and solution. Let us make a better world for our industry!



## Contact us

Tel: +86-755-8981 8866 Fax: +86-755-8427 6832

Email & Skype: info@chipsmall.com Web: www.chipsmall.com

Address: A1208, Overseas Decoration Building, #122 Zhenhua RD., Futian, Shenzhen, China



- A. Dual banana jacks for grounding two wrist straps (.162" - .164" ± .002" ID).
- B. Black anodized aluminum angle bracket frame, mounts underneath worksurface.
- C. Dual .155" (4mm) studs for "parking" wrist strap ground cords when not in use.
- D. 10' ground wire. Insulator: PVC, yellow striped green, .100" OD. Conductor: 105 strands each. Approximately 22 gauge with a #10 (.200" ID) ring terminal.
- E. Slotted bracket allows easy installation for screws with a maximum diameter of .175" (4.4mm).
- F. Grounding symbol markings on each banana jack.
- G. Extra #10 (.200" ID) ring terminal for custom installation.
- H. Vinyl boot insulates electrical circuits.

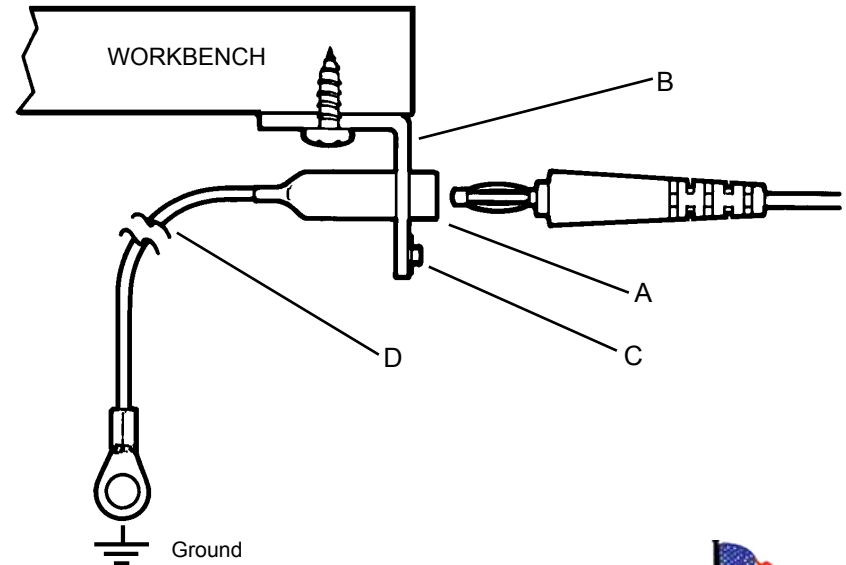
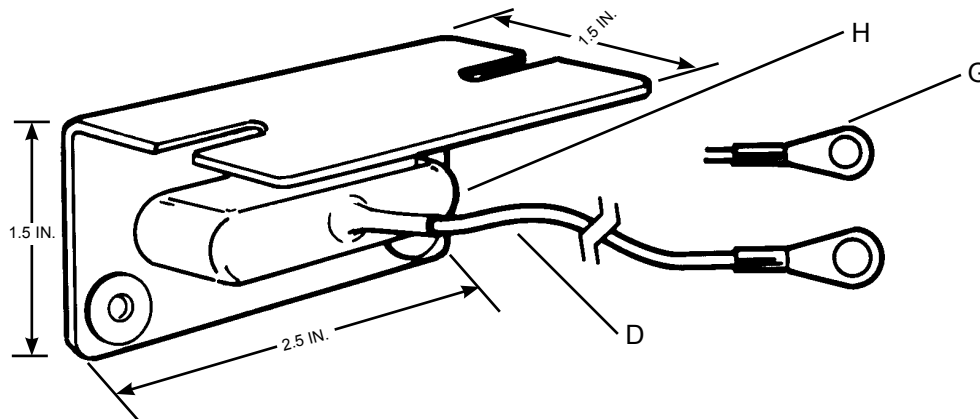
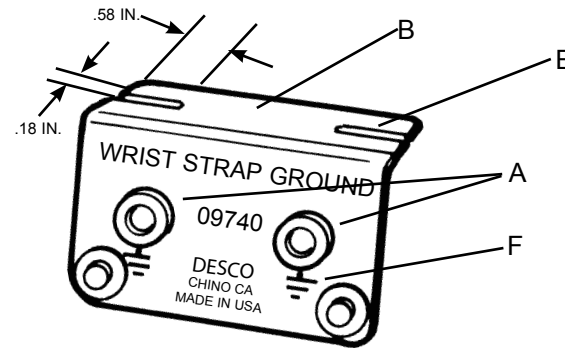

"Grounding / Equipotential Bonding Systems shall be used to ensure that ESDS items, personnel and any other conductors (e.g., mobile equipment) are at the same electrical potential."... "All personnel shall be bonded or electrically connected to the grounding / equipotential bonding system when handling ESDS [ESD sensitive] items." (ANSI/ESDS20.20 section 8.)

"When personnel are seated at ESD protective workstations, they shall be connected to the grounding / equipotential bonding system via a wrist strap system." (ANSI/ESDS20.20-2007 section 8.2)

Specifications and procedures subject to change without notice.



Made in America

### GROUND CORD, DUAL WRIST STRAP, BENCH MOUNT

DESCO WEST: 3651 WALNUT AVE., CHINO, CA 91710 WEB SITE: [Desco.com](http://Desco.com)  
 PHONE (909) 627-8178 FAX (909) 627-7449  
 DESC0 EAST: ONE COLGATE WAY, CANTON, MA 02021-1407  
 PHONE (781) 821-8370 FAX (781) 575-0172

**DRAWING  
NUMBER**  
09740

**DATE:**  
February  
2010

# DESCO