



Chipsmall Limited consists of a professional team with an average of over 10 year of expertise in the distribution of electronic components. Based in Hongkong, we have already established firm and mutual-benefit business relationships with customers from,Europe,America and south Asia,supplying obsolete and hard-to-find components to meet their specific needs.

With the principle of “Quality Parts,Customers Priority,Honest Operation,and Considerate Service”,our business mainly focus on the distribution of electronic components. Line cards we deal with include Microchip,ALPS,ROHM,Xilinx,Pulse,ON,Everlight and Freescale. Main products comprise IC,Modules,Potentiometer,IC Socket,Relay,Connector.Our parts cover such applications as commercial,industrial, and automotives areas.

We are looking forward to setting up business relationship with you and hope to provide you with the best service and solution. Let us make a better world for our industry!



Contact us

Tel: +86-755-8981 8866 Fax: +86-755-8427 6832

Email & Skype: info@chipsmall.com Web: www.chipsmall.com

Address: A1208, Overseas Decoration Building, #122 Zhenhua RD., Futian, Shenzhen, China



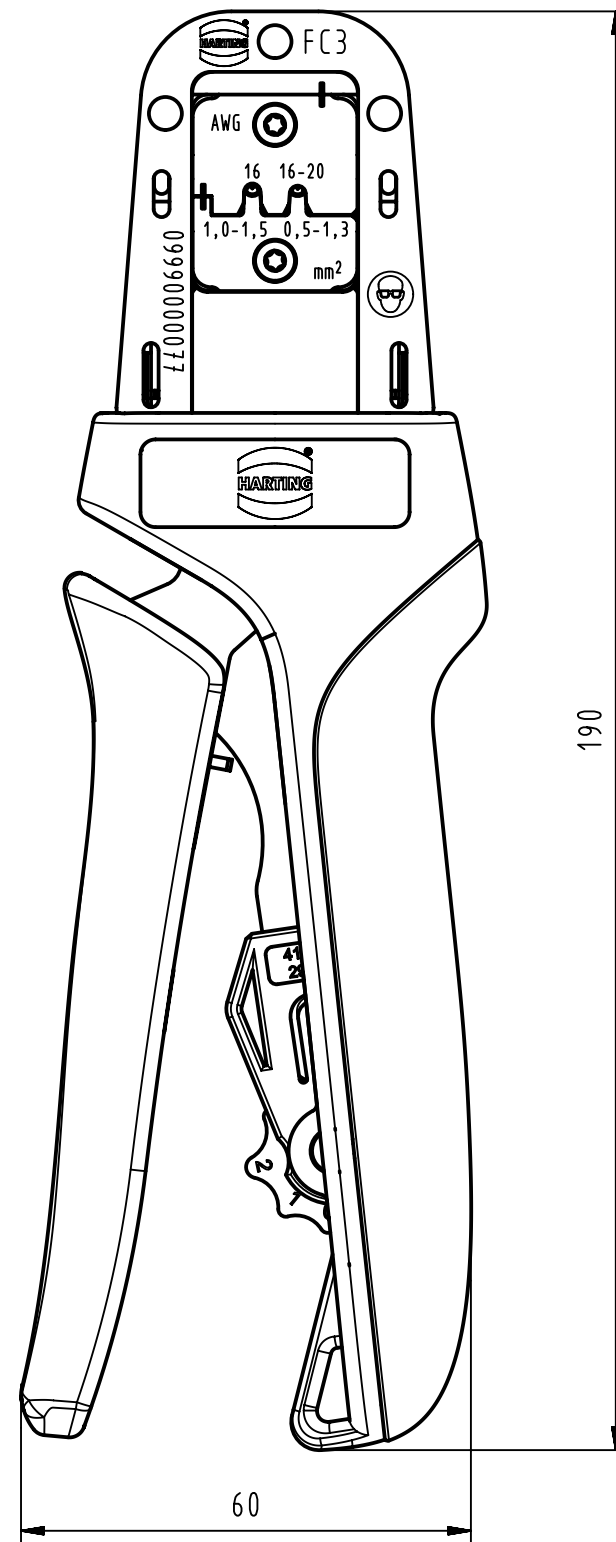
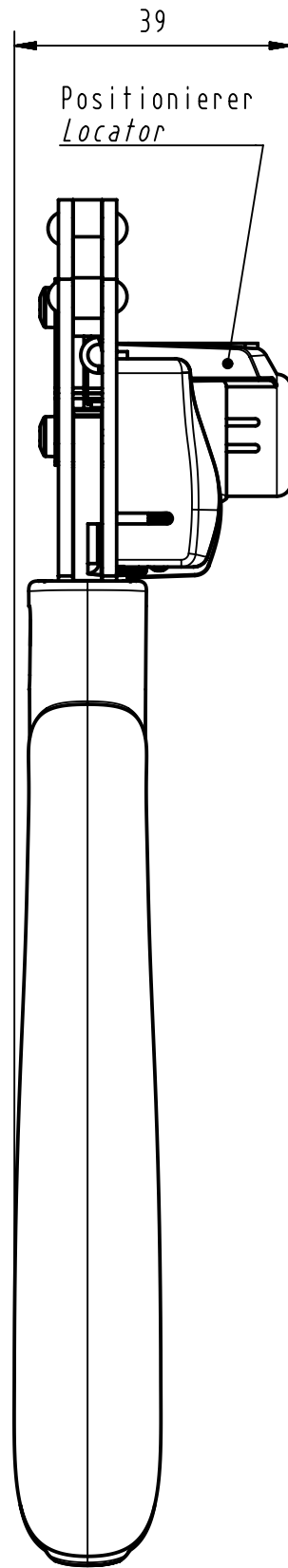
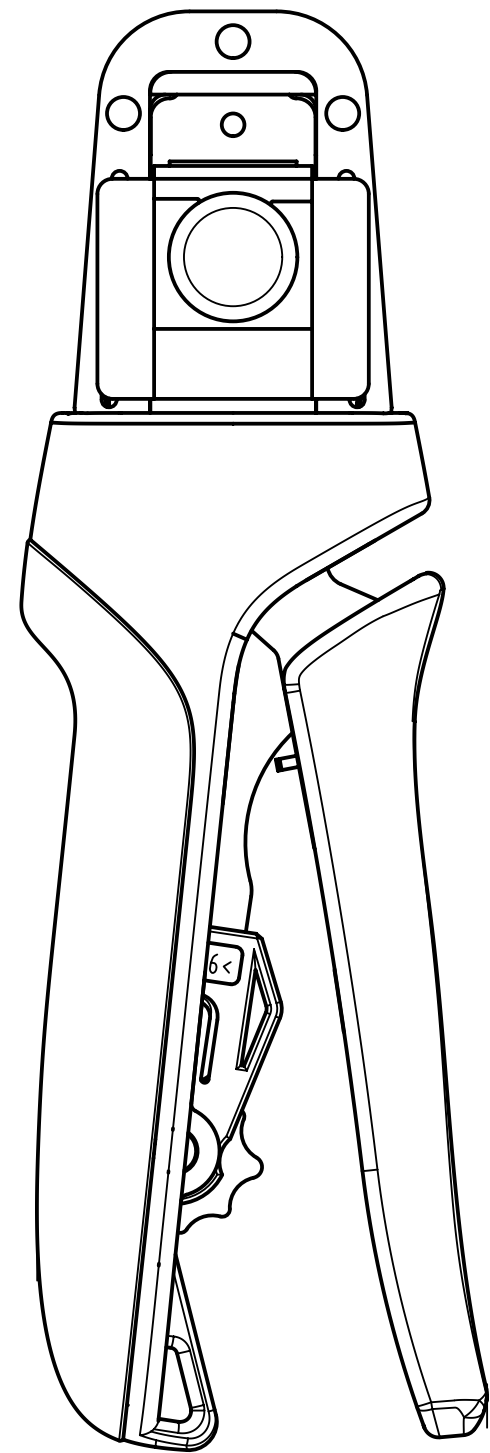

190

Positionierer FC2-3 im Set enthalten.
Ersatzteil-Nr. 09 99 000 0642

Locator FC2-3 scope of delivery.
Spare part no. 09 99 000 0642

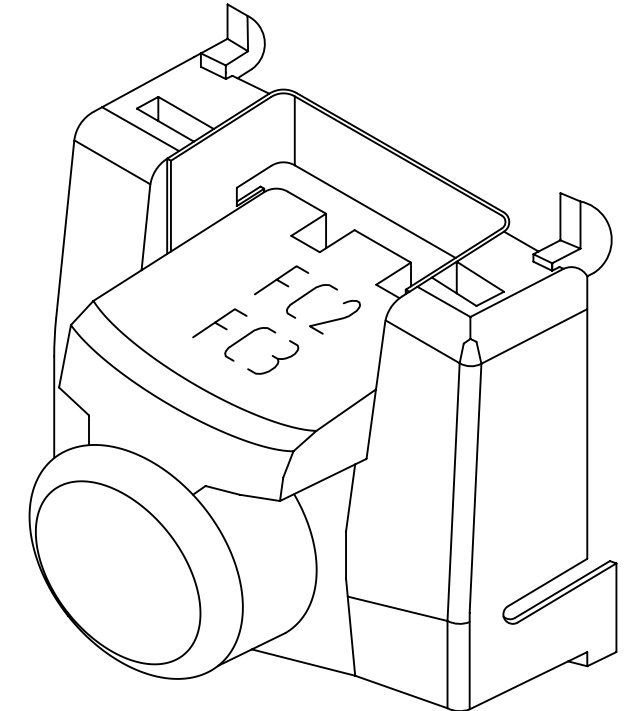

Anwendungsbereich: FC3 Kontakte
Application range: FC3 contacts
Leiterquerschnitt: Profil 1: 0,50-1,30 mm² (AWG 16-20)
wire gauge : Profil 2: 1,00-1,50 mm² (AWG 16)

Linearer Hub
Straight action principle

Entriegelbare Zwangssperre
Ratchet release

Kontaktpositionierung mit Positionierer
Contact positioning with locator

Präzise geschliffene Profile
Precisely ground profiles

Gewicht ca. 350 g
Weight approx. 350 g

für Crimpkontakte:
for crimp contacts:

09 06 000 8482	Feder / female	2	0,5-1,5	20-16	1,6-2,8
09 06 000 8472	Feder / female	1	0,5-1,5	20-16	1,6-2,8
Kontakt Nr. contact no.	Messer / Feder male / female	AFS PL	Leiterquerschnitt wire gauge	AWG AWG	Isolationsø Insulationø

	All rights reserved	Scale 1:1	Free size tol.	Ref.	
	Department EC PD - DE	Created by WAERMKER	Inspected by HAERTLING	Date 2012-10-08	State Final Release
HARTING Electronics GmbH D-32339 Espelkamp		Title CRIMP-TOOL FC 3			Doc-Key / ECH-Nr. 100073564/UGD/001/B
Type TB	Number 09990000077	Rev. B	Page 1/1		