



Chipsmall Limited consists of a professional team with an average of over 10 year of expertise in the distribution of electronic components. Based in Hongkong, we have already established firm and mutual-benefit business relationships with customers from,Europe,America and south Asia,supplying obsolete and hard-to-find components to meet their specific needs.

With the principle of “Quality Parts,Customers Priority,Honest Operation,and Considerate Service”,our business mainly focus on the distribution of electronic components. Line cards we deal with include Microchip,ALPS,ROHM,Xilinx,Pulse,ON,Everlight and Freescale. Main products comprise IC,Modules,Potentiometer,IC Socket,Relay,Connector.Our parts cover such applications as commercial,industrial, and automotives areas.

We are looking forward to setting up business relationship with you and hope to provide you with the best service and solution. Let us make a better world for our industry!



## Contact us

Tel: +86-755-8981 8866 Fax: +86-755-8427 6832

Email & Skype: info@chipsmall.com Web: www.chipsmall.com

Address: A1208, Overseas Decoration Building, #122 Zhenhua RD., Futian, Shenzhen, China



5 4 3 2 1

D  
C  
B  
A

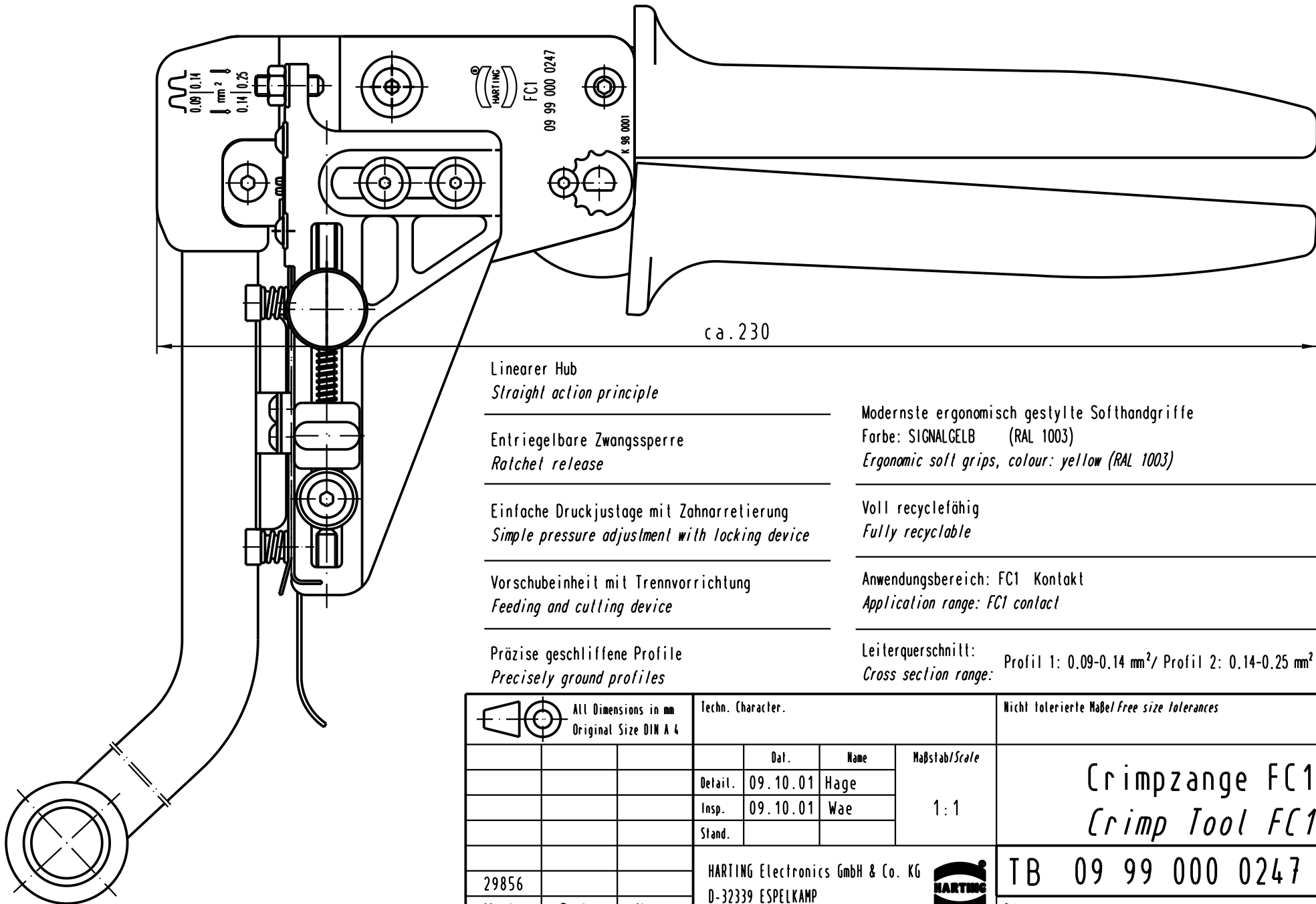

Linearer Hub  
*Straight action principle*

Entriegelbare Zwangssperre  
*Ratchet release*

Einfache Druckjustage mit Zahnarretierung  
*Simple pressure adjustment with locking device*

Vorschubeinheit mit Trennvorrichtung  
*Feeding and cutting device*

Präzise geschliffene Profile  
*Precisely ground profiles*

Modernste ergonomisch gestylte Softhandgriffe  
Farbe: SIGNALGELB (RAL 1003)  
*Ergonomic soft grips, colour: yellow (RAL 1003)*

Voll recyclefähig  
*Fully recyclable*

Anwendungsbereich: FC1 Kontakt  
*Application range: FC1 contact*

Leiterquerschnitt:  
*Cross section range:* Profil 1: 0.09-0.14 mm<sup>2</sup>/ Profil 2: 0.14-0.25 mm<sup>2</sup>



All Dimensions in mm  
Original Size DIN A 4

Techn. Character.

Nicht tolerierte Maß / Free size tolerances

	Dat.	Name	Maßstab/Scale 1:1
Detail.	09.10.01	Hage	
Insp.	09.10.01	Wae	
Stand.			

Crimpzange FC1  
*Crimp Tool FC1*

29856

HARTING Electronics GmbH & Co. KG  
D-32339 ESPELKAMP



TB 09 99 000 0247

Blatt / page

Mod. Dat. Name

Sub.