



Chipsmall Limited consists of a professional team with an average of over 10 year of expertise in the distribution of electronic components. Based in Hongkong, we have already established firm and mutual-benefit business relationships with customers from,Europe,America and south Asia,supplying obsolete and hard-to-find components to meet their specific needs.

With the principle of “Quality Parts,Customers Priority,Honest Operation,and Considerate Service”,our business mainly focus on the distribution of electronic components. Line cards we deal with include Microchip,ALPS,ROHM,Xilinx,Pulse,ON,Everlight and Freescale. Main products comprise IC,Modules,Potentiometer,IC Socket,Relay,Connector.Our parts cover such applications as commercial,industrial, and automotives areas.

We are looking forward to setting up business relationship with you and hope to provide you with the best service and solution. Let us make a better world for our industry!



Contact us

Tel: +86-755-8981 8866 Fax: +86-755-8427 6832

Email & Skype: info@chipsmall.com Web: www.chipsmall.com

Address: A1208, Overseas Decoration Building, #122 Zhenhua RD., Futian, Shenzhen, China



Technical Data Sheet

Rosenberger

RPC-2.40

Calibration Load
Jack

09K150-C10S3

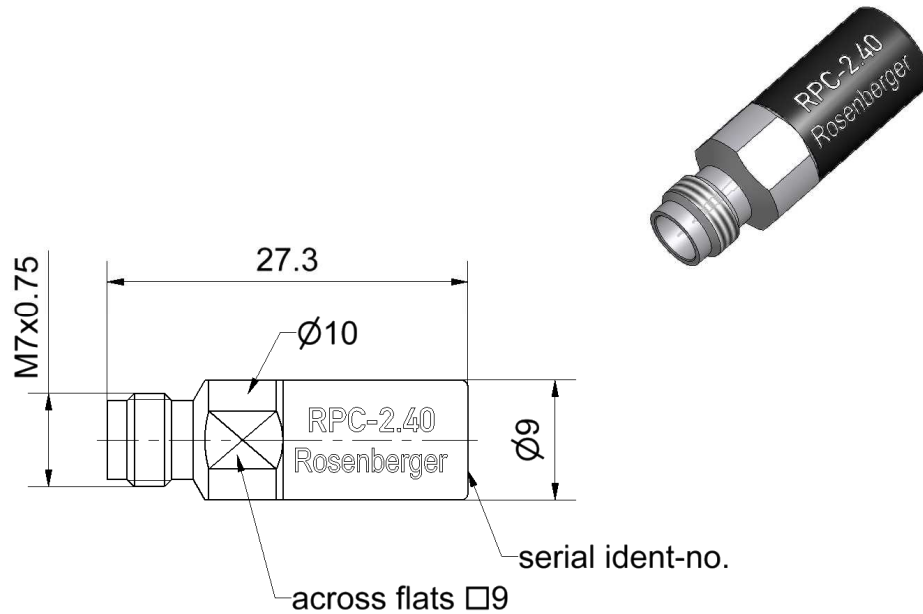

All dimensions are in mm; tolerances according to ISO 2768 m-H

Interface

According to
Mechanically compatible with

IEC 61169-40
RPC-1.85

Documents

Application note

AN001 "Calibration Services"

Material and plating

Connector parts

Center conductor
Outer conductor
Dielectric
Substrate

Material

CuBe
Stainless steel
PS
Al₂O₃

Plating

Gold, min. 1.27 µm, over nickel
Passivated

RPC-2.40

Calibration Load
Jack

09K150-C10S3

Electrical data

Frequency range	DC to 50 GHz
Return loss	≥ 36 dB, DC to 4 GHz ≥ 30 dB, 4 GHz to 26.5 GHz ≥ 22 dB, 26.5 GHz to 50 GHz
DC Resistance	50 Ω ± 0.25 Ω
Power handling	≤ 0.5 W

Mechanical data

Mating cycles	≥ 500
Maximum torque	1.65 Nm
Recommended torque	0.90 Nm
Gauge	0.00 mm to 0.03 mm

General standard definitions

For proper operation the vector network analyzer (VNA) needs a model describing the electrical behaviour of this calibration standard. The different models, units, and terms used will depend on the VNA type and they will have to be entered into the VNA. All values are based on typical geometry and plating.

Offset Z_0 / Impedance / Z_0	50 Ω
Offset Delay	0.0000 ps
Length (electrical) / Offset Length	0.000 mm
Offset Loss	0.00 GΩ/s
Loss	0.0000 dB/√GHz

Environmental data

Operating temperature range ¹	+20 °C to +26 °C
Rated temperature range of use ²	0 °C to +50 °C
Storage temperature range	- 40 °C to +85 °C

RoHS compliant

¹ Temperature range over which these specification are valid.

² This range is underneath and above the operating temperature range, within the calibration load is fully functional and could be used without damage.

Technical Data Sheet

Rosenberger

RPC-2.40 Calibration Load
Jack

09K150-C10S3

Declaration of calibration options

Factory Calibration

Standard delivery for this calibration standard includes a Factory Calibration. The Calibration Certificate issued reports individual calibration results, traceable to national / international standards. Model based standard definitions are reported in an Agilent/Keysight, Rohde & Schwarz and Anritsu compatible VNA format.

Accredited Calibration

Not available.

For further, more detailed information see application note AN001 on the Rosenberger homepage.

Calibration interval

Recommendation 12 months

Packing

Standard 1 pce in box
Weight 7.6 g/pce

Dieses Dokument ist urheberrechtlich geschützt • This document is protected by copyright • Rosenberger Hochfrequenztechnik GmbH & Co. KG

RF_35/09.14/6.2

Draft	Date	Approved	Date	Rev.	Engineering change number	Name	Date
Kerstin Herzog	26.09.05	Markus Müller	12.09.16	e00	16-1390	Marion Striegler	12.09.16

Rosenberger Hochfrequenztechnik GmbH & Co. KG P.O.Box 1260 D-84526 Tittmoning Germany www.rosenberger.de	Tel. : +49 8684 18-0 Email : info@rosenberger.de	Page 3 / 3
--	--	---------------