



Chipsmall Limited consists of a professional team with an average of over 10 year of expertise in the distribution of electronic components. Based in Hongkong, we have already established firm and mutual-benefit business relationships with customers from,Europe,America and south Asia,supplying obsolete and hard-to-find components to meet their specific needs.

With the principle of "Quality Parts,Customers Priority,Honest Operation,and Considerate Service",our business mainly focus on the distribution of electronic components. Line cards we deal with include Microchip,ALPS,ROHM,Xilinx,Pulse,ON,Everlight and Freescale. Main products comprise IC,Modules,Potentiometer,IC Socket,Relay,Connector.Our parts cover such applications as commercial,industrial, and automotives areas.

We are looking forward to setting up business relationship with you and hope to provide you with the best service and solution. Let us make a better world for our industry!



Contact us

Tel: +86-755-8981 8866 Fax: +86-755-8427 6832

Email & Skype: info@chipsmall.com Web: www.chipsmall.com

Address: A1208, Overseas Decoration Building, #122 Zhenhua RD., Futian, Shenzhen, China



4

3

2

1

THIS DRAWING IS UNPUBLISHED. RELEASED FOR PUBLICATION
 COPYRIGHT BY TYCO ELECTRONICS CORPORATION. ALL RIGHTS RESERVED.

LOC		DIST		REVISIONS					
U		-		P	LTR	DESCRIPTION	DATE	DWN	APVD
					0	REDRAWN, WAS UTILUX 01.03579.02	10-OCT-06	HT	WR

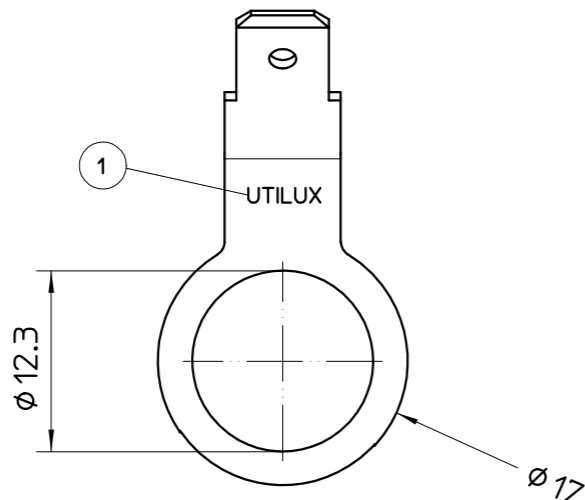
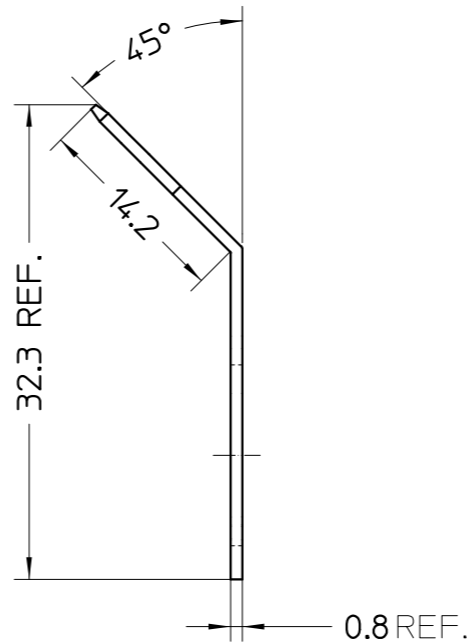
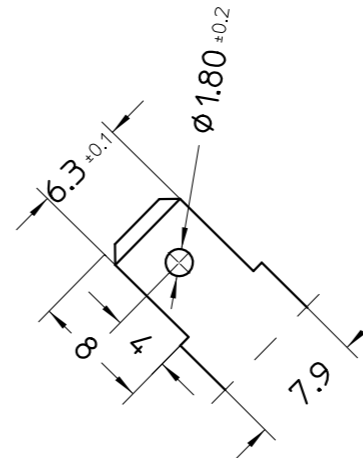
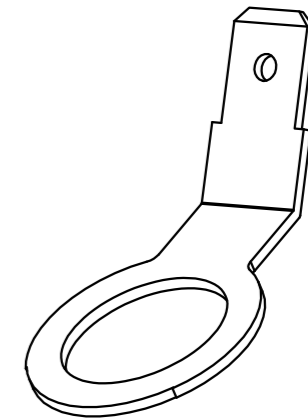

NOTES:
 1. UTILUX OR AMP LOGO STAMPED AS REQUIRED.

THIS INFORMATION IS CONFIDENTIAL AND PROPRIETARY TO TYCO ELECTRONICS CORPORATION AND ITS WORLDWIDE SUBSIDIARIES AND AFFILIATES. IT MAY NOT BE DISCLOSED TO ANYONE OTHER THAN TYCO ELECTRONICS PERSONNEL WITHOUT WRITTEN AUTHORIZATION FROM TYCO ELECTRONICS CORPORATION, HARRISBURG, PENNSYLVANIA, USA.

THIS DRAWING IS A CONTROLLED DOCUMENT.

ALL DIMENSIONS IN mm:	TOLERANCES UNLESS OTHERWISE SPECIFIED: DIMENSION (mm) TOLERANCE (+mm) LESS THAN 10 0.4 OVER 10 TO 30 0.5 OVER 30 TO 80 0.7 OVER 80 TO 250 1.0 ANGLES ±2°

MATERIAL REF. BLOCK
 FINISH REF. BLOCK

BRASS, PRE-TIN	TAB QC. 6.3 (H3579)	1-1627156-0
MATERIAL	DESCRIPTION (UTILUX P/N)	PART No.
DWN: H.THA1 10.10.06 CHK: W.RIEDE 10.10.06 APVD: W.RIEDE 10.10.06 PRODUCT SPEC: - APPLICATION SPEC: - WEIGHT: -		tyco Tyco Electronics Corporation Electronics AUSTRALIA NAME: TAB, QC 6.3
SIZE	CAGE CODE	DRAWING NO
A3		©=1627156
CUSTOMER DRAWING		RESTRICTED TO -
SCALE	SHEET	OF
2:1	1	1
REV	0	