



Chipsmall Limited consists of a professional team with an average of over 10 year of expertise in the distribution of electronic components. Based in Hongkong, we have already established firm and mutual-benefit business relationships with customers from,Europe,America and south Asia,supplying obsolete and hard-to-find components to meet their specific needs.

With the principle of “Quality Parts,Customers Priority,Honest Operation,and Considerate Service”,our business mainly focus on the distribution of electronic components. Line cards we deal with include Microchip,ALPS,ROHM,Xilinx,Pulse,ON,Everlight and Freescale. Main products comprise IC,Modules,Potentiometer,IC Socket,Relay,Connector.Our parts cover such applications as commercial,industrial, and automotives areas.

We are looking forward to setting up business relationship with you and hope to provide you with the best service and solution. Let us make a better world for our industry!



Contact us

Tel: +86-755-8981 8866 Fax: +86-755-8427 6832

Email & Skype: info@chipsmall.com Web: www.chipsmall.com

Address: A1208, Overseas Decoration Building, #122 Zhenhua RD., Futian, Shenzhen, China



THIS DRAWING IS UNPUBLISHED. RELEASED FOR PUBLICATION
 © COPYRIGHT copyright_date BY - ALL RIGHTS RESERVED.

REVISIONS				
P	LTR	DESCRIPTION	DATE	DWN APVD
	B	INITIAL RELEASE	02AUG2013	MKD RRP

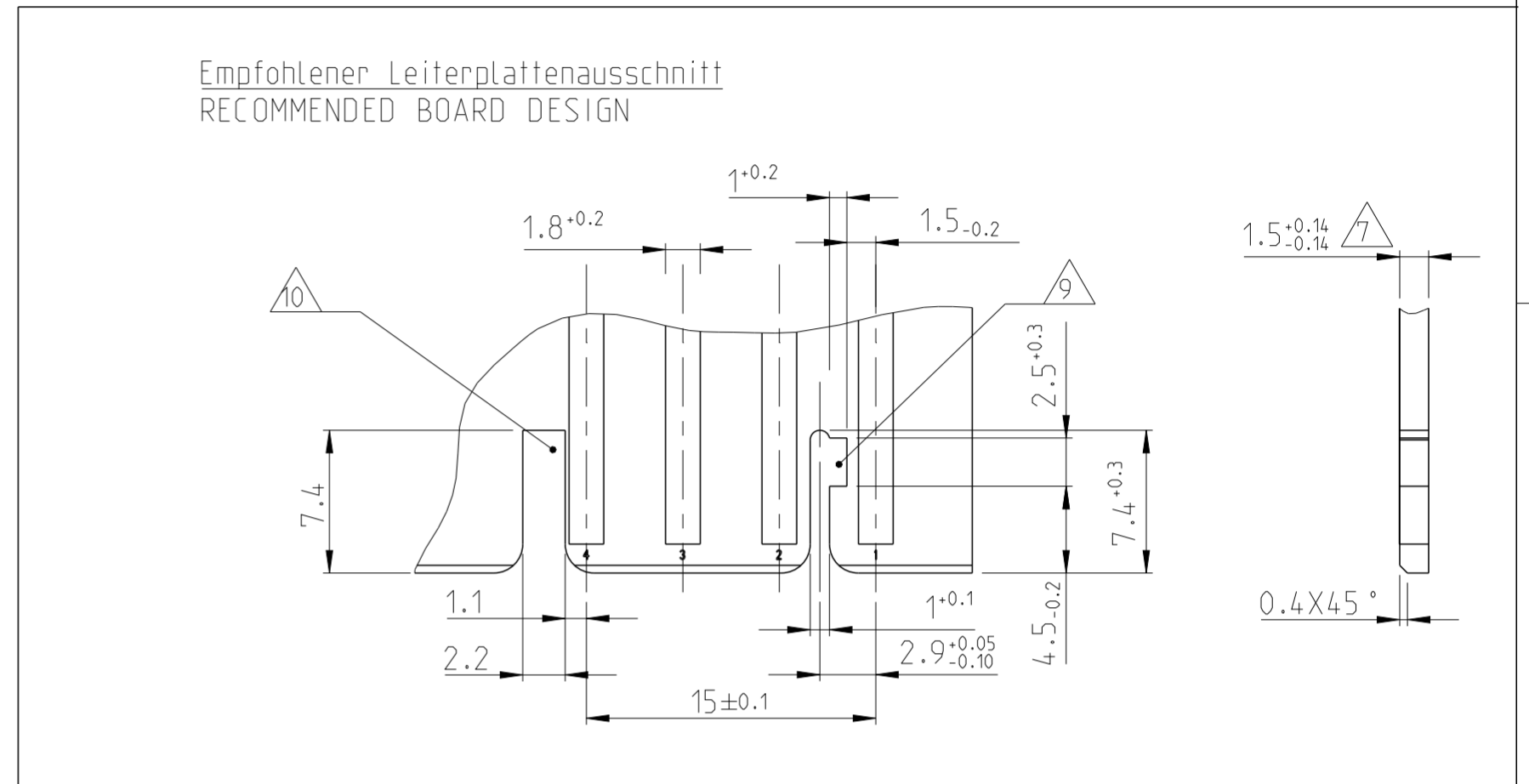
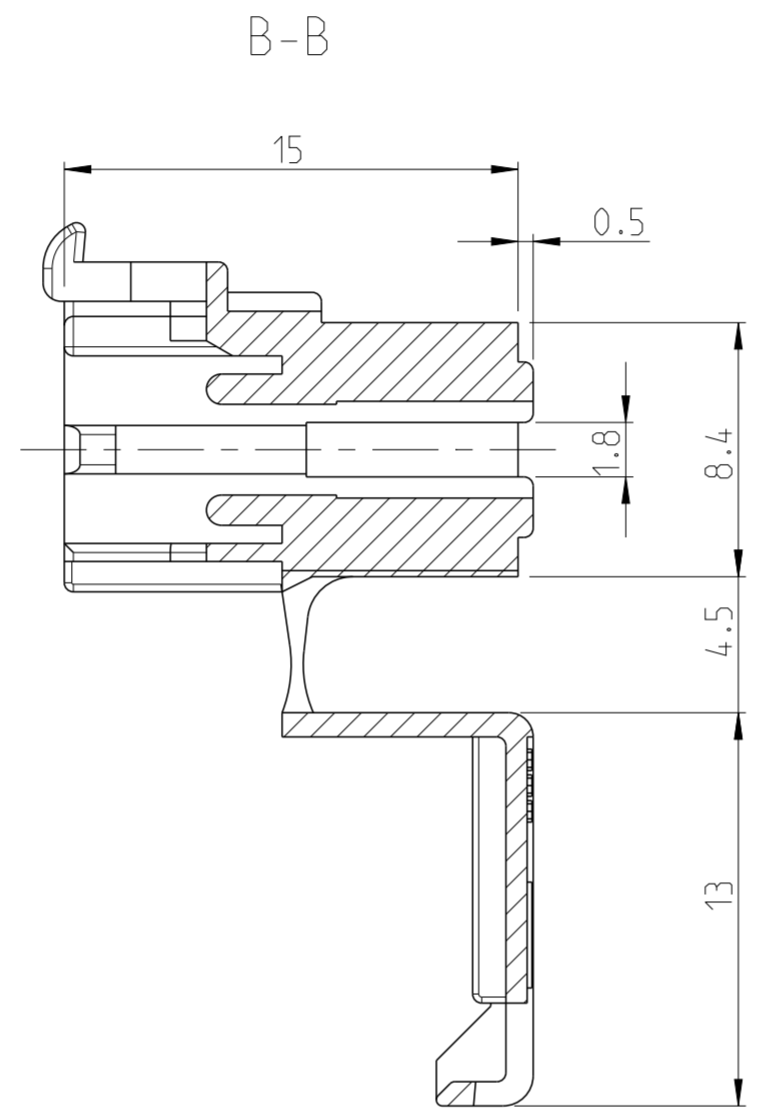
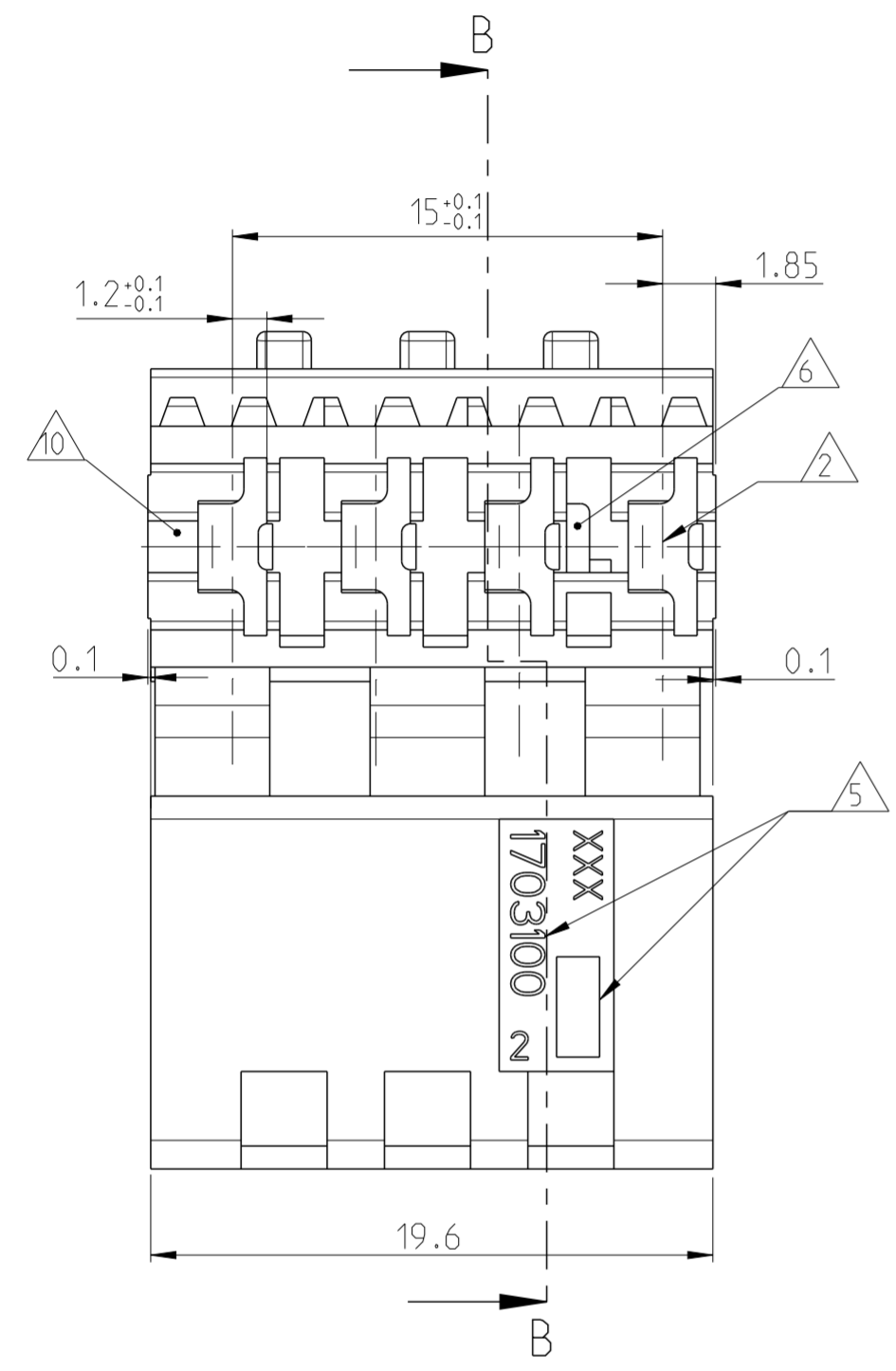

- Bemerkungen**
NOTES
- 1 Massgebend ist der deutsche Text
ONLY THE GERMAN-LANGUAGE VERSION SHALL BE BINDING
 - 2 Lage des Kontaktpunktes auf der Leiterplatte; Abweichung ±0.4
POSITION OF CONTACT POINT ON BOARD; DEVIATION ±0.4
 - 3 Kontaktierung zur Drahtmitte um 0.7mm versetzt
CONTACTING 0.7mm DISPLACED TO WIRE CENTRELINE
 - 4 Kontaktkammer-Nr.
CONTACT CAVITY #
 - 5 Firmenlogo und Leergehäuse-Nr.
ARTWORK LOGO AND HOUSING # (NON LOADED)
 - 6 Kodersteg zwischen Kammer Nr.1&2
KEYING RIB BETWEEN CAVITY Nr. 1 & 2
 - 7 Ausführung nach DIN 60249-2-4
BOARD DESIGN ACCORDING TO DIN 60249-2-4
 - 8 Crimp Kontakt-Nr.:
Material: CuSn4 926770-1, 926917-1
CRIMP CONTACT #: MATERIAL: CuSn4
 - 9 SQUARE HOLE 2X2 mm OPTIONAL LOCKING HOLE Ø2.5 mm
 - 10 Kodersteg Nach Letzter Kammer
KEYING RIB AFTER LAST CAVITY
 - 11 MATERIAL ACCORDING TO IEC 60335-1 (INCLUDING GWT 750 ° C NO FLAME)

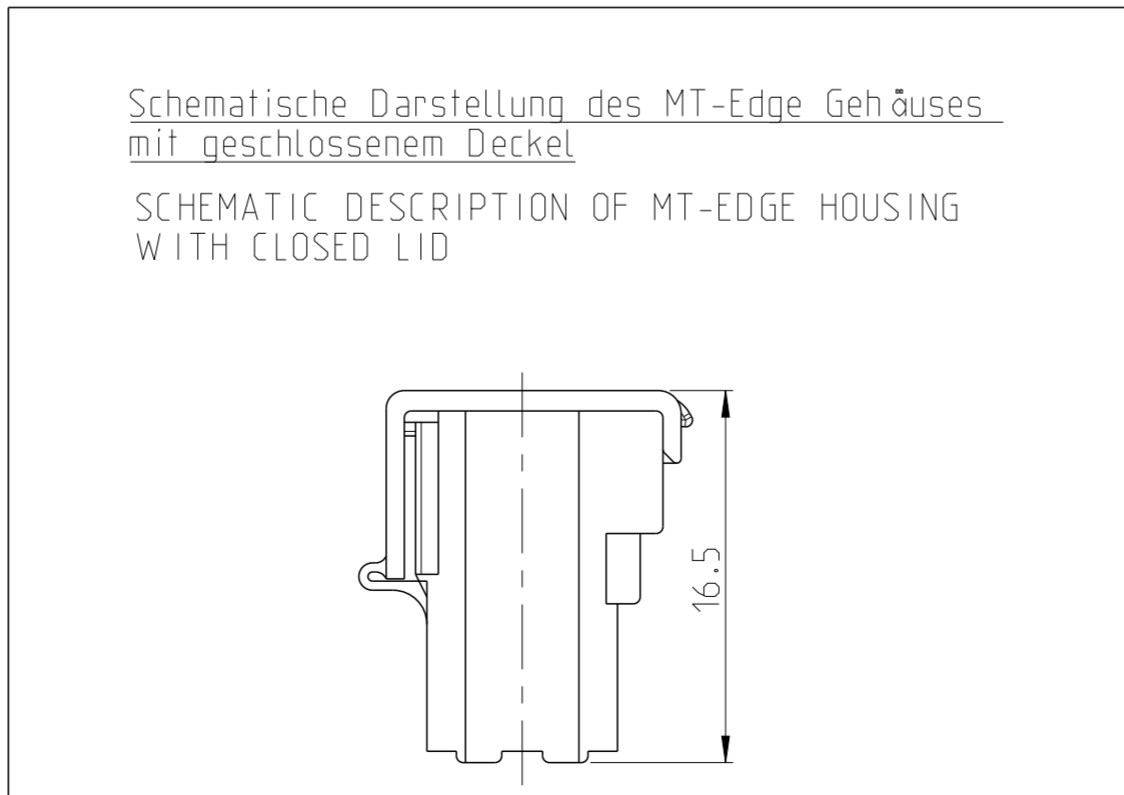
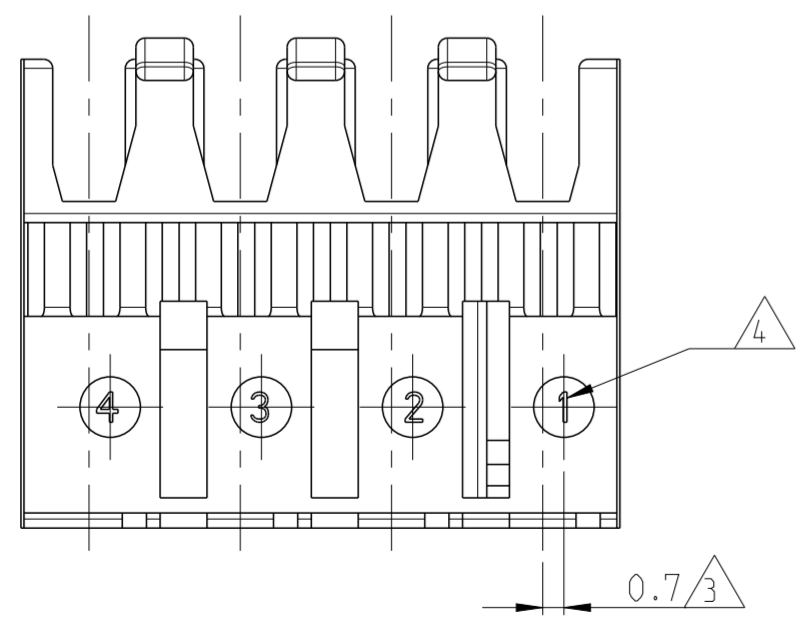

1-1703100-1	11	MT-EDGE HOUSING	NATURE
PART-NO.:		DESCRIPTION	COLOUR

THIS DRAWING IS A CONTROLLED DOCUMENT.		DWN DHANESH 02AUG2013	STE TE Connectivity	
DIMENSIONS: mm		CHK DHANESH 02AUG2013		
TOLERANCES UNLESS OTHERWISE SPECIFIED:		APVD Rajendra 02AUG2013	NAME 4-WAYS MT-EDGE - HOUSING LOOSE PIECE VERSION	
0 PLC ±	±0.2	PRODUCT SPEC 108-18003	SIZE CAGE CODE DRAWING NO RESTRICTED TO	
1 PLC ±		APPLICATION SPEC 114-18002	A2 00779 C-1703100	
2 PLC ±		WEIGHT -	SCALE 3:1 SHEET 1 OF 1 REV B	
3 PLC ±		MATERIAL 11 PA6/UL94V-2	CUSTOMER DRAWING	
4 PLC ±				
ANGLES ±				
FINISH ±				