



Chipsmall Limited consists of a professional team with an average of over 10 year of expertise in the distribution of electronic components. Based in Hongkong, we have already established firm and mutual-benefit business relationships with customers from,Europe,America and south Asia,supplying obsolete and hard-to-find components to meet their specific needs.

With the principle of “Quality Parts,Customers Priority,Honest Operation,and Considerate Service”,our business mainly focus on the distribution of electronic components. Line cards we deal with include Microchip,ALPS,ROHM,Xilinx,Pulse,ON,Everlight and Freescale. Main products comprise IC,Modules,Potentiometer,IC Socket,Relay,Connector.Our parts cover such applications as commercial,industrial, and automotives areas.

We are looking forward to setting up business relationship with you and hope to provide you with the best service and solution. Let us make a better world for our industry!



Contact us

Tel: +86-755-8981 8866 Fax: +86-755-8427 6832

Email & Skype: info@chipsmall.com Web: www.chipsmall.com

Address: A1208, Overseas Decoration Building, #122 Zhenhua RD., Futian, Shenzhen, China



THIS DRAWING IS UNPUBLISHED.

RELEASED FOR PUBLICATION

ALL RIGHTS RESERVED.

© COPYRIGHT -

LOC
DW

DIST
-

REVISIONS

P	LTR	DESCRIPTION	DATE	DWN	APVD
		SEE SHEET 1.			

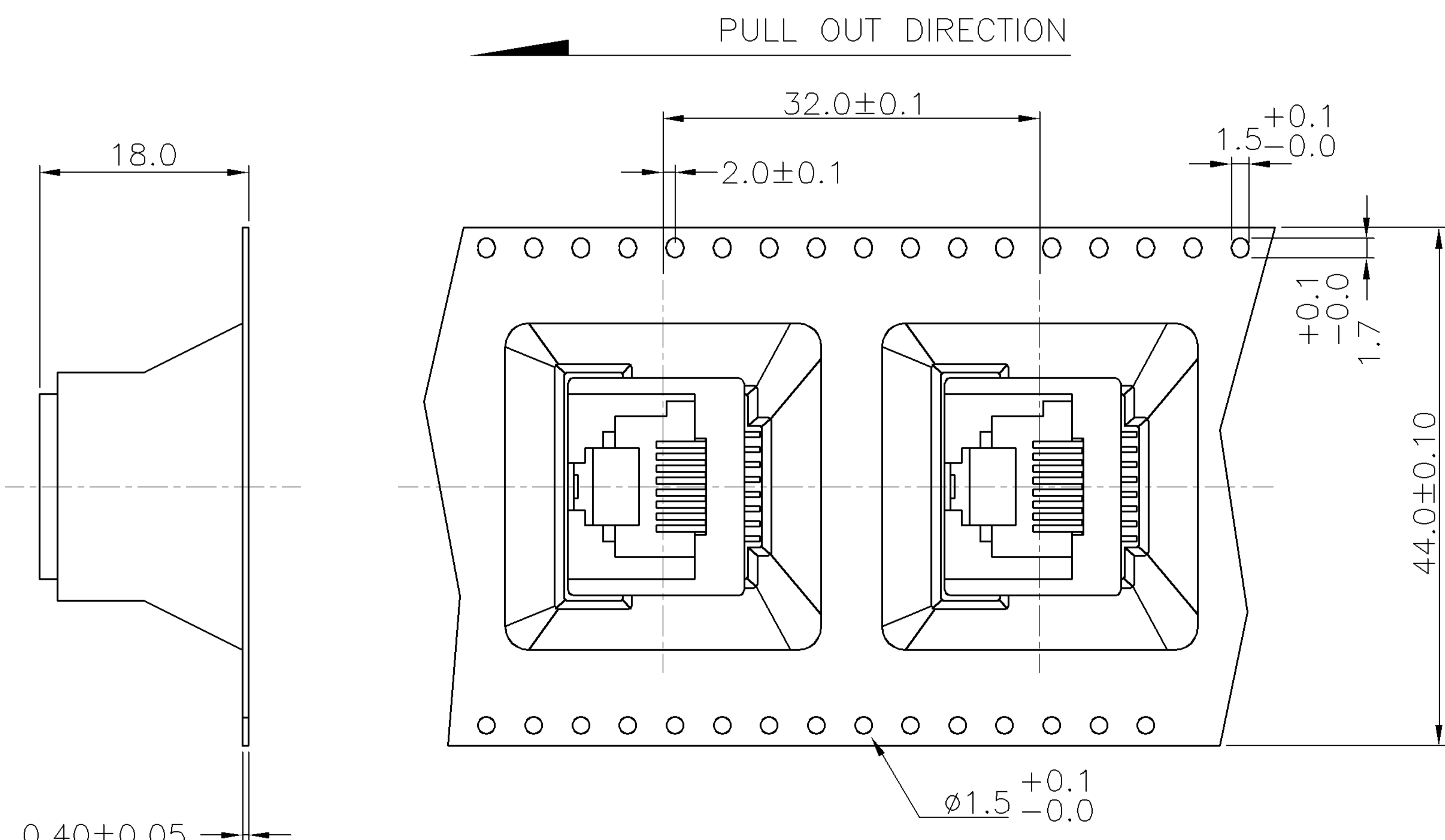
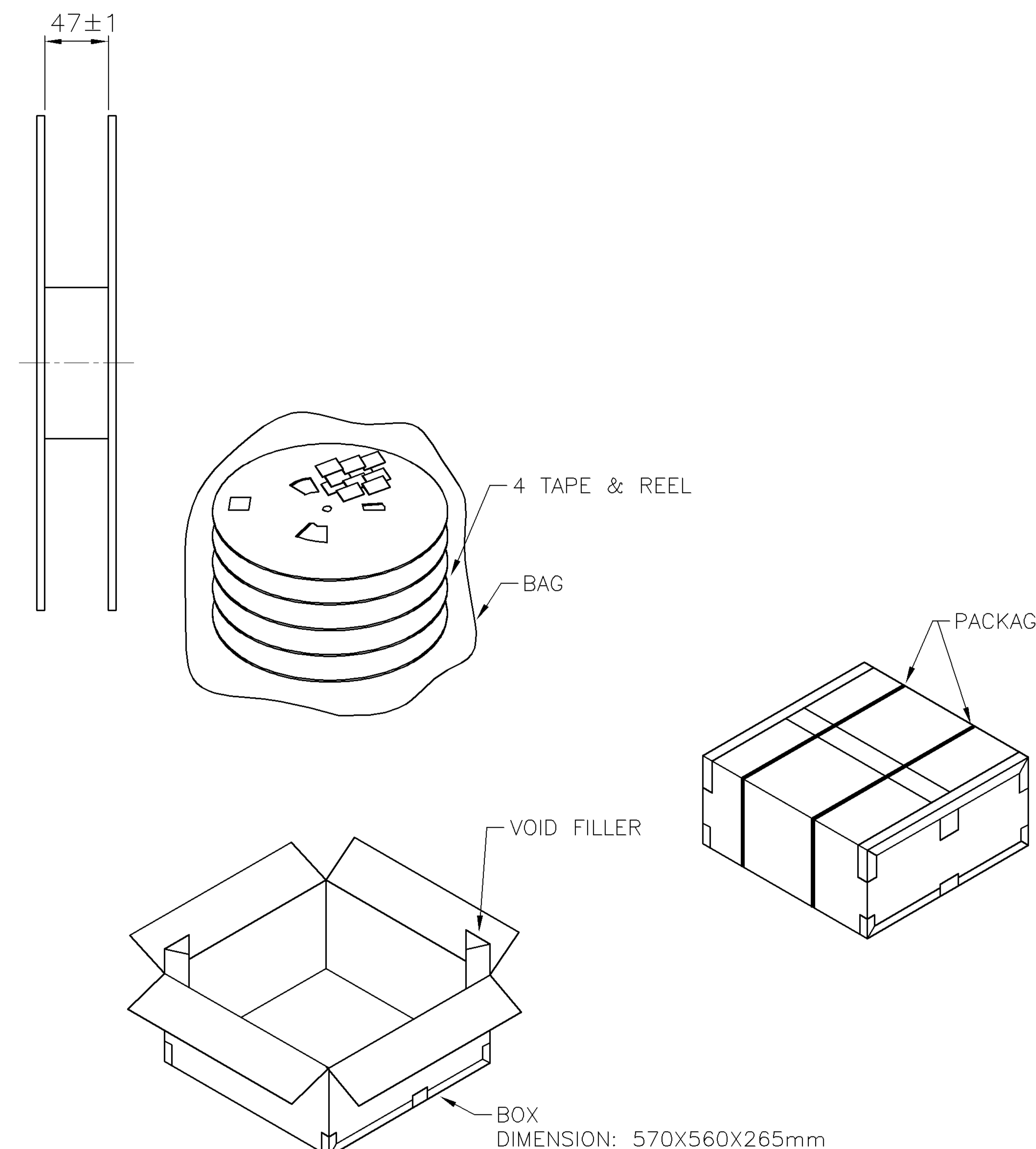
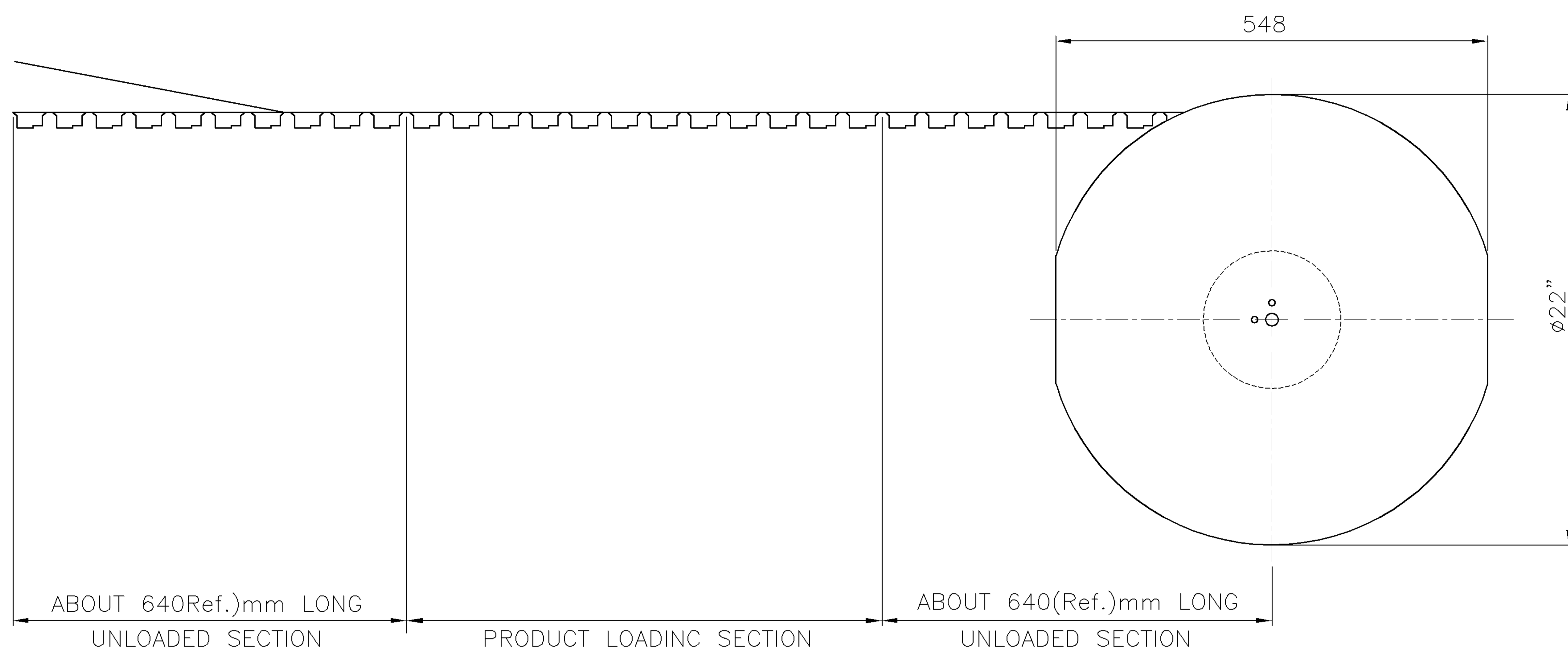

1400	350	8P8C	2-1734858-X
1400	350	6P6C	1-1734858-X
1400	350	4P4C	1734858-X
TOTAL(PCS)	PCS/ REEL	RJ45/RJ11	PART NUMBER

* COVER TAPE PEELING FORCE:

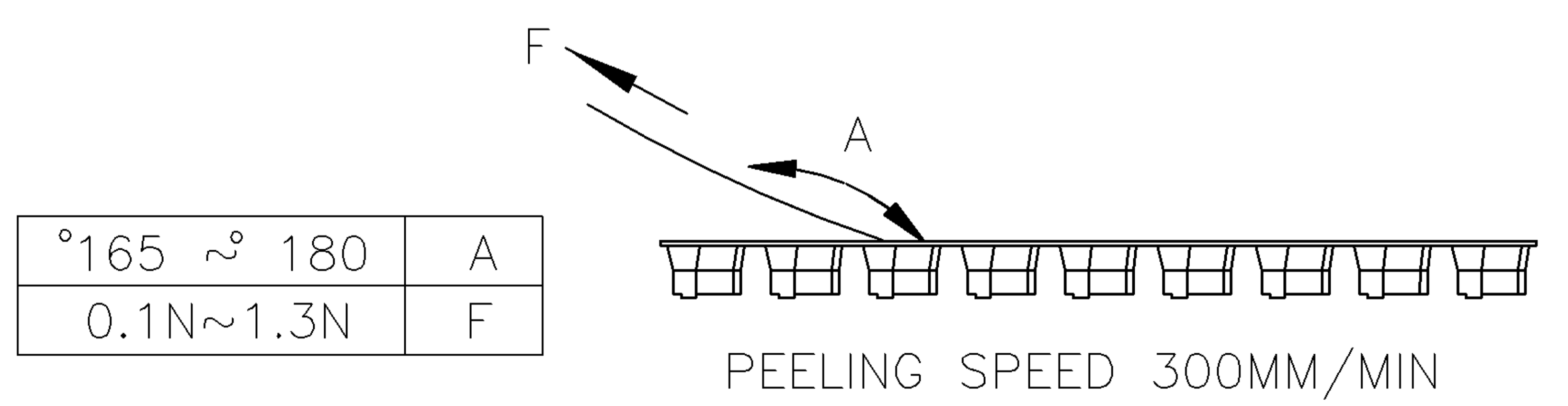

THIS DRAWING IS A CONTROLLED DOCUMENT.		DWN O. HOU 06NOV2007	 TE Connectivity NAME MODULAR JACK, RJ45/RJ11 TOP ENTRY, SMT TYPE		
DIMENSIONS: MM		CHK S. HOU 06NOV2007			PRODUCT SPEC
TOLERANCES UNLESS OTHERWISE SPECIFIED:		APVD W. KODAMA 06NOV2007			APPLICATION SPEC
MATERIAL		WEIGHT			RESTRICTED TO
0 PLC ± - 1 PLC ± - 2 PLC ± - 3 PLC ± - 4 PLC ± - ANGLES ± - FINISH ± -		SIZE A3	CAGE CODE 00779	DRAWING NO C=1734858	
CUSTOMER DRAWING			SCALE	SHEET 3 OF 3	
			REV	A2	