



Chipsmall Limited consists of a professional team with an average of over 10 year of expertise in the distribution of electronic components. Based in Hongkong, we have already established firm and mutual-benefit business relationships with customers from,Europe,America and south Asia,supplying obsolete and hard-to-find components to meet their specific needs.

With the principle of “Quality Parts,Customers Priority,Honest Operation,and Considerate Service”,our business mainly focus on the distribution of electronic components. Line cards we deal with include Microchip,ALPS,ROHM,Xilinx,Pulse,ON,Everlight and Freescale. Main products comprise IC,Modules,Potentiometer,IC Socket,Relay,Connector.Our parts cover such applications as commercial,industrial, and automotives areas.

We are looking forward to setting up business relationship with you and hope to provide you with the best service and solution. Let us make a better world for our industry!



Contact us

Tel: +86-755-8981 8866 Fax: +86-755-8427 6832

Email & Skype: info@chipsmall.com Web: www.chipsmall.com

Address: A1208, Overseas Decoration Building, #122 Zhenhua RD., Futian, Shenzhen, China



THIS DRAWING IS UNPUBLISHED.

RELEASED FOR PUBLICATION

20

© COPYRIGHT 20 BY -

ALL RIGHTS RESERVED.

REVISIONS

P	LTR	DESCRIPTION	DATE	DWN	APVD
	B4	REVISED PER ECR-18-005844	17APR2018	RS	DS

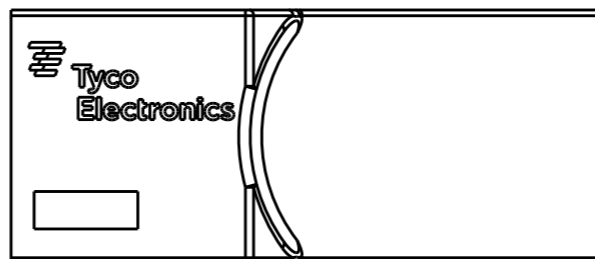

- ① 66 NYLON, V0, NO DRIP
- ② 6/6 NYLON, V2

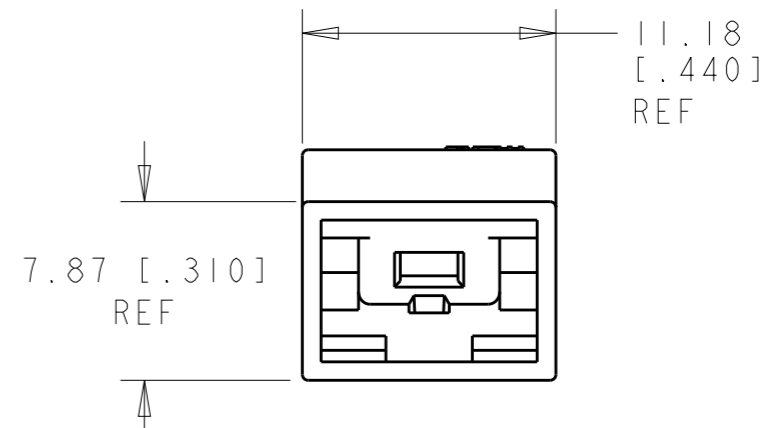
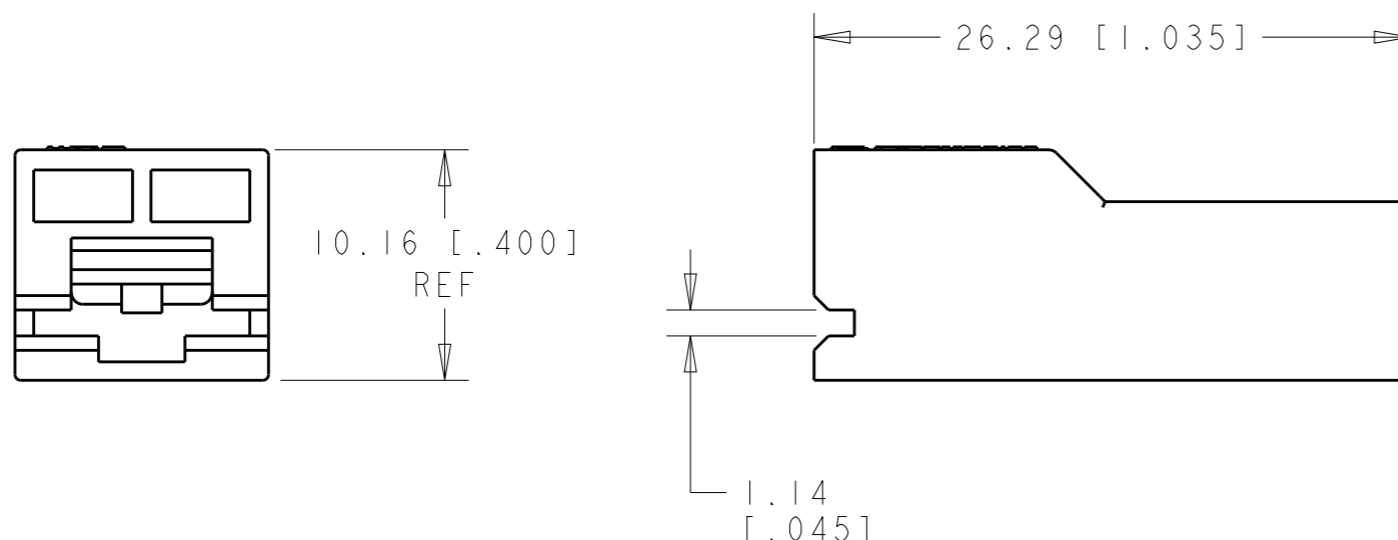

FROSTED SURFACE

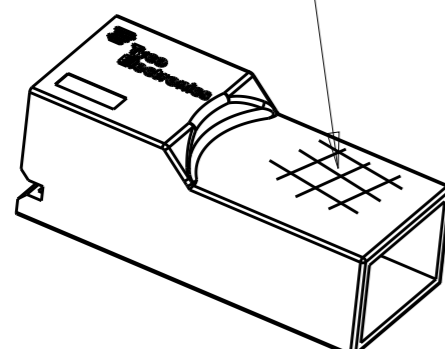

SCALE 2:1

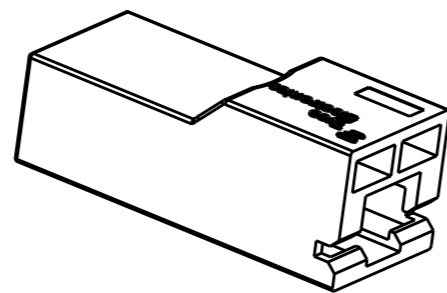

SCALE 2:1

BLACK	66 Nylon V0 Natural	1-1969186-1
NATURAL	②	1969186-2
BLACK	①	1969186-1
COLOR	MATERIAL	PART NO.

THIS DRAWING IS A CONTROLLED DOCUMENT.		DWN JR RUTH 23JAN2008	 TE Connectivity		
DIMENSIONS: mm [INCHES]		CHK PETE DESANTIS 23JAN2008			
TOLERANCES UNLESS OTHERWISE SPECIFIED:		APVD PETE DESANTIS 23JAN2008	NAME HOUSING, RECEPTACLE, FASTON, 7.92 [.312] SERIES		
0 PLC ±- 1 PLC ±- 2 PLC ±0.25 [.010] 3 PLC ±- 4 PLC ±- ANGLES ±-		PRODUCT SPEC -	RESTRICTED TO		
MATERIAL SEE TABLE material_2		APPLICATION SPEC -	SIZE A3	CAGE CODE 00779	DRAWING NO C-1969186
FINISH SEE TABLE finish_spec_2		WEIGHT -	SCALE 3:1		
		CUSTOMER DRAWING	SHEET 1 OF 1		
			REV B4		